

# Measuring Tools

---



**D01-D40**

# INDEX

D01~14

## Measuring Fixture / Pin & Block Gauges



55000 D01



55004 D01



55006 D02



55008 D02



55010 D03



55015 D03



55020 D03



55030 D04



55042 D04



55050 D04



55055 D05



55062 D07



55070 D07



55080 D09



55090 D10



55100 D11



55110 D12



55120 D13



55130 D14

D15~30

## Edge Finder / Zero-setter / Dial indicators



55160 D15



55170 D16



55180 D17



55182 D18



55184 D19



55186 D20



55190 D21



55200 D21



55210 D22



55220 D23



55230 D24



55240 D24



55250 D25



55255 D26



55260 D27



55265 D28



55270 D29

**D31~50**
**Micrometers / Concentricity Measuring Instrument**

55280 D31



55282 D31



55290 D32



55295 D32



55302 D33



55305 D35



55312 D37



55335 D39



55345 D41



55348 D43



55350 D44



55355 D44



55400/05 D45



55410/15 D45



55430/35 D46



55440 D46



55441 D47



55442 D47



55443 D48



55445 D48



55446 D49



55448 D49



55450 D50



55460 D50

**D51~56**
**Tool Pre-setter / Fixture for CMM**

55480 D51



55485 D52



55490 D53



55495 D54



55600 D55



55610-01 D56



55610-02 D56

# Measuring Tool

**55000**

AP25/30/46

Adjustable Angle Plate

PAT: 192623  
ZL 02 2 42472.5



Application on milling .



Marking on workpiece

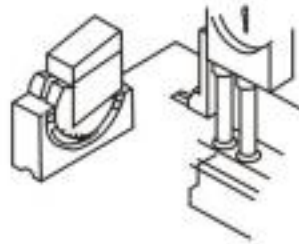

## Features :

- ▶ Made of tool steel with HRC52°~ 56°.
- ▶ Suitable for placing on large vise for angular processing needs.
- ▶ Adjustable angle 30°~ 0°~ 60°
- ▶ Squareness:0.005mm
- ▶ Parallelism:0.01mm

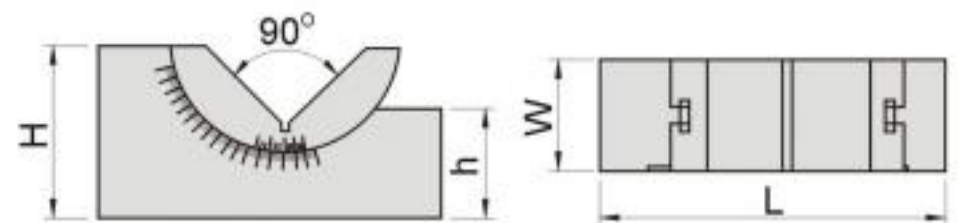

Unit:mm

Order No.	Model	L	W	H	h	N.W.
55000-25	AP25	75	25	37.3	25	0.4kg
55000-30	AP30	102	30	50.8	30	0.9kg
55000-46	AP46	102	46	50.8	30	1.4kg

**55004**

A2~6

B Type Vee Blocks



Sold in pairs

## Features :

- ▶ Made of tool steel with HRC56°~ 60°.
- ▶ V groove accuracy within 0.005mm, suitable for inspecting concentricity.

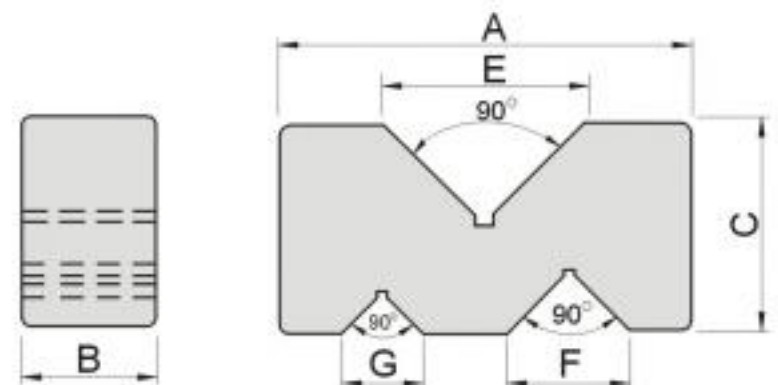

Unit:mm

Order No.	Model	A	B	C	E	F	G	N.W.
55004-02	A2	50	19	24	24	17	13	0.3kg
55004-03	A3	75	24	35	37	24	16	0.8kg
55004-04	A4	100	33	52	50	30	20	2.2kg
55004-05	A5	125	44	69	63	37	26	5.0kg
55004-06	A6	150	50	80	75	45	30	7.8kg

**55006** PV100 V Blocks with C Clamp



Sold in pairs

N.W. 2.8kg

**Features:**

- ▶ Made of tool steel with HRC56°~ 60°.
- ▶ Precisely ground and high accuracy of V groove.
- ▶ Suitable for processing steel rod or testing concentricity.
- ▶ Clamping range 3 ~ 20
- ▶ Height deviation  $\pm 0.003$ mm
- ▶ Squareness: 0.005mm
- ▶ V groove acc. within 0.005mm

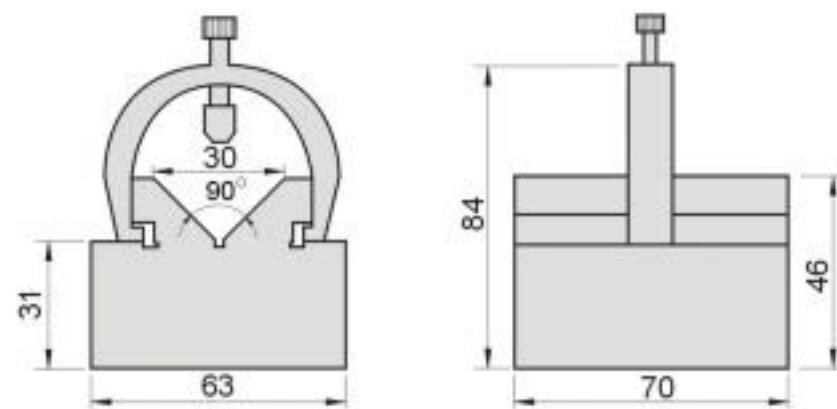

**55008** PV150/200 V Blocks with C Clamp



Sold in pairs

**Features:**

- ▶ Suitable for machining, EDM, testing purposes.
- ▶ Clamping range:  $\varnothing 3.5$ mm~  $\varnothing 33$ mm(PV150),  $\varnothing 3.5$ mm~  $\varnothing 41$ mm(PV200)
- ▶ V groove parallelism 0.005mm / 100mm
- ▶ Squareness within 0.005mm / 100mm
- ▶ Made of tool steel with HRC56°~ 60°.

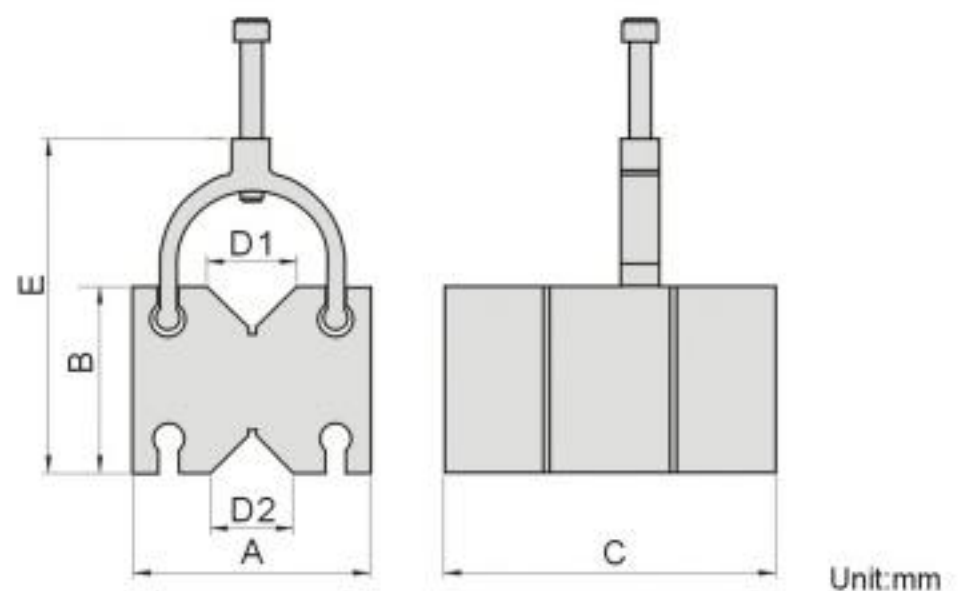

Unit:mm

Order No.	Model	A	B	C	D1	D2	E	N.W.
55008-01	PV150	64	45	70	29	24	90	1.3kg
55008-02	PV200	90	70	125	34	31	125.5	5.2kg

# Measuring Tool

**55010**

S100

Sine Bar



N.W. 0.8kg

## Features:

- ▶ Collocate with gauge blocks for measuring workpiece' angle.
- ▶ Parallelism within 0.003mm
- ▶ Biaxial accuracy  $\pm 0.003\text{mm}$
- ▶ Material: YK30 , HRC56°~ 60°

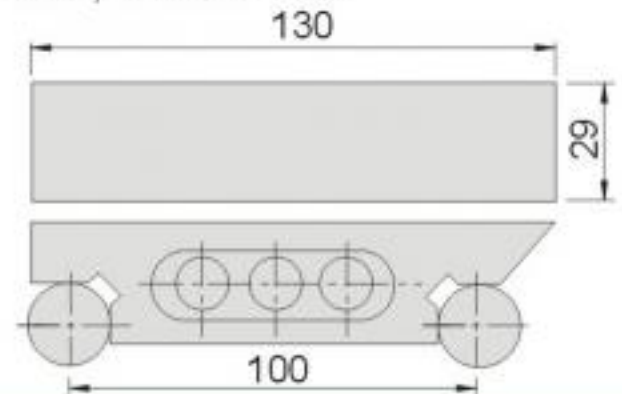

**55015**

SB

Magnetic Sine Bar



Magnetic base

N.W. 0.3kg

## Features:

- ▶ Collocate with gauge blocks for measuring workpiece' angle.
- ▶ Parallelism within 0.003mm
- ▶ Squareness within 0.005mm
- ▶ Biaxial accuracy  $\pm 0.003\text{mm}$
- ▶ Material: YK30 , HRC56°~ 60°

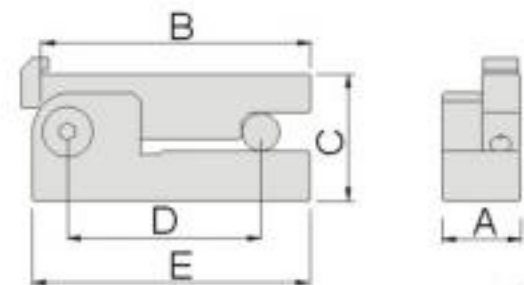

Unit:mm

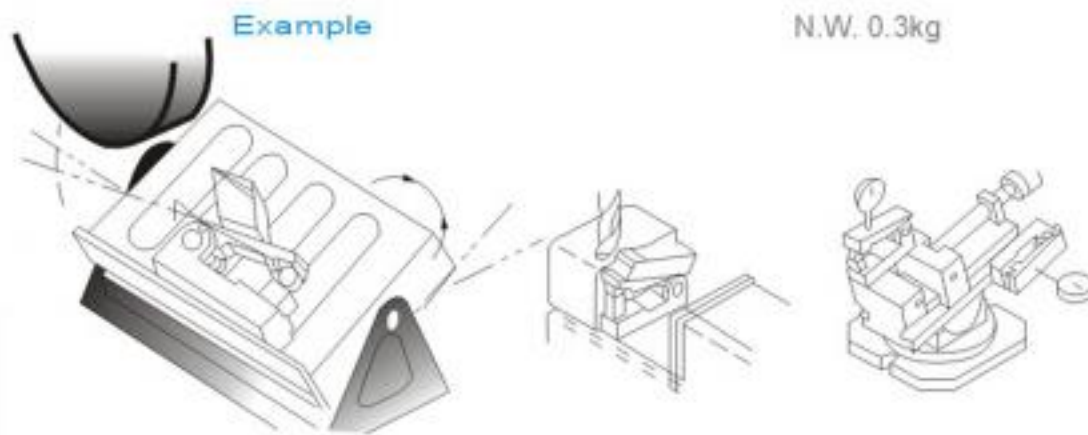

Order No.	Model	A	B	C	D	E	N.W.
55015-01	SB50	20	70	33	50	72	0.3kg
55015-02	SB100	28	120	36	100	122	0.7kg

**55020**

MSB100

Magnetic Sine Bar



Magnetic base

N.W. 2.0kg

## Features:

- ▶ Collocate with gauge blocks for measuring workpiece' angle.
- ▶ Angular deviation within 30 sec.
- ▶ Material: SKS , HRC56°~ 60°

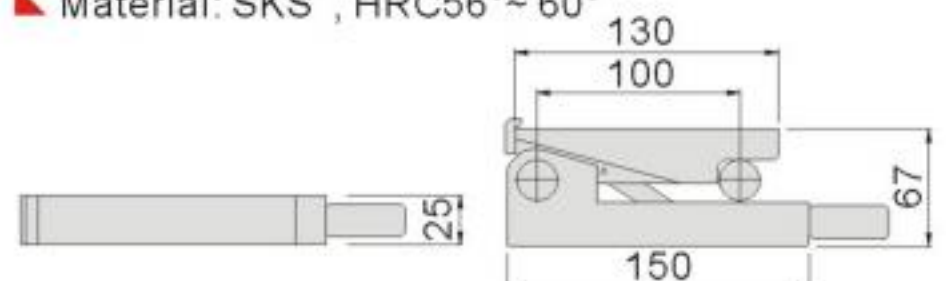

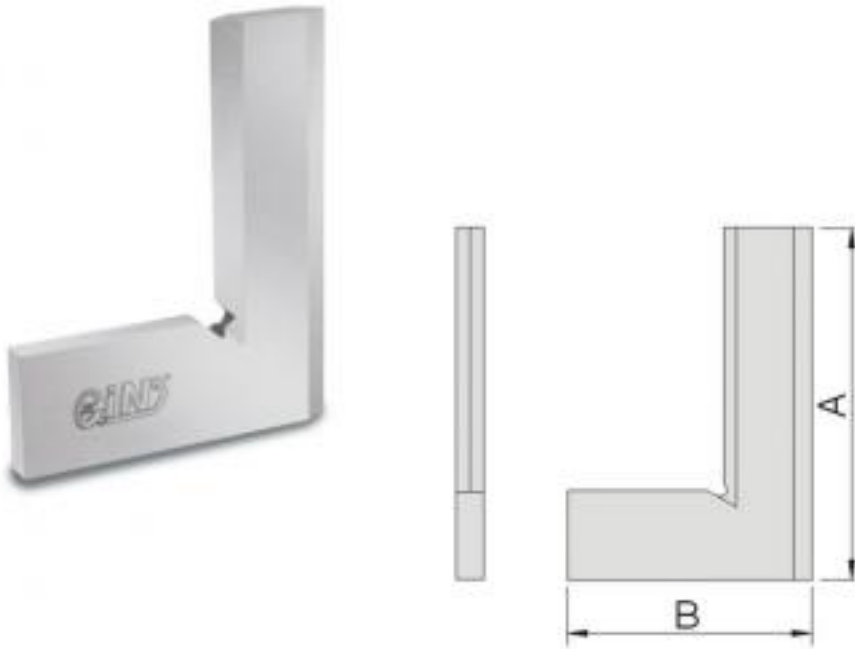
**55030**
**HT**
**Precision Knife Edge Square**

**Features :**

- ▶ Suitable in squareness and leveling inspection with precision inner and outer angle.
- ▶ Made of high quality stainless steel with precisely ground.
- ▶ Accuracy: DIN875/00

Unit:mm

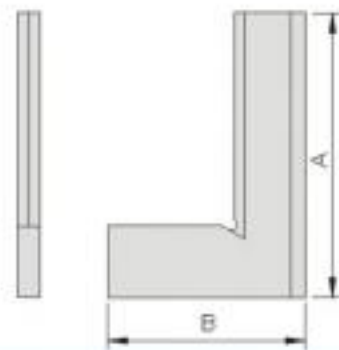
Order No.	Model	A	B	N.W.
55030-01	HT01	50	40	0.05kg
55030-02	HT02	75	50	0.10kg
55030-03	HT03	100	70	0.15kg
55030-04	HT04	150	100	0.40kg
55030-05	HT05	200	130	0.65kg

**55040**
**H**
**Precision Knife Edge Square**

**Features :**

- ▶ With precision inner and outer angle as well as precision ground.
- ▶ Matted chromed for better observation.
- ▶ Made of tool steel.
- ▶ Accuracy: DIN875/1

Unit:mm

Order No.	Model	A	B	N.W.
55040-04	H304	100	70	0.2kg
55040-06	H306	150	100	0.4kg
55040-08	H308	200	130	0.6kg
55040-10	H310	250	165	1.3kg
55040-12	H312	300	200	1.6kg

**55050**
**HP**
**Precision Straight Edges**

**Features :**

- ▶ Made of high quality stainless steel with precision ground.
- ▶ Accuracy: DIN874/0

Unit:mm

Order No.	Model	Spec.	N.W.
55050-01	HP050	50	0.06kg
55050-02	HP100	100	0.14kg
55050-03	HP150	150	0.22kg
55050-04	HP200	200	0.33kg
55050-05	HP300	300	0.45kg
55050-06	HP400	400	0.60kg
55050-07	HP500	500	0.75kg

# Measuring Tool

**55055**

A300-600

**Multi-function Angle Level**



A300



A500



A600

## Features :

- ▶ Compact design with micro ball bearing for quick measuring and resetting.
- ▶ Double pointers design can make calibration for each other and measure level and any bevel angle. Also for setting simulation level and measure angle and level difference.
- ▶ The transparent temperature-resistant oil may visually amplify the pointer for better optical reading.
- ▶ Ground magnetic railway on base of A300.
- ▶ Ground face with magnetic railway on base of A500 & A600.



Unit:mm

Order No.	Model	Dimension	Housing material	Accuracy	N.W.	Accessory
55055-02	A300	93x79x16	ABS	±0.1°	0.11kg	150mm Stainless Ruler
55055-03	A500	94x102x14	Zinc alloy	±0.083°	0.23kg	3 screws
55055-04	A600	140x140x30	Zinc alloy	±0.05°	0.45kg	



Applications

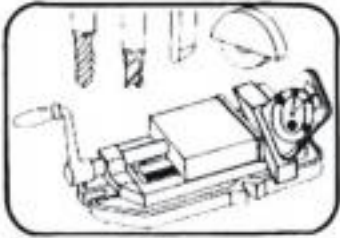

1. Suitable for milling

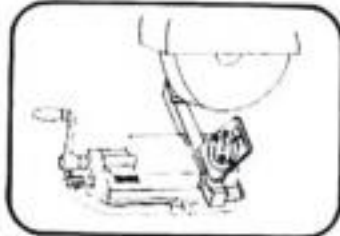

2. Suitable for grinding

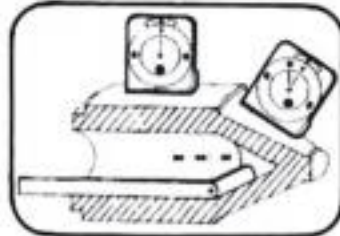

3. Outer & inner cone angle

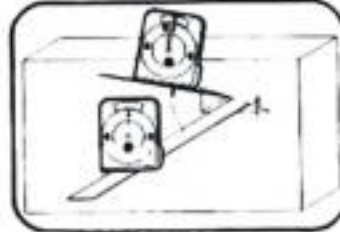

4. Inner angle



5. For screw angle

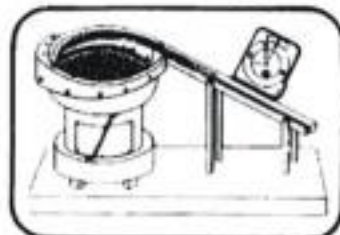

6. Double lines

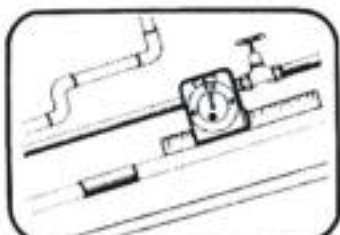

7. Tube piping

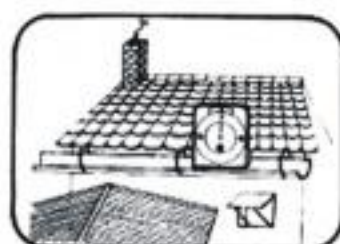

8. D.I.Y.

**Finding an angle**  
Align the movable degree scale,  $0^\circ$  reading, in line with the fixed vernier,  $0^\circ$  mark. Set your instrument's bottom surface on the object to be measured. Your reading off the pointer is your angle of inclination from  $0^\circ$ .

**Setting specific angles**  
Align the desired angle on the movable scale to the vernier's  $0^\circ$  degree mark, Tilt the instrument until the pointer is aligned with the  $0^\circ$  mark



9. Satellite antenna

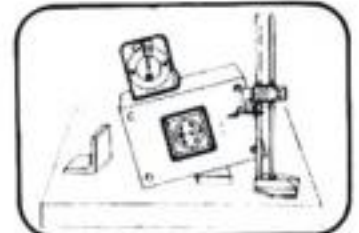

10. Mold-making

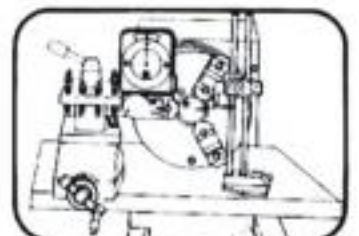

11. On Lathe

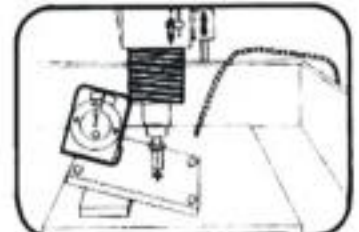

12. On EDM

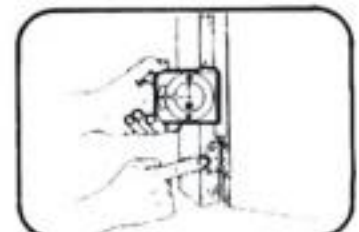

13. Frame angle

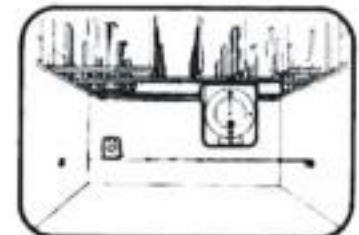

14. Carpentry

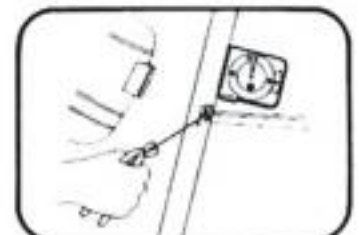

15. Welding

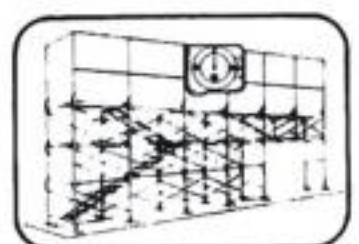

16. Frame assembly.

Vernier reading

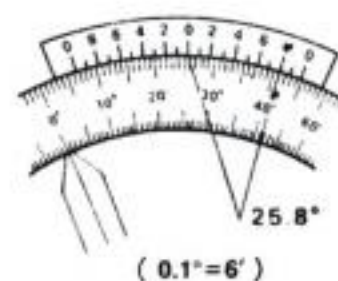
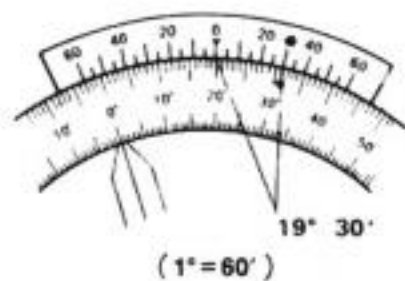

Counter-clockwise



Clockwise



align  $0^\circ$

# Measuring Tool

## 55062 VC Precision Measure Holding Tool



N.W. 0.26kg



N.W. 0.47kg

### Features:

- ▶ Suitable for projector, microscope, loupe, CMM to clamp small workpiece.
- ▶ Clamping range: Max. Thickness is 15mm
  - ◊1.0mm~◊11.0mm(VC30)
  - ◊2.5mm~◊16.0mm(VC45)
- ▶ Made of ASSAB-STAVAX with HRC50°~55°

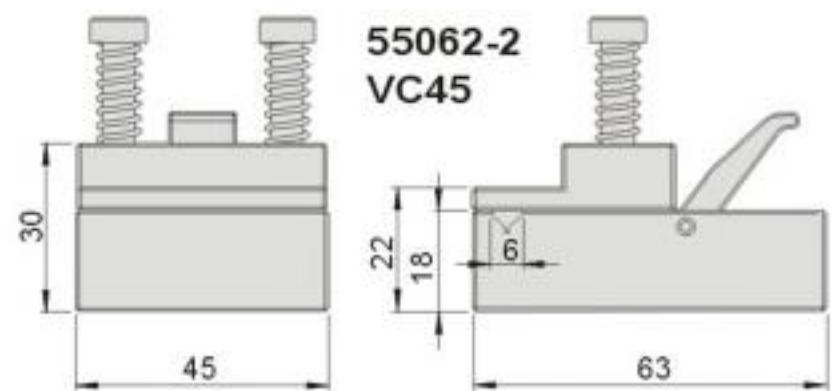
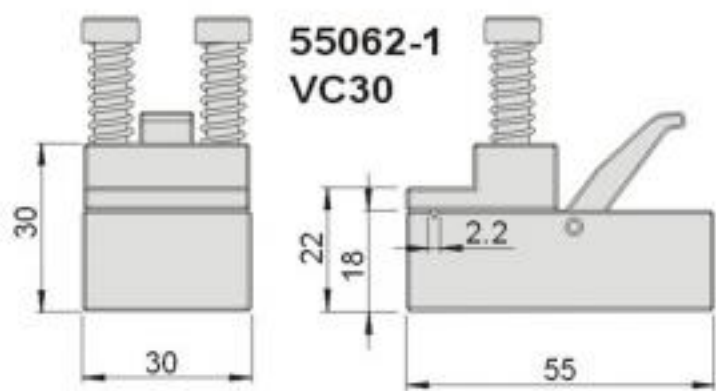

## 55070 GB Gauge Blocks



### Features:

- ▶ Suitable for collocation with sine magnetic chuck or sine dresser to adjust angles.
- ▶ Three specs. available, center distance, 50mm / 75mm / 100mm
- ▶ 46 pcs / set from 1° to 46° each block.
- ▶ Material: SKS3 , HRC60° ~ 62°

Order No.	Model	Center distance
55070-50	GB50P	50m/m
55070-75	GB75P	75m/m
55070-100	GB100P	100m/m

### Examples:



MEASURING TOOL

## 55070 SINE ANGLE CALCULATE TABLE

Order No.	55070-50	55070-75	55070-100
0°	0.00000	0.00000	0.00000
1°	0.87262	1.30893	1.74524
2°	1.74497	2.61746	3.48995
3°	2.61680	3.92520	5.23360
4°	3.48782	5.23174	6.97565
5°	4.35779	6.53668	8.71557
6°	5.22642	7.83963	10.45285
7°	6.09347	9.14020	12.18693
8°	6.95866	10.43798	13.91731
9°	7.82172	11.73258	15.64345
10°	8.68241	13.02361	17.36482
11°	9.54045	14.31067	19.08090
12°	10.39558	15.59338	20.79117
13°	11.24755	16.87133	22.49511
14°	12.09609	18.14414	24.19219
15°	12.94095	19.41143	25.88190
16°	13.78187	20.67280	27.56374
17°	14.61859	21.92788	29.23717
18°	15.45085	23.17627	30.90170
19°	16.27841	24.41761	32.55682
20°	17.10101	25.65151	34.20201
21°	17.91840	26.87760	35.83679
22°	18.73033	28.09549	37.46066
23°	19.53656	29.30483	39.07311
24°	20.33683	30.50525	40.67366
25°	21.13091	31.69637	42.26183
26°	21.91856	32.87784	43.83711
27°	22.69952	34.04929	45.39905
28°	23.47358	35.21037	46.94716
29°	24.24048	36.36072	48.48096
30°	25.00000	37.50000	50.00000
31°	25.75190	38.62786	51.50381
32°	26.49596	39.74394	52.99193
33°	27.23195	40.84793	54.46390
34°	27.95965	41.93947	55.91929
35°	28.67882	43.01823	57.35764
36°	29.38926	44.08389	58.77853
37°	30.09075	45.13613	60.18150
38°	30.78307	46.17461	61.56615
39°	31.46602	47.19903	62.93204
40°	32.13938	48.20907	64.27876
41°	32.80295	49.20443	65.60590
42°	33.45653	50.18480	66.91306
43°	34.09992	51.14988	68.19984
44°	34.73292	52.09938	69.46584
45°	35.35534	53.03301	70.71068
46°	35.96699	53.95049	71.93398

# Measuring Tool

**55080**

**GBH**

**High Speed Steel Metric Gauge Blocks**



## Features :

- ▲ Suitable for adjusting, inspecting measuring instrument and precision tools.
- ▲ Collocation with several gauge blocks is feasible.
- ▲ Demagnetized and special heat treatment with over HRC 64°, specs. are stable.

### Class 1

Used in calibrating electrical measurement instrument in inspection area.

### Class 2

Used in factory floor for calibrating clamping tools or measurement instrument.

### Class 0

Applied in controlled environment by senior inspection members, for calibration and benchmarking.

Order No.	Model	Total blocks	Class	Nominal dimension (mm)	Steps (mm)	No. Of blocks	N.W.
55080-32-0	GB32H <sub>0</sub>	32	0	1.005	0.01	1	0.40kg
55080-32-1	GB32H <sub>1</sub>	32	1	1.01-1.09	0.1	9	
55080-32-2	GB32H <sub>2</sub>	32	2	1.1-1.9	1	9	
				1-10	-	10	
55080-38-0	GB38H <sub>0</sub>	38	0	20,30,50	-	3	1.26kg
55080-38-1	GB38H <sub>1</sub>	38	1	1	0.01	1	
55080-38-2	GB38H <sub>2</sub>	38	2	1.005	0.1	9	
				1.01-1.09	1	9	
55080-47-0	GB47H <sub>0</sub>	47	0	2-10	10	9	1.39kg
55080-47-1	GB47H <sub>1</sub>	47	1	1.1-1.9	0.01	19	
55080-47-2	GB47H <sub>2</sub>	47	2	20-100	0.1	8	
				1	1	9	
55080-87-0	GB87H <sub>0</sub>	87	0	1.001-1.009	0.001	9	1.68kg
55080-87-1	GB87H <sub>1</sub>	87	1	1.01-1.49	0.01	49	
55080-87-2	GB87H <sub>2</sub>	87	2	0.5-9.5	0.5	19	
				10-100	10	10	
55080-103-0	GB103H <sub>0</sub>	103	0	1.005	-	1	2.19kg
55080-103-1	GB103H <sub>1</sub>	103	1	1.01-1.49	0.01	49	
55080-103-2	GB103H <sub>2</sub>	103	2	0.5-24.5	0.5	49	
				25-100	25	4	
55080-112-0	GB112H <sub>0</sub>	112	0	1.0005	-	1	2.23kg
55080-112-1	GB112H <sub>1</sub>	112	1	1.001-1.009	0.001	9	
55080-112-2	GB112H <sub>2</sub>	112	2	1.01-1.49	0.01	49	
				0.5-24.5	0.5	49	
				25-100	25	4	

Unit:mm

**55090**
**GBC**
**Carbide Metric Gauge Blocks**

**Features :**

- ▶ Suitable for adjusting, inspecting measuring instrument and precision tools.
- ▶ Collocation with several gauge blocks is feasible.
- ▶ Demagnetized and special heat treatment with over HRC  $72^{\circ} \pm 2^{\circ}$ , specs. are stable and uneasily deform.

**Class 1**

Used in calibrating electrical measurement instrument in inspection area.

**Class 2**

Used in factory floor for calibrating clamping tools or measurement instrument.

**Class 0**

Applied in controlled environment by senior inspection members, for calibration and benchmarking.

Unit:mm

Order No.	Model	Total blocks	Class	Nominal dimension (mm)	Steps (mm)	No. Of blocks	N.W.
55090-32-0	GB32C <sub>0</sub>	32	0	1.005	0.01	1	0.70kg
55090-32-1	GB32C <sub>1</sub>	32	1	1.01-1.09	0.1	9	
55090-32-2	GB32C <sub>2</sub>	32	2	1.1-1.9 1-10 20,30,50	1 - -	9 10 3	
55090-38-0	GB38C <sub>0</sub>	38	0	1	-	1	2.37kg
55090-38-1	GB38C <sub>1</sub>	38	1	1.005 1.01-1.09 1.1-1.9	- 0.01 0.1	1 9 9	
55090-38-2	GB38C <sub>2</sub>	38	2	2-10 20-100	1 10	9 9	
55090-47-0	GB47C <sub>0</sub>	47	0	1	-	1	2.5kg
55090-47-1	GB47C <sub>1</sub>	47	1	1.005 1.01-1.19 1.1-1.9	- 0.01 0.1	1 19 8	
55090-47-2	GB47C <sub>2</sub>	47	2	2-10 20-100	1 10	9 9	
55090-87-0	GB87C <sub>0</sub>	87	0	1.001-1.009	0.001	9	3.2kg
55090-87-1	GB87C <sub>1</sub>	87	1	1.01-1.49 0.5-9.5	0.01 0.5	49 19	
55090-87-2	GB87C <sub>2</sub>	87	2	10-100	10	10	
55090-103-0	GB103C <sub>0</sub>	103	0	1.005	-	1	4.26kg
55090-103-1	GB103C <sub>1</sub>	103	1	1.01-1.49 0.5-24.5	0.01 0.5	49 49	
55090-103-2	GB103C <sub>2</sub>	103	2	25-100	25	4	
55090-112-0	GB112C <sub>0</sub>	112	0	1.0005	-	1	4.2kg
55090-112-1	GB112C <sub>1</sub>	112	1	1.001-1.009 1.01-1.49 0.5-24.5	0.001 0.01 0.5	9 49 49	
55090-112-2	GB112C <sub>2</sub>	112	2	25-100	25	4	

# Measuring Tool

**55100**

GBD

Ceramic Gauge Blocks



## Features:

- ▲ High wear resistance, 5 to 10 times longer lifecycle than steel.
- ▲ With super precision surface treatment, ensure stable and uneasily affected by temperature.
- ▲ High anti-corrosion, can used for long period of time.

### Class 1

Used in calibrating electrical measurement instrument in inspection area.

### Class 2

Used in factory floor for calibrating clamping tools or measurement instrument.

### Class 0

Applied in controlled environment by senior inspection members, for calibration and benchmarking.

Unit:mm

Order No.	Model	Total blocks	Class	Nominal dimension (mm)	Steps (mm)	No. Of blocks
55100-32-0	GB32D <sub>0</sub>	32	0	1.005 1.01-1.09 1.1-1.9	0.01 0.1 1	1 9 9
55100-32-1	GB32D <sub>1</sub>	32	1	1-10 20,30,50	-	10 3
55100-38-0	GB38D <sub>0</sub>	38	0	1 1.005 1.01-1.09 1.1-1.9	- - 0.01 0.1	1 1 9 9
55100-38-1	GB38D <sub>1</sub>	38	1	2-10 20-100	1 10	9 9
55100-47-0	GB47D <sub>0</sub>	47	0	1 1.005 1.01-1.19 1.1-1.9	- - 0.01 0.1	1 1 19 8
55100-47-1	GB47D <sub>1</sub>	47	1	2-10 20-100	1 10	9 9
55100-87-0	GB87D <sub>0</sub>	87	0	1.001-1.009 1.01-1.49	0.001 0.01	9 49
55100-87-1	GB87D <sub>1</sub>	87	1	0.5-9.5 10-100	0.5 10	19 10
55100-103-0	GB103D <sub>0</sub>	103	0	1.005 1.01-1.49	- 0.01	1 49
55100-103-1	GB103D <sub>1</sub>	103	1	0.5-24.5 25-100	0.5 25	49 4
55100-112-0	GB112D <sub>0</sub>	112	0	1.0005 1.001-1.009 1.01-1.49	- 0.001 0.01	1 9 49
55100-112-1	GB112D <sub>1</sub>	112	1	0.5-24.5 25-100	0.5 25	49 4

**55110**
**GBE**
**High Speed Steel Pin Gauge**

**Features :**

- ▶ Pin gauge is a necessary measuring instrument for checking hole's spec, holes distance and depth of holes.
- ▶ Step spec. is 0.01mm
- ▶ Custom made of diameter accuracy  $\pm 0.5\mu\text{m}$  and  $\pm 0.3\mu\text{m}$  available.

Unit:mm

Order No.	Model	Nominal dimension (mm)	pcs / box	N.W.
55110-0510	GB0510E	0.50, 0.51, 0.52~1.00	51	1.11kg
55110-1015	GB1015E	1.00, 1.01, 1.02~1.50	51	1.13kg
55110-1520	GB1520E	1.50, 1.51, 1.52~2.00	51	1.15kg
55110-2025	GB2025E	2.00, 2.01, 2.02~2.50	51	1.19kg
55110-2530	GB2530E	2.50, 2.51, 2.25~3.00	51	1.23kg
55110-3035	GB3035E	3.00, 3.01, 3.02~3.50	51	1.27kg
55110-3540	GB3540E	3.50, 3.51, 3.52~4.00	51	1.33kg
55110-4045	GB4045E	4.00, 4.01, 4.02~4.50	51	1.39kg
55110-4550	GB4550E	4.50, 4.51, 4.52~5.00	51	1.47kg
55110-5055	GB5055E	5.00, 5.01, 5.02~5.50	51	1.55kg
55110-5560	GB5560E	5.50, 5.51, 5.52~6.00	51	1.63kg
55110-6065	GB6065E	6.00, 6.01, 6.02~6.50	51	1.73kg
55110-6570	GB6570E	6.50, 6.51, 6.52~7.00	51	1.83kg
55110-7075	GB7075E	7.00, 7.01, 7.02~7.50	51	1.95kg
55110-7580	GB7580E	7.50, 7.51, 7.52~8.00	51	2.07kg
55110-8085	GB8085E	8.00, 8.01, 8.02~8.50	51	2.19kg
55110-8590	GB8590E	8.50, 8.51, 8.52~9.00	51	2.33kg
55110-9095	GB9095E	9.00, 9.01, 9.02~9.50	51	2.47kg
55110-95100	GB95100E	9.50, 9.51, 9.52~10.00	51	2.63kg

**Accuracy:**

$\varnothing$	Step	L	Dia. Accuracy	Roundness acc.
0.05~0.09	0.01	5~10	$\pm 0.5\mu\text{m}$	0.5 $\mu\text{m}$
0.10~0.19	0.01	20	$\pm 0.5\mu\text{m}$	0.5 $\mu\text{m}$
0.20~0.49	0.01	40	$\pm 1\mu\text{m}$	0.8 $\mu\text{m}$
0.50~10.00	0.01	50	$\pm 1\mu\text{m}$	0.8 $\mu\text{m}$
10.01~20.00	0.01	50	$\pm 1.5\mu\text{m}$	1.6 $\mu\text{m}$
20.01~30.00	0.01	50	$\pm 1.5\mu\text{m}$	1.6 $\mu\text{m}$



MEASURING TOOL

# Measuring Tool

**55120**

**GBF**

**Carbide Pin Gauge**



## Features:

- ▶ Pin gauge is a necessary measuring instrument for checking hole's spec, holes distance and depth of holes.
- ▶ Step spec. is 0.01mm
- ▶ Custom made of diameter accuracy  $\pm 0.5\mu\text{m}$  and  $\pm 0.3\mu\text{m}$  is available.

Unit:mm

Order No.	Model	Nominal dimension (mm)	pcs / box	N.W.
55120-0510	GB0510F	0.50, 0.51, 0.52~1.00	51	0.90kg
55120-1015	GB1015F	1.00, 1.01, 1.02~1.50	51	0.94kg
55120-1520	GB1520F	1.50, 1.51, 1.52~2.00	51	1.00kg
55120-2025	GB2025F	2.00, 2.01, 2.02~2.50	51	1.07kg
55120-2530	GB2530F	2.50, 2.51, 2.25~3.00	51	1.17kg
55120-3035	GB3035F	3.00, 3.01, 3.02~3.50	51	1.28kg
55120-3540	GB3540F	3.50, 3.51, 3.52~4.00	51	1.42kg
55120-4045	GB4045F	4.00, 4.01, 4.02~4.50	51	1.57kg
55120-4550	GB4550F	4.50, 4.51, 4.52~5.00	51	1.74kg
55120-5055	GB5055F	5.00, 5.01, 5.02~5.50	51	1.93kg
55120-5560	GB5560F	5.50, 5.51, 5.52~6.00	51	2.14kg
55120-6065	GB6065F	6.00, 6.01, 6.02~6.50	51	2.37kg
55120-6570	GB6570F	6.50, 6.51, 6.52~7.00	51	2.62kg
55120-7075	GB7075F	7.00, 7.01, 7.02~7.50	51	2.88kg
55120-7580	GB7580F	7.50, 7.51, 7.52~8.00	51	3.17kg
55120-8085	GB8085F	8.00, 8.01, 8.02~8.50	51	3.47kg
55120-8590	GB8590F	8.50, 8.51, 8.52~9.00	51	3.80kg
55120-9095	GB9095F	9.00, 9.01, 9.02~9.50	51	4.14kg
55120-95100	GB95100F	9.50, 9.51, 9.52~10.00	51	4.50kg

## Accuracy:

$\varnothing$	Step	L	Dia. Accuracy	Roundness acc.
0.05~0.09	0.01	5~10	$\pm 0.5\mu\text{m}$	0.5 $\mu\text{m}$
0.10~0.19	0.01	20	$\pm 0.5\mu\text{m}$	0.5 $\mu\text{m}$
0.20~0.49	0.01	40	$\pm 1\mu\text{m}$	0.8 $\mu\text{m}$
0.50~10.00	0.01	50	$\pm 1\mu\text{m}$	0.8 $\mu\text{m}$
10.01~20.00	0.01	50	$\pm 1.5\mu\text{m}$	1.6 $\mu\text{m}$
20.01~30.00	0.01	50	$\pm 1.5\mu\text{m}$	1.6 $\mu\text{m}$



**55130**
**GBG**
**Ceramic Pin Gauge**

### Features :

- ▶ Pin gauge is a necessary measuring instrument for checking hole's spec, holes distance and depth of holes.
- ▶ Step spec. is 0.01mm
- ▶ Custom made of diameter accuracy  $\pm 0.5\mu$  and  $\pm 0.3\mu$  available.

Unit:mm

Order No.	Model	Nominal dimension (mm)	pcs / box	N.W.
55130-0510	GB0510G	0.50, 0.51, 0.52~1.00	51	0.88kg
55130-1015	GB1015G	1.00, 1.01, 1.02~1.50	51	0.89kg
55130-1520	GB1520G	1.50, 1.51, 1.52~2.00	51	0.90kg
55130-2025	GB2025G	2.00, 2.01, 2.02~2.50	51	0.91kg
55130-2530	GB2530G	2.50, 2.51, 2.25~3.00	51	0.92kg
55130-3035	GB3035G	3.00, 3.01, 3.02~3.50	51	0.93kg
55130-3540	GB3540G	3.50, 3.51, 3.52~4.00	51	0.95kg
55130-4045	GB4045G	4.00, 4.01, 4.02~4.50	51	0.97kg
55130-4550	GB4550G	4.50, 4.51, 4.52~5.00	51	0.99kg
55130-5055	GB5055G	5.00, 5.01, 5.02~5.50	51	1.01kg
55130-5560	GB5560G	5.50, 5.51, 5.52~6.00	51	1.04kg
55130-6065	GB6065G	6.00, 6.01, 6.02~6.50	51	1.06kg
55130-6570	GB6570G	6.50, 6.51, 6.52~7.00	51	1.09kg
55130-7075	GB7075G	7.00, 7.01, 7.02~7.50	51	1.13kg
55130-7580	GB7580G	7.50, 7.51, 7.52~8.00	51	1.16kg
55130-8085	GB8085G	8.00, 8.01, 8.02~8.50	51	1.20kg
55130-8590	GB8590G	8.50, 8.51, 8.52~9.00	51	1.24kg
55130-9095	GB9095G	9.00, 9.01, 9.02~9.50	51	1.28kg
55130-95100	GB95100G	9.50, 9.51, 9.52~10.00	51	1.32kg

### Accuracy:

$\varnothing$	Step	L	Dia. Accuracy	Roundness acc.
0.05~0.09	0.01	5~10	$\pm 0.5\mu\text{m}$	0.5 $\mu\text{m}$
0.10~0.19	0.01	20	$\pm 0.5\mu\text{m}$	0.5 $\mu\text{m}$
0.20~0.49	0.01	40	$\pm 1\mu\text{m}$	0.8 $\mu\text{m}$
0.50~10.00	0.01	50	$\pm 1\mu\text{m}$	0.8 $\mu\text{m}$
10.01~20.00	0.01	50	$\pm 1.5\mu\text{m}$	1.6 $\mu\text{m}$
20.01~30.00	0.01	50	$\pm 1.5\mu\text{m}$	1.6 $\mu\text{m}$

MEASURING TOOL

# Measuring Tool

**55160**

TSOE

Optical Edge Finder (Touch Point Sensor)

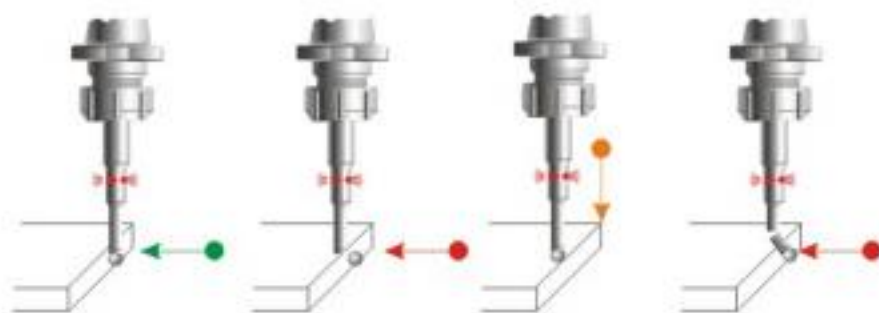

## Features :

- ▶ No rotation needed while measuring.
- ▶ Increase efficiency to find positions and work edges.
- ▶ Safety spring puller which holds the ball back to the position when ball breaks from ball seat.
- ▶ Accuracy 0.005mm
- ▶ Battery type:  
Um5#, 1.5V x 2pcs (TSOE20L, 32L)  
Um5#, 23A x 12V x 1pc (TSOE20S, 20LB, 32LB)

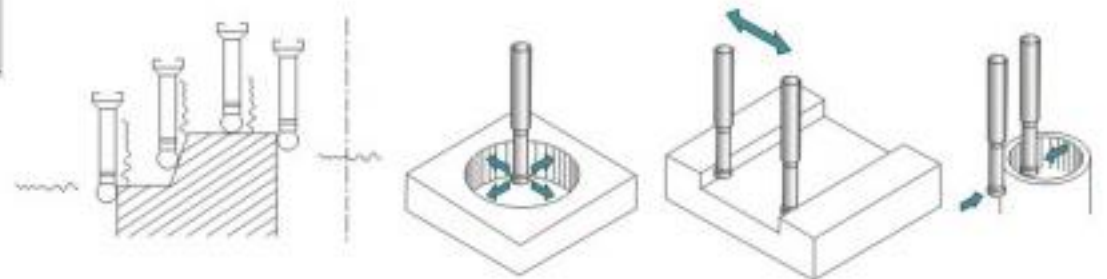
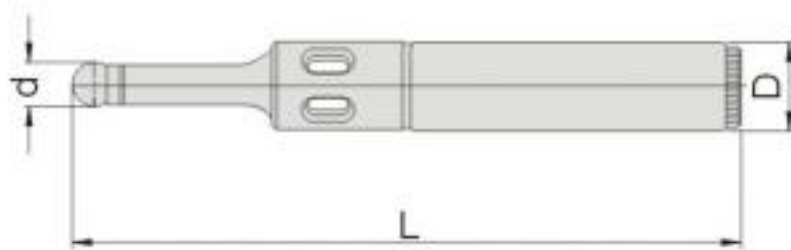

Attention! This product is not suitable for rotary.

Unit:mm

Order No.	Model	D	L	d	FEATURE	LxWxH	N.W.
55160-02	TSOE20S	ø20	120	ø10	Lighting	198x75x44	0.35kgs
55160-04	TSOE20L		158		Lighting		0.40kgs
55160-06	TSOE20LB		158		Sound		0.40kgs
55160-08	TSOE32L	ø32	158		Lighting		0.70kgs
55160-10	TSOE32LB		158		Sound		0.70kgs

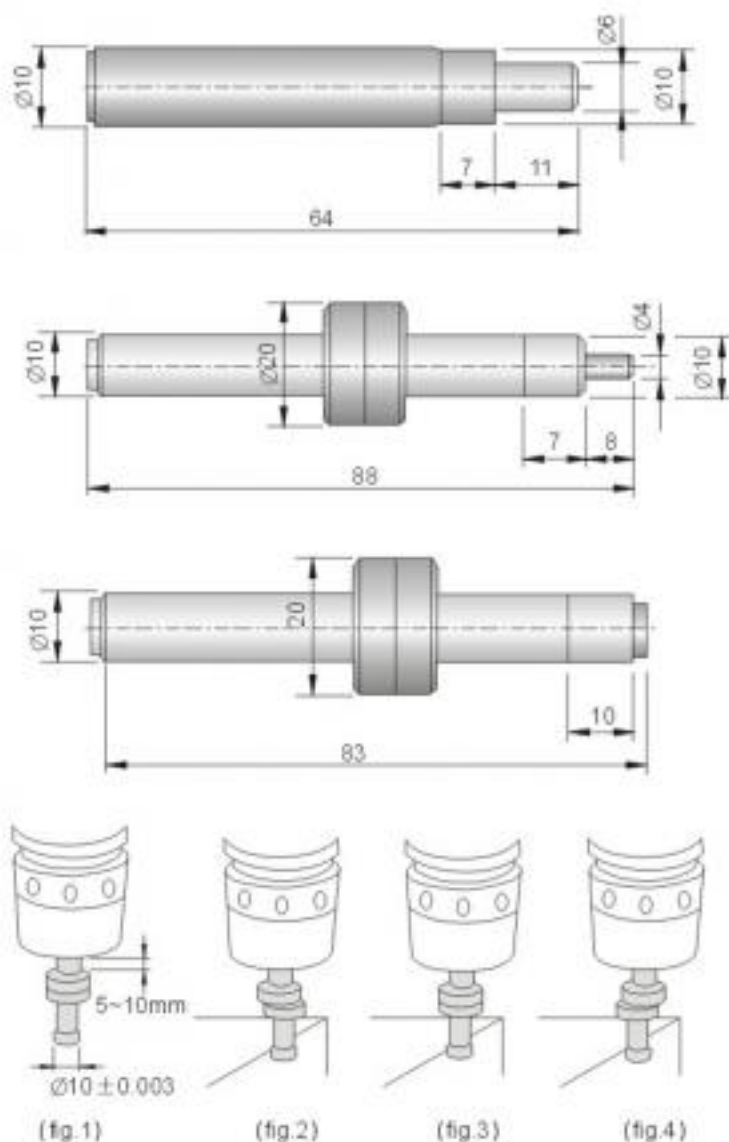

### Features:

- ▶  $\varnothing 10$  straight shank can be installed directly on milling chuck or drilling chuck. (see fig. 1).
- ▶ Slightly press on the edge of sensor unit to make it eccentric at 0.5mm (see fig. 2).
- ▶ Rotate with speed of 400 ~ 600 rpm.
- ▶ Make sensor unit contact to the end face of workpiece as shown Fig. 2, then move steadily until turning into Fig. 3 looks keep still. When making fine-moving and it looks as Fig. 4, and this coordinate position is the basis point.
- ▶ The position of end face of the workpiece is the coordinate position of sensor unit plus radius 5mm.

### Cautions:

1. Do not bend the product or pull with force.
2. Always keep clean for the slide face.
3. Never apply over 600 rpm.
4. Never apply it on horizontal machinery.

Material:Cr-Mo Alloy Steel HRC58<sup>o</sup>~60<sup>o</sup>

Unit:mm

Order No.	Model	LxWxH	N.W.
55170-02	TS0610	94x24x24	0.08kgs
55170-04	TS1020	94x24x24	0.04kgs
55170-06	TS0420	94x24x24	0.14kgs
55170-08	TS1020T	94x24x24	0.05kgs
55170-10	TS0420T	94x24x24	0.14kgs
55170-12	TS1020TB	94x24x24	0.12kgs
55170-14	TS0420TB	94x24x24	0.14kgs

“T” (Titanium Nitride)

“TB” (Black Titanium Nitride)

# Measuring Tool

**55180**

TSEP

Ceramic Edge Finder



TSEP10



TSEP1020



TSEP1020A



TSEP1020B

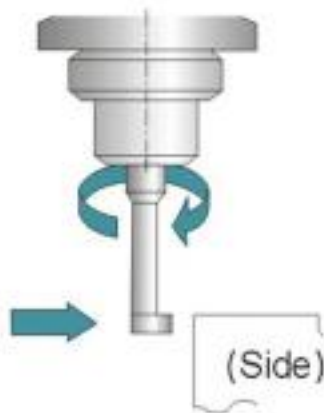
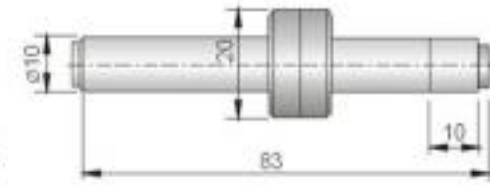

1. Rotate back, and approaching object slowly

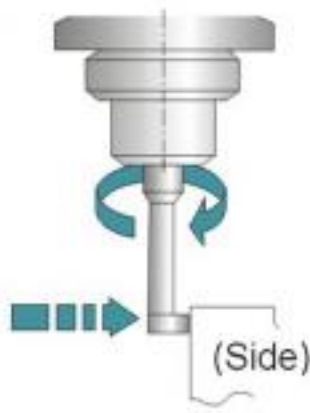

2. Stop moving when contact and vibrates, and move it back.



3. it would be consistent between cylinder and workpiece's face when reaching 5mm in radius.

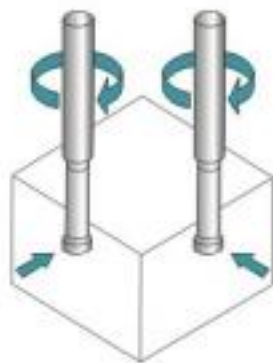

Set up the standard position.

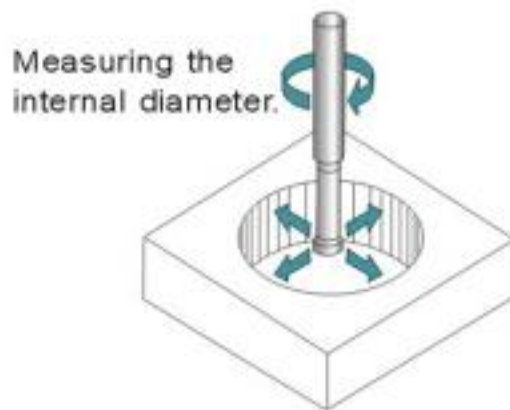

Measuring the internal diameter.

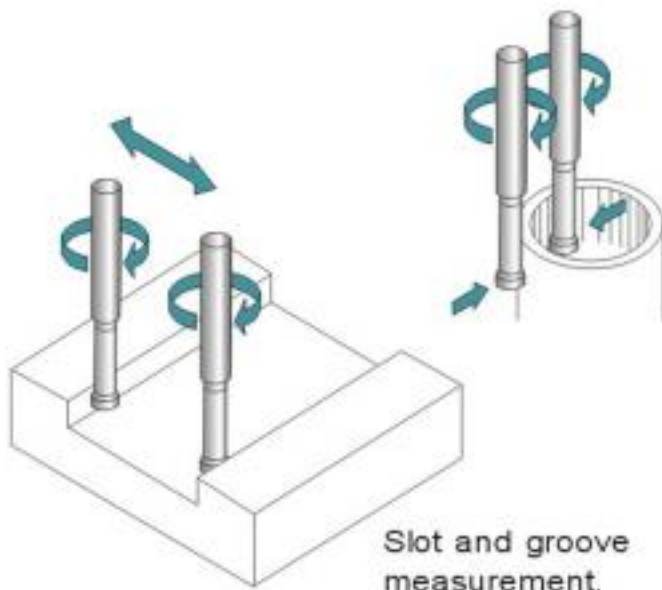
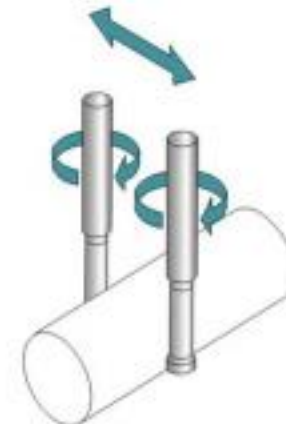

Slot and groove measurement.

TSEP type is non-magnetic and the front tip is made of ceramic.  
Ceramic HV:1350°

Unit:mm

Order No.	Model	Package LxWxH	N.W.
55180-02	TSEP10(WHITE)	118x42x25	0.1kg
55180-04	TSEP10(BLACK)	118x42x25	0.1kg
55180-06	TSEP1020	118x42x25	0.1kg
55180-08	TSEP1020A	118x42x25	0.1kg
55180-10	TSEP1020B	118x42x25	0.1kg

**55182**

**TSOP**

**Optical 3D High Precision Edge Finder**



Scan me  
Product video

■ MADE  
■ IN  
■ GERMANY

### Features :

- ▶ Determine your workpiece position / location and check/ control the accuracy of your workpiece.
- ▶ Status display clearly visible to the user
- ▶ Excellent in cost-benefit ratio
- ▶ Within all three axis, the accuracy of probing is smaller than 0.005mm

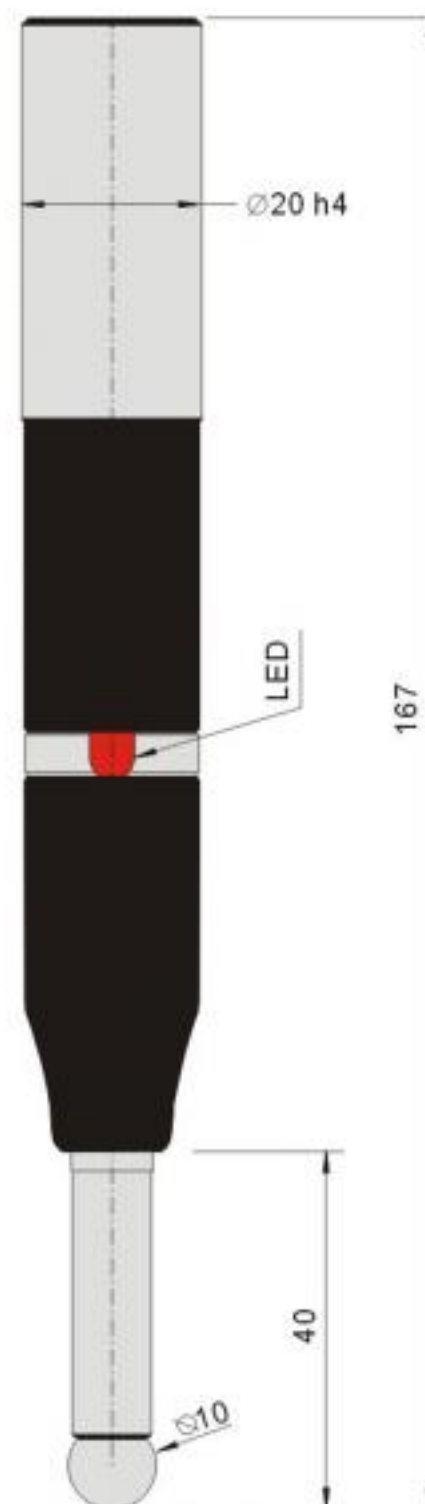

MEASURING TOOL

# Measuring Tool

**55184**

ZST

Z-Axis Presetter (Optical Type)



- MADE
- IN
- GERMANY

## Features:

- ▶ To determine the position of workpiece surfaces or tool lengths in Z-direction at milling machines or lathes.
- ▶ The zero setter is placed on the workpiece.
- ▶ The spindle has to be moved carefully onto the tracer until the dial gauge indicates "0".
- ▶ The reference dimension 60 mm to the workpiece has been reached. A safety spring range of max. 2 mm is included.

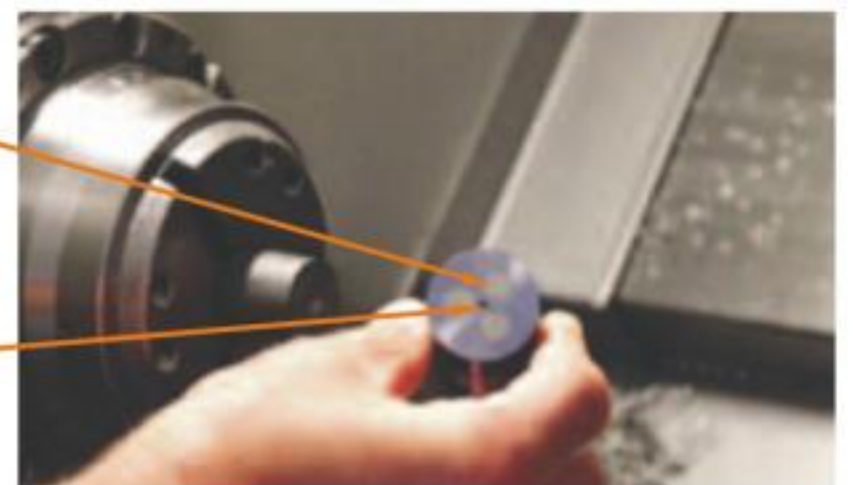

Secure horizontal grip thanks to 3  $\varnothing 8$  powerful magnetic

Tolerance for turning scrap, avoids measuring faults.

Unit:mm

Order No.	Model	Min.Capacity	Height	Body	Tester	N.W.	Remark
55184	ZST60P	$\varnothing 0.1$	60	$\varnothing 32$	$\varnothing 19$	0.35kgs	Magnet

**55186**
**ZSM**
**Z-Axis Presetter (Indicator Type)**

- MADE
- IN
- GERMANY



Scan me  
Product video

- Simple adjustment:
- Push tester.
  - Small indicator at -2mm.
  - Turn scale for large indicator to 0.
  - Ready!



Micro tools:  
We even measured milling tools with  $\varnothing 0,1$  mm without any problems

### Features:

- ▶ To determine the position of workpiece surfaces or tool lengths in Z-direction at milling machines or lathes.
- ▶ The zero setter is placed on the workpiece.
- ▶ The spindle has to be moved carefully onto the tracer until the dial gauge indicates "0".
- ▶ The reference dimension 100 mm to the workpiece has been reached. A safety spring range of max. 2 mm is included.

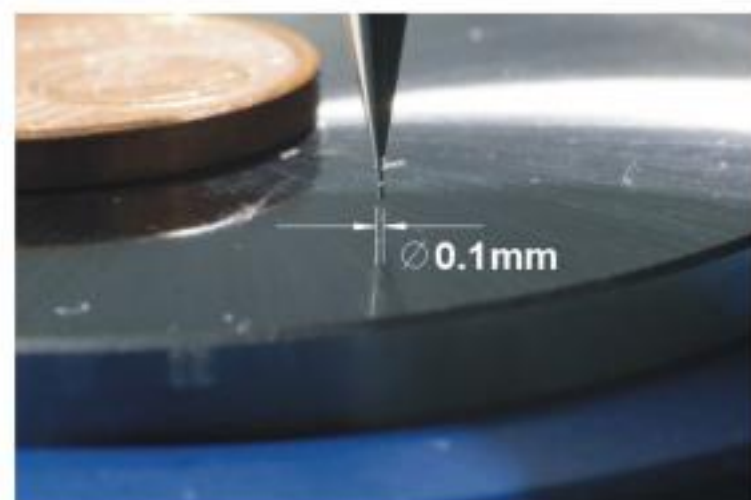

MEASURING TOOL

Unit:mm

Order No.	Model	Min.Capacity	Height	Body	Tester	N.W.	Remark
55186-01	ZSM100	$\varnothing 0.1$	100	$\varnothing 54.5$	$\varnothing 42$	1.8kgs	Non-mag
55186-02	ZSM100P	$\varnothing 0.1$	100	$\varnothing 54.5$	$\varnothing 42$	1.8kgs	Magnet

# Measuring Tool

## 55190 ZIP50 Z-Axis Presetter (Indicator Type)



### Features :

- ▶ Setting tool length on CNC milling and lathe machines
- ▶ Setting height:  $50 \pm 0.005\text{mm}$ .
- ▶ Large measuring surface and easily operated.
- ▶ Low spring force to avoid breakage of small end mill or drill.
- ▶ Easily calibrated by ground parallel or gauge blocks.

Unit:mm

Order No.	Model	Height	LxWxH	N.W.	Remark
55190-01	ZIP50	$50 \pm 0.005$	101x101x90	0.59kgs	Non-mag
55190-02	ZIP50P	$50 \pm 0.005$	101x101x90	0.59kgs	Magnet

## 55200 ZIP50A Z-Axis Presetter (Indicator Type)



### Features :

- ▶ Setting tool length on CNC milling and lathe machines
- ▶ Setting height:  $50 \pm 0.005\text{mm}$ .
- ▶ Large measuring surface and easily operated.
- ▶ Low spring force to avoid breakage of small end mill or drill.
- ▶ Easily calibrated by ground parallel or gauge blocks.
- ▶ ZIP-50A with better parallel, sensibility and accuracy.

Unit:mm

Order No.	Model	Height	LxWxH	N.W.	Remark
55200-01	ZIP50A	$50 \pm 0.005$	101x101x90	1.06kgs	Non-mag
55200-02	ZIP50AP	$50 \pm 0.005$	101x101x90	1.06kgs	Magnet



**55210**

Z50

Z-Axis Zero Setter



N.W. 1.25kg

### Features :

- ▶ Setting tool length on CNC milling and lathe machines
- ▶ Setting height:  $50 \pm 0.005\text{mm}$ .
- ▶ Large measuring surface and easily operated.
- ▶ Low spring force to avoid breakage of small end mill or drill.
- ▶ Easily calibrated by ground parallel or gauge blocks.

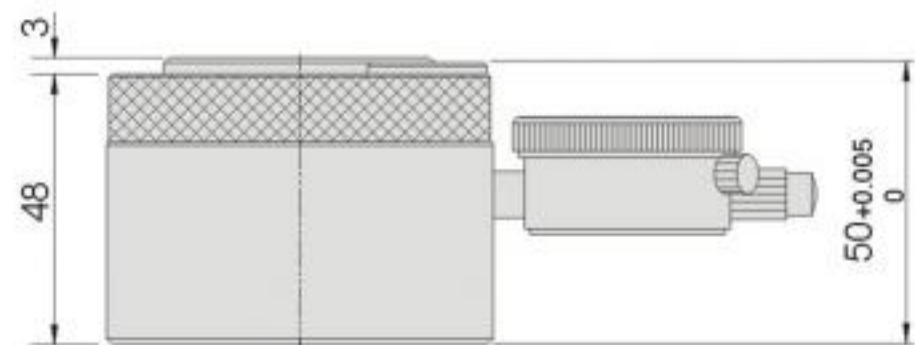
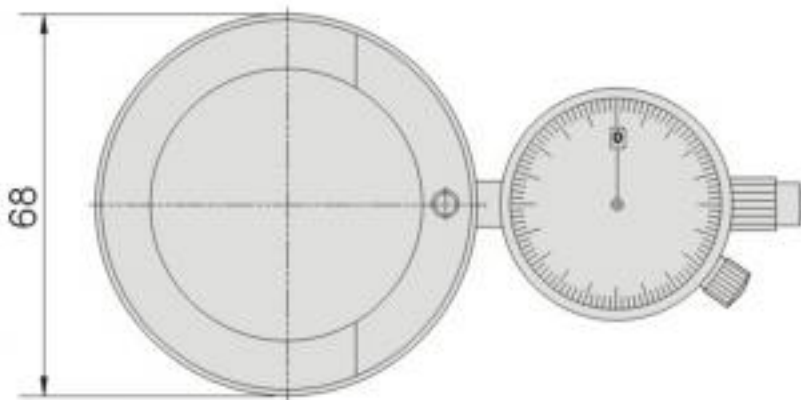

### Instruction:

Calibrate the Zero Setter by putting a parallel on the setter and press it against on the pre-ground surface and set the dial gauge at "0"

### Measurement:

Set up the setter on machine table or workpiece's surface, move spindle to make cutting tool contact the measuring surface and read the dial gauge with care. When the dial gauge points at "0", the distance between tool end and machine table is 50mm.

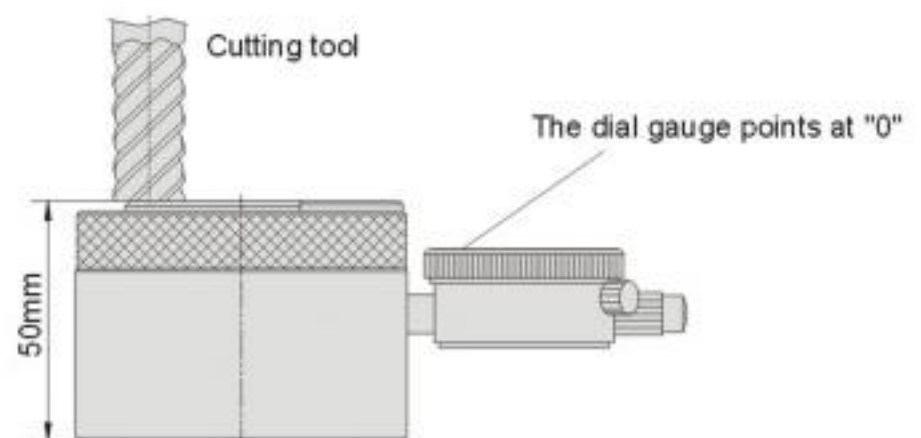
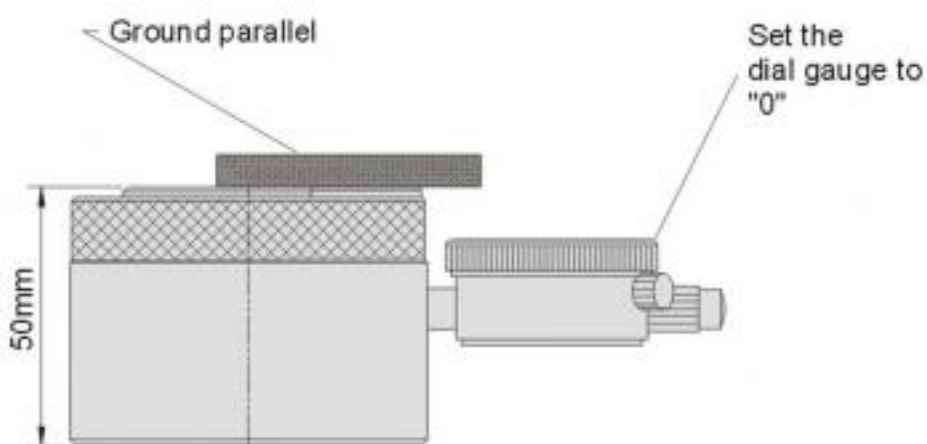

# Measuring Tool

## 55220 ZOP50 Z-Axis Presetter (Optical Type)



### Features:

- ▶ Setting height:  $50 \pm 0.005\text{mm}$ .
- ▶ Magnetic base for easy setup.
- ▶ Red lamp will be lit up when touched.
- ▶ Height can be fine-tuning and calibrated by gauge blocks.
- ▶ Can be used vertically and horizontally.
- ▶ Battery type : LR44 / A76 / G13 x 2 purchase

### Instruction:

Calibrate the Zero Setter by putting a parallel on the setter and press it against on the pre-ground surface and set the dial gauge at "0"

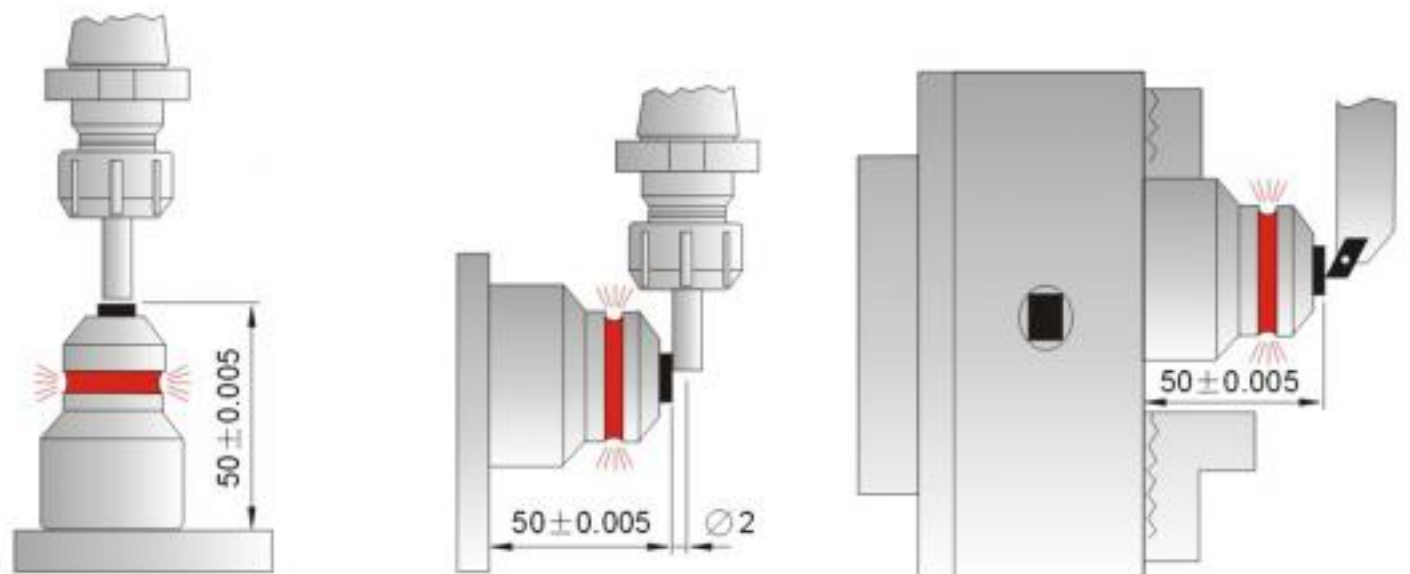

Unit:mm

Order No.	Model	Height	LxWxH	N.W.	Remark
55220-01	ZOP50	$50 \pm 0.005$	101x101x90	0.39kgs	Non-mag
55220-02	ZOP50P	$50 \pm 0.005$	101x101x90	0.39kgs	Magnet

**55230**
**ZPM-50/50P**
**Z Axis Presetter**

**Features :**

- ▶ Least measuring diameter of cutting tool: 0.1mm
- ▶ Not easily scratched for the ceramic made measuring face.
- ▶ Built-in design of gauge.
- ▶ Available for magnetic base or non-magnetic base.
- ▶ Accuracy of the gauge: 0.01mm

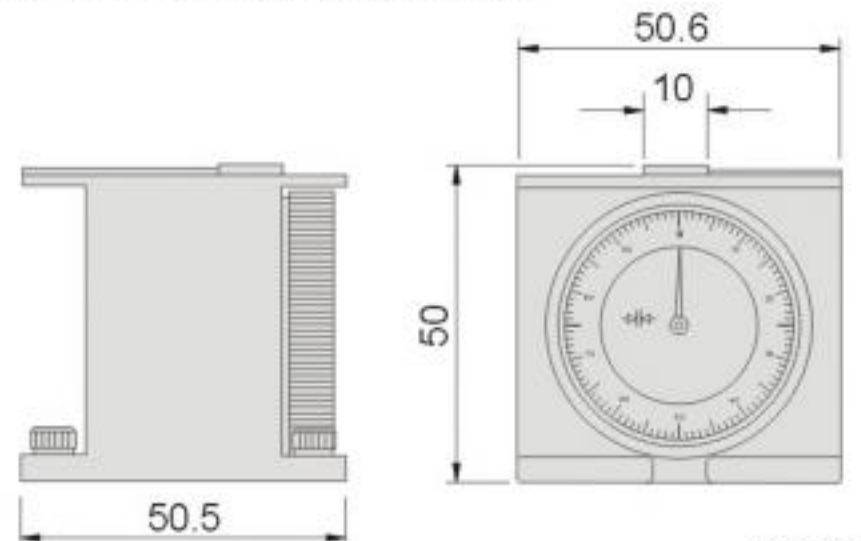

Unit:mm

Order No.	Model	Least dia. Of tool	Height	N.W.	Package size	Remark
55230-01	ZPM-50	0.1mm	50mm	0.5kg	13.5x10.5x8cm	Non-mag
55230-02	ZPM-50P	0.1mm	50mm	0.5kg	13.5x10.5x8cm	Magnet

**55240**
**ZPM-100P**
**Z Axis Presetter(Magnetic)**

**Features :**

- ▶ Least measuring diameter of cutting tool: 0.1mm
- ▶ Not easily scratched for the ceramic made measuring face.
- ▶ Built-in design of gauge.
- ▶ With magnetic base.
- ▶ Accuracy of the gauge: 0.01mm

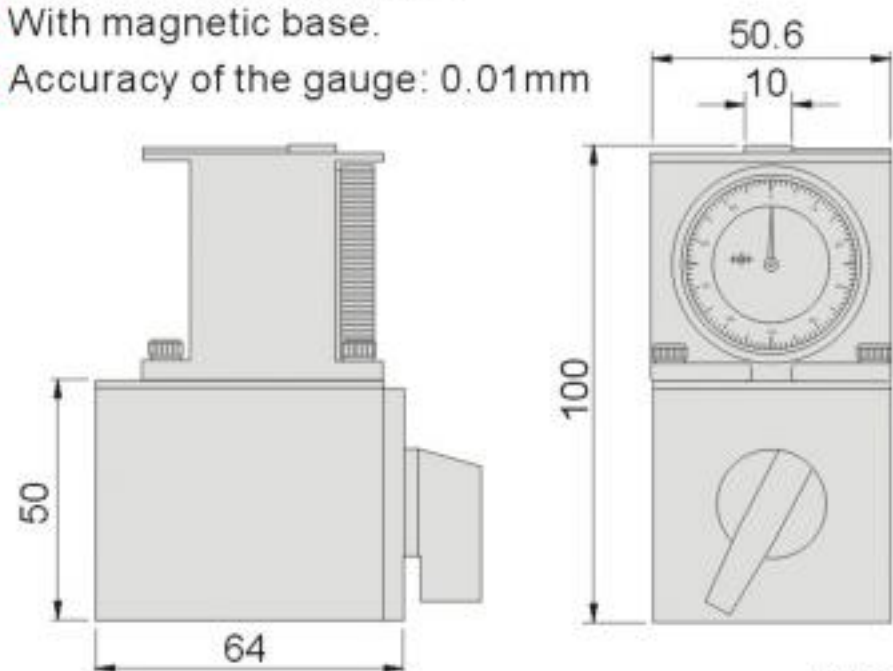

Unit:mm

Order No.	Model	Least dia. Of tool	Height	N.W.	Package size
55240	ZPM-100P	0.1mm	100mm	1.4kg	13.5x10.5x8cm

# Measuring Tool

**55250**

TTC10

Portable For The Tool Setting



## Features :

- ▶ Lightweight and portable compact design to set the length parameter of cutting tool in the CNC milling machine, or drilling machine center and etc
- ▶ Adopting two position indicators for warning to speed up the process of the cutting tool calibration.
- ▶ Three LED indicator lights and a buzzer are used to indicate the working status of the tool setting.
- ▶ It has magnetic base bottom.



## Technical Parameters

- ◆ Battery spec.: CR2, 3.0V, 800 mAh x 1pc
- ◆ Nominal height:  $80.0 \pm 0.003\text{mm}$ ;
- ◆ Diameter of the touching face:  $\varnothing 30\text{mm}$
- ◆ Hardness of the touch face: HRC 60-62°
- ◆ Travel distance of the touch face in -Z direction: 5mm
- ◆ Trigger repeatability of the tool setter:  $\leq 2\mu\text{m}$
- ◆ Parallelism between the touching face and the bottom:  $\leq 3\mu\text{m}$

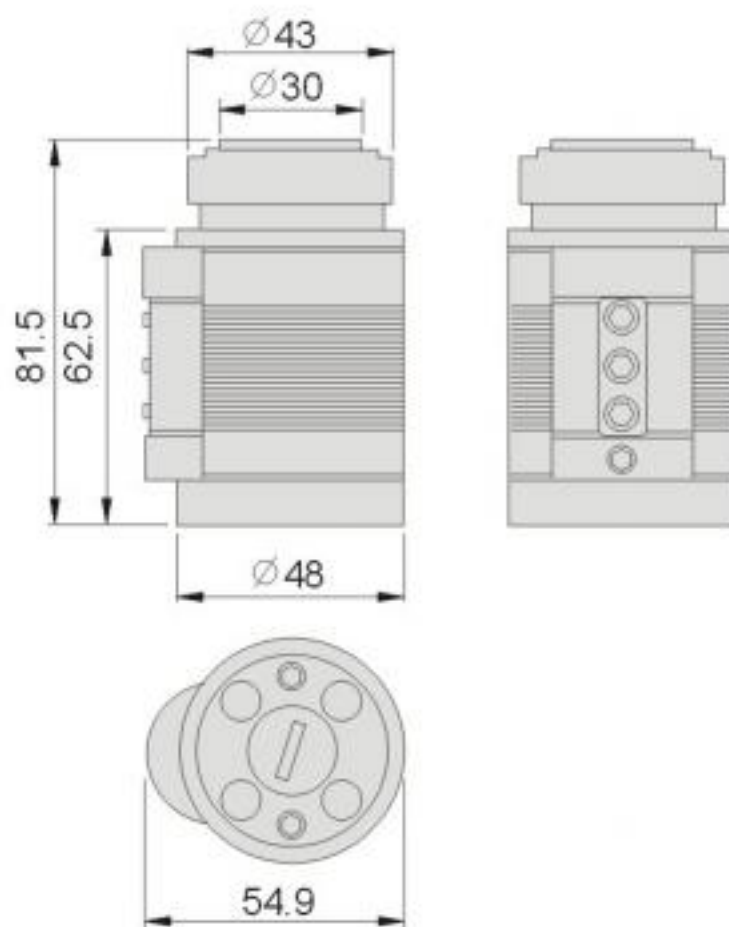

MEASURING TOOL



### Features :

- ▶ Suitable for machine centers, CNC boring and milling machines, and drilling-tapping machine centers etc.
- ▶ Suitable for checking work pieces of all kinds of solid materials with electrical conductivity.
- ▶ By adjusting the connecting link between the main body of the probe and its shank, then coaxial about
- ▶ the center of the measuring ball on the probe and the center line of the shank can be adjusted (Ex-factory precision:  $\leq 5\mu\text{m}$ ).

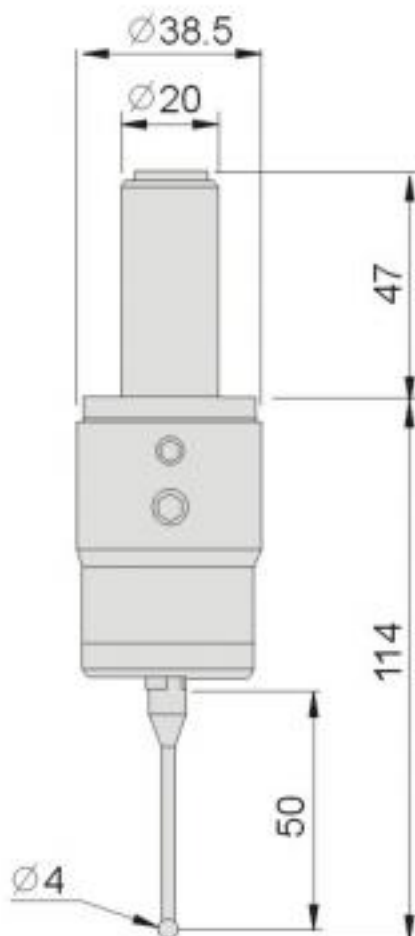

### Technical Parameters

- ◆ The standard: M4-S50-SB4-S36
- ◆ The diameter of the probe's cylindrical shank is  $\varnothing 20\text{mm}$
- ◆ Battery spec.: LR1, 1.5V, 700 mAh x 2pcs
- ◆ Probe sensing direction:  $\pm X, \pm Y, +Z$
- ◆ Probe sensing over-travel :  $X-Y \pm 15^\circ, Z +5\text{ mm}$
- ◆ The trigger force in Z direction: 1000g
- ◆ Trigger force in X-Y surface ( standard probe ) : 65-130g
- ◆ Unidirectional repeatability:  $\leq 2\mu\text{m}$
- ◆ Input voltage is  $24\text{V} \pm 10\%$  DC and output load current is 50 mA.

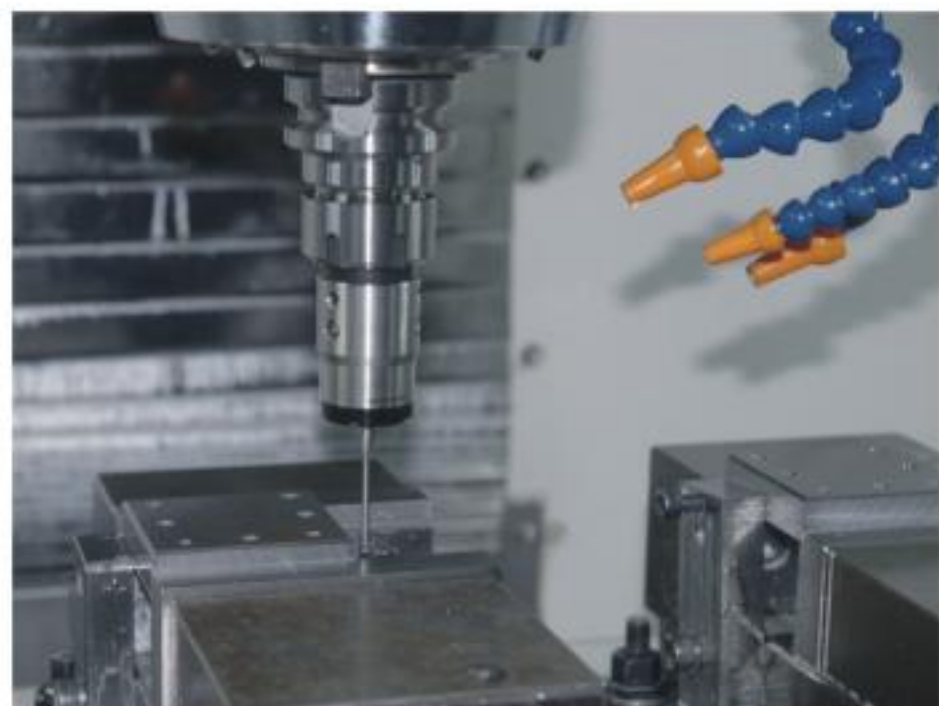

# Measuring Tool

**55260**

EP60

Electric Conducting Probe

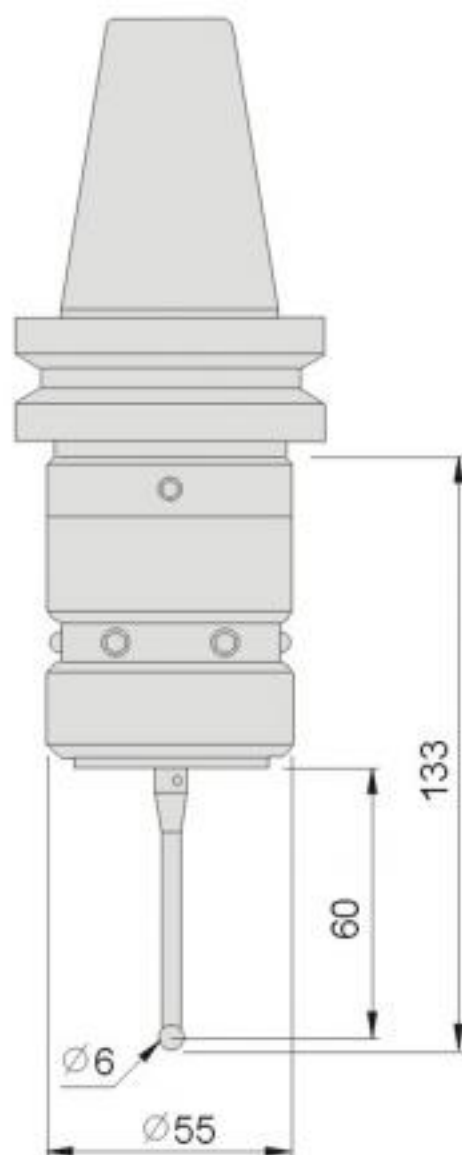

## Features :

- ▶ Suitable for machine centers, CNC boring and milling machines, and drilling-tapping machine centers etc.
- ▶ Suitable for checking work pieces of all kinds of solid materials with electrical conductivity.
- ▶ By adjusting the connecting link between the main body of the probe and its shank, then coaxial about
- ▶ the center of the measuring ball on the probe and the center line of the shank can be adjusted (Ex-factory precision:  $\leq 5\mu\text{m}$ ).
- ▶ Six LED indicator lights are used to show the trigger status of the probe
- ▶ Pull stub for shank/arbor is excluded.

## Technical Parameters

- ◆ The standard: M4-S60-SB6-S58.5
- ◆ Usually, the probe shank is 7:24 taper shank with the BT or ISO standards (the specification is optional );
- ◆ Battery spec.: CR2, 3.0V, 800 mAh x 1pc
- ◆ Probe sensing direction:  $\pm X, \pm Y, +Z$
- ◆ Probe sensing over-travel :  $X\text{-}Y \pm 15^\circ, Z +5\text{ mm}$
- ◆ The trigger force in Z direction: 1000g
- ◆ Trigger force in X-Y surface ( standard probe ) : 65-130g
- ◆ Unidirectional repeatability:  $\leq 2\mu\text{m}$
- ◆ Input voltage is  $24\text{V} \pm 10\%$  DC and output load current is 50 mA.

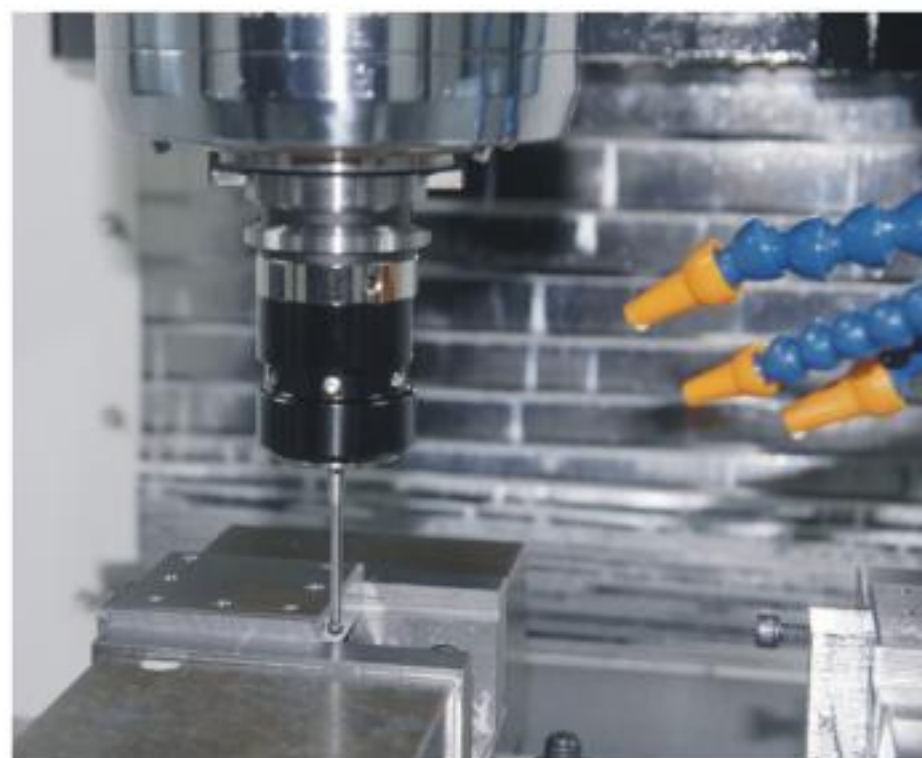

MEASURING TOOL



IP68

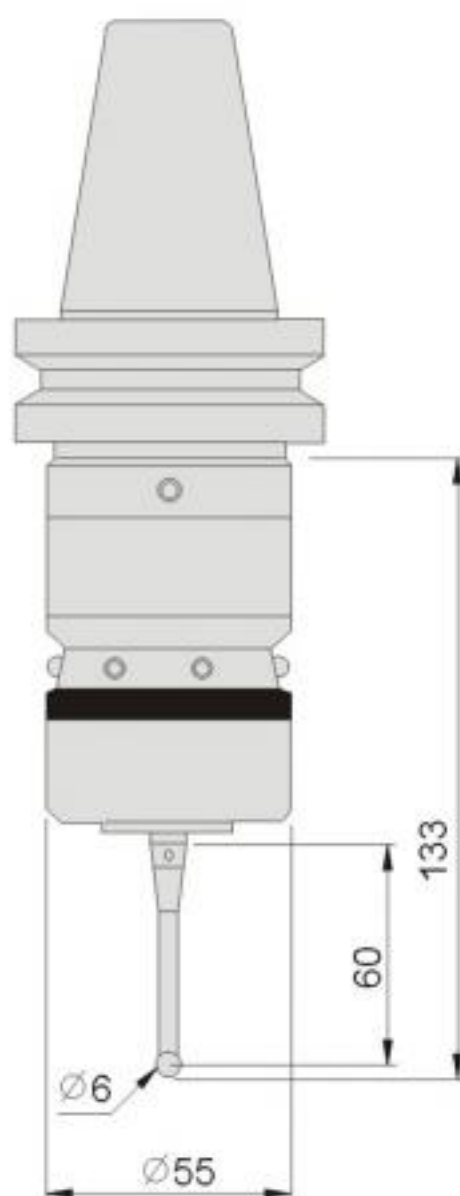

### Features :

- ▶ Suitable for machine centers, CNC boring and milling machines, and drilling-tapping machine centers etc.
- ▶ By adjusting the connecting link between the main body of the probe and its shank, then coaxial about the center of the measuring ball on the probe and the center line of the shank can be adjusted (Ex-factory precision:  $\leq 5\mu\text{m}$ ).
- ▶ Six LED indicator lights are used to show the trigger status of the probe
- ▶ Pull stub for shank/arbor is excluded.

### Technical Parameters

- ◆ The standard: M4-P50-RB6-S36
- ◆ Usually, the probe shank is 7:24 taper shank with the BT or ISO standards (the specification is optional);
- ◆ Battery spec.: CR2, 3.0V, 800 mAh x 1pc
- ◆ Probe sensing direction:  $\pm X, \pm Y, +Z$
- ◆ Probe sensing over-travel :  $X-Y \pm 15^\circ, Z +5\text{ mm}$
- ◆ The trigger force in Z direction: 600g
- ◆ Trigger force in X-Y surface ( standard probe ) : 65-130g
- ◆ Unidirectional repeatability:  $\leq 2\mu\text{m}$
- ◆ Input voltage is  $24\text{V} \pm 10\%$  DC and output load current is 50 mA.



# Measuring Tool

## 55270 TAS 3D-Taster SLIMplus



**Extreme Slim**



**Made in Germany**



### Features:

- ▶ Simple and precise zero setting with accuracy 0.01mm.
- ▶ Slim and attractive design reduce interfere with workpiece.
- ▶ Probing is possible in all axle directions (X/Y/Z) at the same indicator resolution. As soon as the indicator is at "0", the vertical axis is exactly on the edge of the work piece.
- ▶ Safe probe tips thanks to a bore hole for adjusting the probe tips with the help of the provided key

Standard Probe(Ceramic)



Long Probe(INOX)



Order No.	Model	Specification	Length	Diameter
55270-02	001V2D012	3D TASTER SLIMplus	Approx. 140	Ø12
55270-04	00163C003	Standard probe	27	Ø 3
55270-05	00163D006	Long probe	62	Ø 6



### 3D Protection system

The protection system consist of 4 devices

Device1:Thin neck of the probe breakage by the impact



Device2:Thick neck of the probe is hit by an external force and cause breakage.



Device3:Limit in X/Y



Device4:Limit in Z



# Measuring Tool

**55280**

**G**

**Precision Lever Indicator**



## Features :

- ▶ High sensitivity and accuracy.
- ▶ Anti-vibration and anti-magnetic design.
- ▶ Jeweled bearings isolated in a shock-proof assembly separately from the outer body and cannot be influenced by external pressure.
- ▶ Rugged anti-magnetic one-piece housing is satin chrome plated to resist corrosion.
- ▶ Adjustable ball bearings, provides ultra-smooth action.

## Applications:



※GIROD, swiss made.

Order No.	Model	Total Range	Dial Division	Dial diameter	Probe length	Force
55280-01	G1252	0.01	0.8	∅28	12	0.15N
55280-02	G1452	0.01	0.8	∅38	12	0.15N
55280-03	G1253	0.002	0.2	∅28	12	0.15N
55280-04	G1453	0.002	0.2	∅38	12	0.15N
55280-05	G1453SP	0.001	0.2	∅38	12	0.07N
55280-06	G1254	0.01	0.5	∅28	36	0.07N
55280-07	G1454	0.01	0.5	∅38	36	
55280-08	G1456	0.001	0.14	∅38	12	

**55282**

**M**

**Dial Indicator**

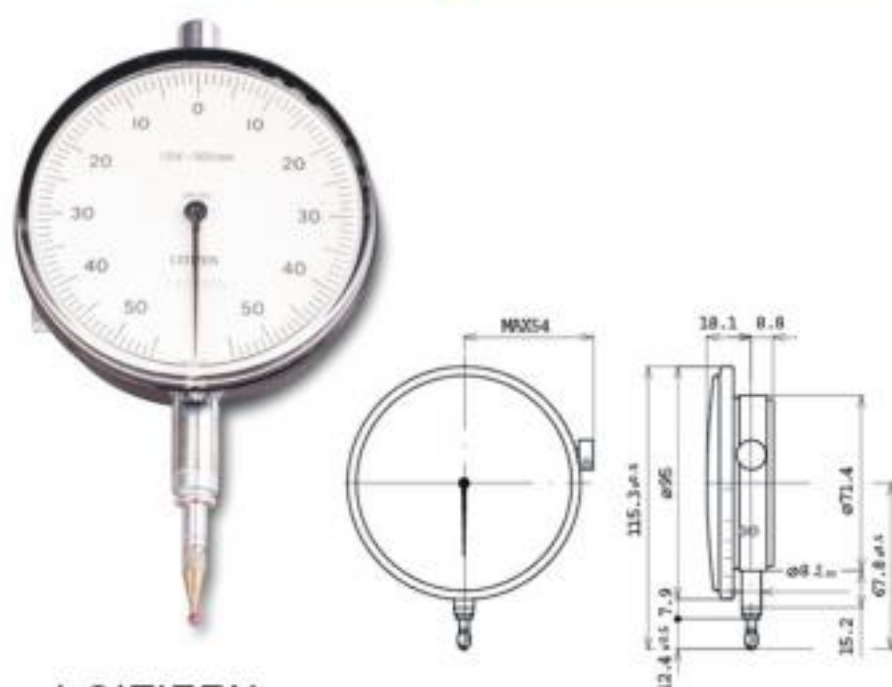

## Features :

- ▶ Large, high contrast dial face.
- ▶ High accuracy, high sensitivity and high stability are assured.
- ▶ Use of a buffer mechanism also assures excellent durability and impact resistance.

Brand:CITIZEN

Unit:mm

Order No.	Model	Graduation	Range	Accuracy	Measuring force	Stroke	Dial ∅
55282-01	2M100	1μm	±0.05	±1μm	0.784N	2.8mm	∅62
55282-02	3M100	1μm	±0.05	±1μm	0.588N	2.8mm	∅73
55282-03	3M250	2μm	0~1mm	±2μm	0.588N	2.8mm	∅73
55282-04	4M100P	0.5μm	±0.05	±0.5μm	0.588N	2.8mm	∅95

**55290** GCN Dial Comparators



**Features :**

- ▶ Large, high contrast dial face.
- ▶ Lockable fine adjustment screw and adjustable tolerance markers.
- ▶ Mounting shank and measuring spindle are both made of hardened stainless steel.
- ▶ Resistant to lateral forces (side play) acting on the measuring spindle and constant measuring force.
- ▶ Maximum sensitivity and accuracy are ensured by the jeweled movement in conjunction with the precision gears and pinions



Unit:mm

Order No.	Model	Range	Graduation	Dial reading	Brand
55290-01	GCN	±0.05	0.001	50-0-50	Mahr
55290-02	GCNA				ASIMETO

**55295** GCF Centering Indicators



**Features :**

- ▶ Provides a simplified method of centering a workpiece of fixture on horizontal for vertical machines, internal or external diameters.
- ▶ Operating speed not to exceed 800 RPM
- ▶ Graduation: 0.01mm
- ▶ Shank Dia.: Ø10mm
- ▶ Range: internal Ø4 to Ø300mm, external up to Ø300mm

Standard Accessories: : 6 pcs Feeler Set, Feeling Rod, Center Locating Feeler

Order No.	Description	Length	Max. Ø Measurable
55295-01	6 pcs Feeler Set		
55295-02	ID Feeler	50mm	100mm
55295-03	ID Feeler	100mm	200mm
55295-04	ID Feeler	150mm	300mm
55295-05	OD Feeler	50mm	100mm
55295-06	OD Feeler	100mm	200mm
55295-07	OD Feeler	150mm	300mm
55295-08	Center Locating Feeler		
55295-09	Feeling Rod		

ASIMETO Unit:mm

Order No.	Model	Accuracy	Dial Range
55295	GCF	0.005mm	0~3mm

# Measuring Tool

**55302**

GD

Digital Indicators

## Features:

- ▶ Robust construction.
- ▶ Water and coolant resistant.
- ▶ New technology with configurable menus.
- ▶ Broad choice of functions (MIN/MAX/DELTA, TOL, Factor, PRESET, AUTO OFF, etc.)
- ▶ Automatic wake-up and sleeping mode, Absolute System S.I.S\*

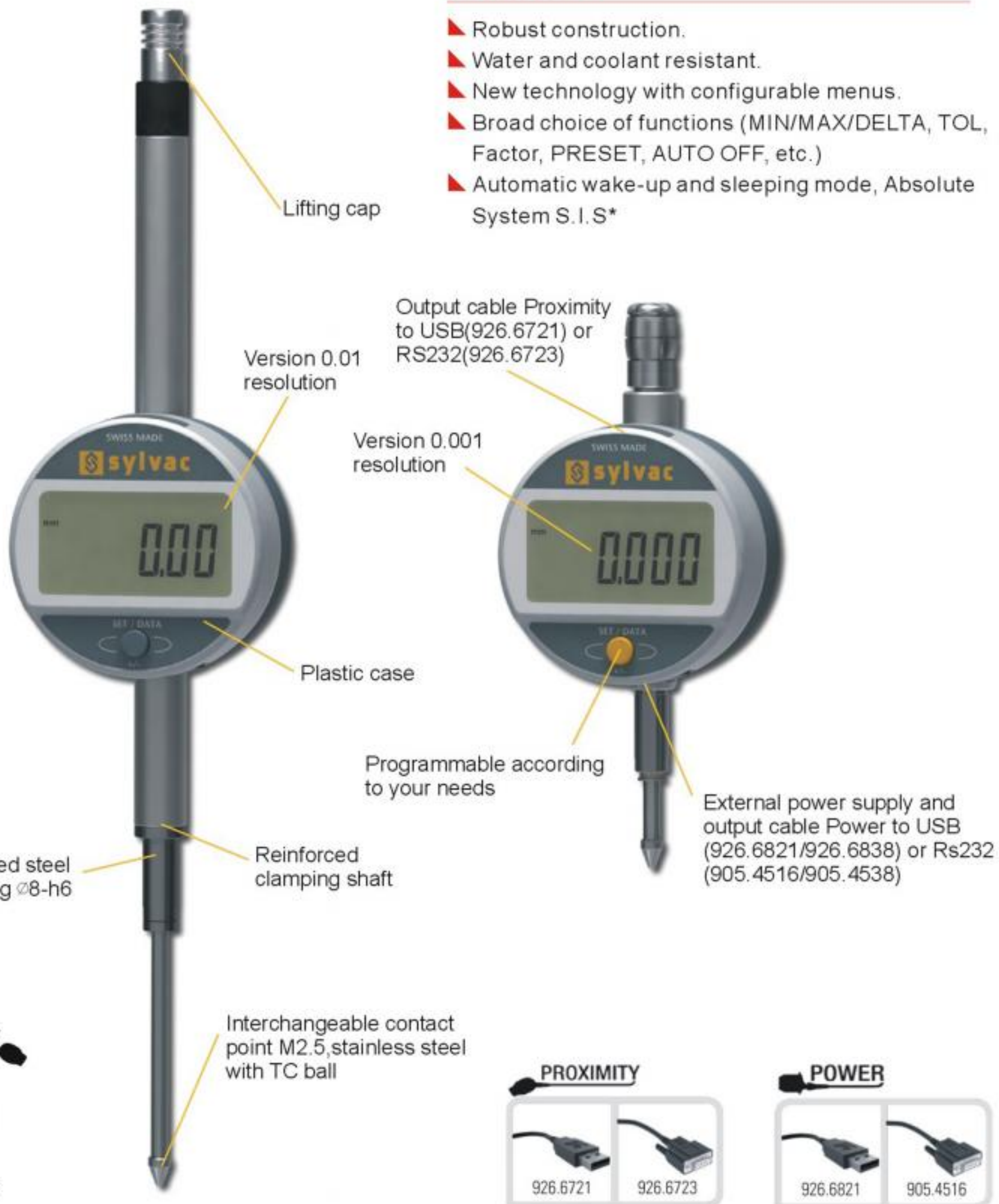

**SWISS MADE**

WATER RESISTANT

\* SIS description on page 5

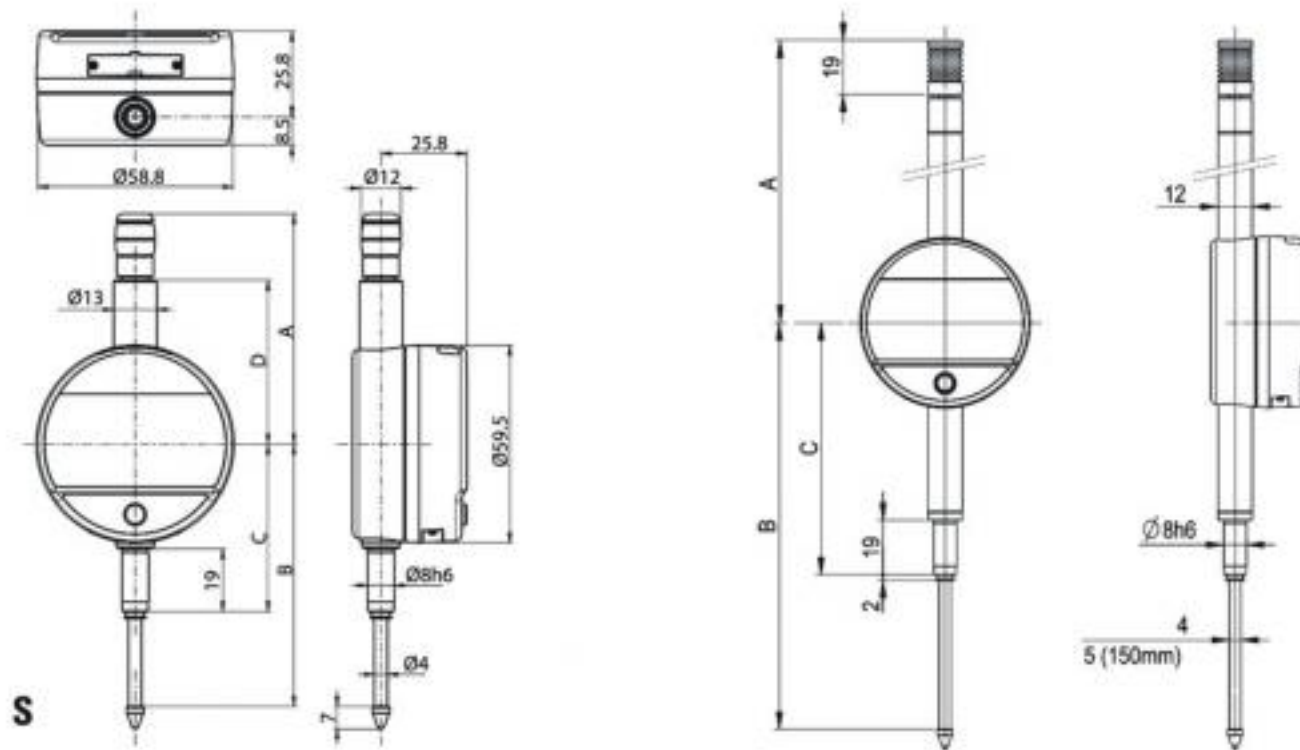

Order No.	55302-01	55302-02	55302-03	55302-04	55302-05	55302-06
Model	805.1201	805.1301	805.1401	805.1501	805.1601	805.1621
Measuring range mm	12.5	12.5	25	25	50	50
Resolution mm	0.01	0.001	0.01	0.001	0.01	0.001
Max. Error fe $\mu\text{m}$	10 <sup>1)</sup>	4	10 <sup>1)</sup>	5	20 <sup>1)</sup>	7
Repeatability $\mu\text{m}$	2					
IP rating	IP51					
A mm	56.7		69.9		121.3	
B mm	66.1		78.5		142	
C mm	50.5		50.5		88	
D mm	36.6		49.4		-	
Output data	USB / RS232					
Programmable by PC	●					
Standard functions (cystomized by PC)	Preset(only programmable by PC with cable) mm/inch,max 999.999),direction of measurement					

<sup>1)</sup>  $\pm 1$  digit

### BASIC INSTRUMENT

- Instrument according to technical specifications
- Linhium battery Cr2032 included
- Instruction manual
- Calibration certificate for instruments 0.001mm

### MEASURING FORCE

		S12.5	S25	S50
Standard	N	0.65-0.90	0.65-1.15	1.4-2.9
Low <sup>3)</sup>	N	0.4-0.55	0.45-0.9	---
High <sup>3)</sup>	N	1.0-1.6	0.9-1.8	---

Tolerance  $\pm 20\%$ , spindle in outgoing measurement position.  
<sup>3)</sup> on request

# Measuring Tool

**55305**

GD

Digital Indicators

## Features:

- ▶ Robust construction.
- ▶ Water and coolant resistant.
- ▶ New technology with configurable menus.
- ▶ Broad choice of functions (MIN/MAX/DELTA, TOL, Factor, PRESET, AUTO OFF, etc.)
- ▶ Automatic wake-up and sleeping mode, Absolute System S.I.S\*
- ▶ Maximum error of 3µm



Aluminium case rotating display over 270°

Reinforced clamping shaft

Hardened steel clamping Ø8-h6

Output cable Proximity to USB(926.6721) or RS232(926.6723)

Large display with integrated LEDs tolerances

Programmable according to your needs

Lifting cap

Optional lifter

External power supply and output cable Power to USB (926.6821/926.6838) or Rs232 (905.4516/905.4538)

Interchangeable contact point M2.5, stainless steel with TC ball

PROXIMITY

POWER

**SWISS MADE**

WATER RESISTANT

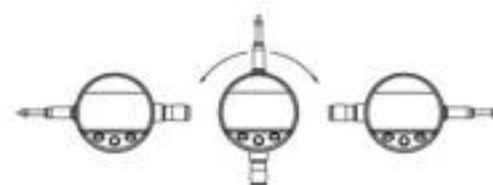

\* SIS description on page 5

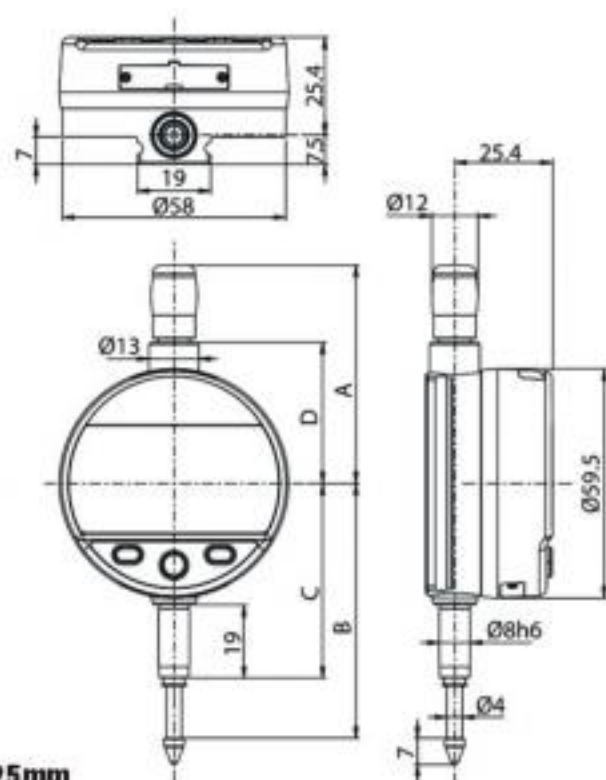
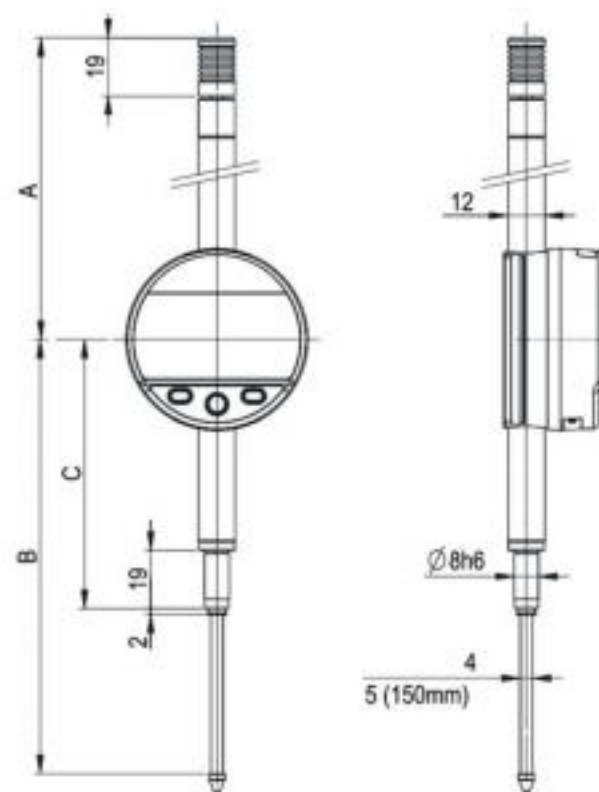
**S12.5-25mm**

**S50-150mm**

Order No.	55305-01	55305-02	55305-03	55305-04	55305-05	55305-06	55305-07	55305-08	55305-09	55305-10
Model	805.5201	805.5301	805.5401	805.5501	805.5601	805.5621	805.5641	805.5661	805.5671	805.5681
Measuring range	mm 12.5	mm 12.5	mm 25	mm 25	mm 50	mm 50	mm 100	mm 100	mm 150	mm 150
Resolution	mm 0.01	mm 0.001	mm 0.01	mm 0.001	mm 0.01	mm 0.001	mm 0.01	mm 0.001	mm 0.01	mm 0.001
Max. Error fe	μm 10 <sup>1)</sup>	μm 3	μm 10 <sup>1)</sup>	μm 4	μm 20 <sup>1)</sup>	μm 5	μm 20 <sup>1)</sup>	μm 6	μm 20 <sup>1)</sup>	μm 10
Repeatability	μm 2									
IP rating	IP54									
A	mm 56.7		mm 69.4		mm 121		mm 172		mm 224	
B	mm 66.1		mm 78.5		mm 142		mm 244		mm 349	
C	mm 50.5		mm 50.5		mm 88		mm 139		mm 193	
D	mm 36.6		mm 49.4		-		-		-	
Output data	USB / RS232									
Programmable by PC	●									
Standard functions (cystomized by PC)	Preset(only programmable by PC with cable) mm/inch,max 999.999),direction of measurement									

<sup>1)</sup> ± 1 digit

**BASIC INSTRUMENT**

- Instrument according to technical specifications
- Linhium battery Cr2032 included
- Instruction manual
- Calibration certificate for instruments 0.001mm

**MEASURING FORCE**

	12.5	25	50	100	150
Standard N	0.65-0.90	0.65-1.15	1.4-2.9	1.8-3.8	2.6-5.7
Low <sup>2)</sup> N	0.4-0.55	0.45-0.9	---	---	---
High <sup>2)</sup> N	1.0-1.6	0.9-1.8	---	---	---

Tolerance ± 20%, spindle in outgoing measurement position.

<sup>2)</sup> on request

# Measuring Tool

**55312**

GDC

Digital Calipers

## Features :

- ▶ Water protected for heavy-duty work with coolants and lubricants, protection rating IP67 according to IEC 60529, even connected
- ▶ Automatic wake-up by moving the electronic on his frame. (system S.I.S)
- ▶ Sleeping mode after 20min. of no use. (system S.I.S)
- ▶ Position memoriaed in sleeping mode (system S.I.S), absolute system\*
- ▶ Maximum speed of displacement: 2.5m/sec
- ▶ Mechanical frame in stainless steel, hardened and ground
- ▶ Thumb wheel on request (see accessories)
- ▶ Great comfort of use thanks to its ergonomic frame

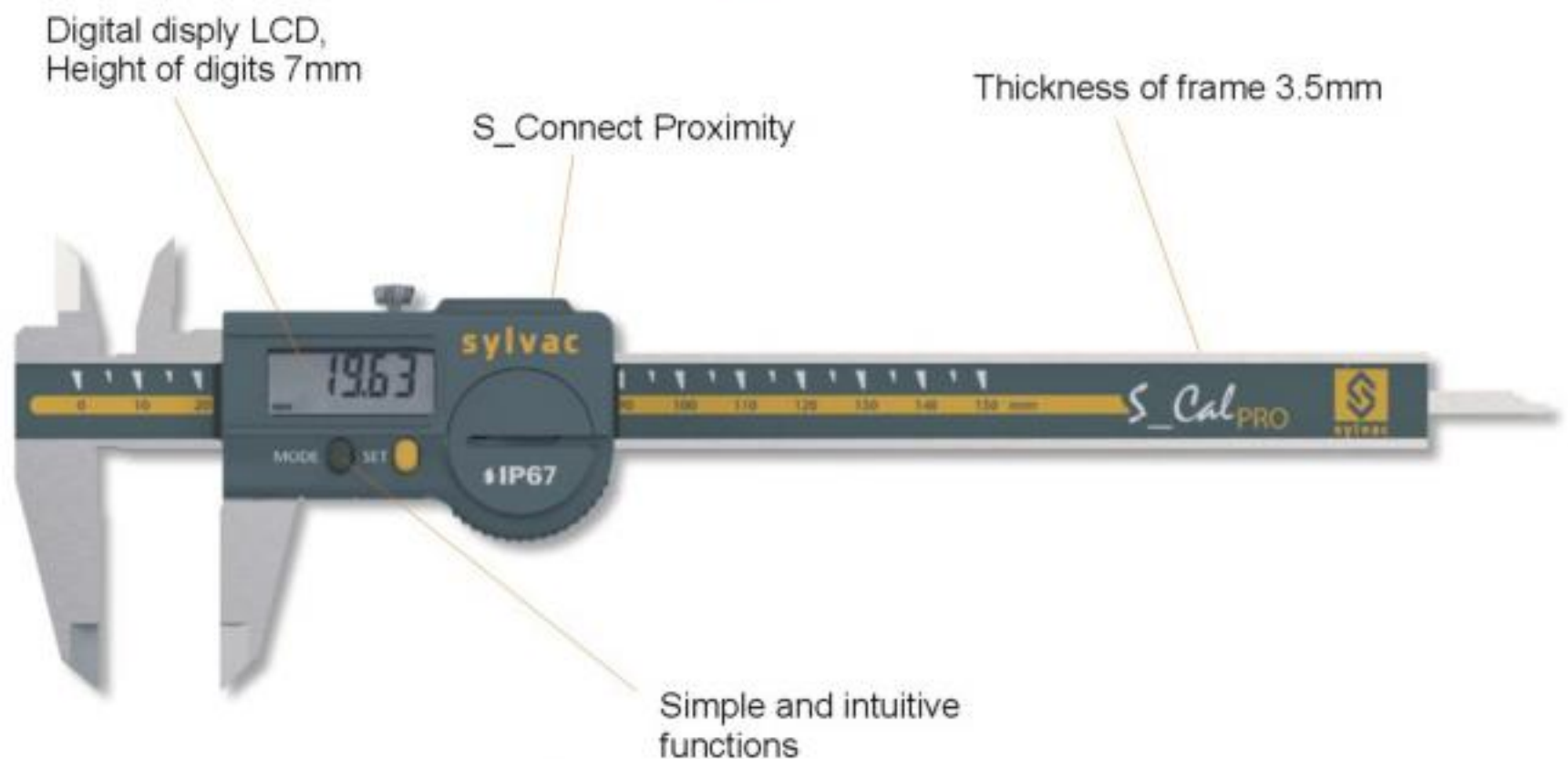

**SWISS MADE**

**SIS** Smart Inductive System

**WATER RESISTANT**

**IP67**

### PROXIMITY



\* SIS description on page 5



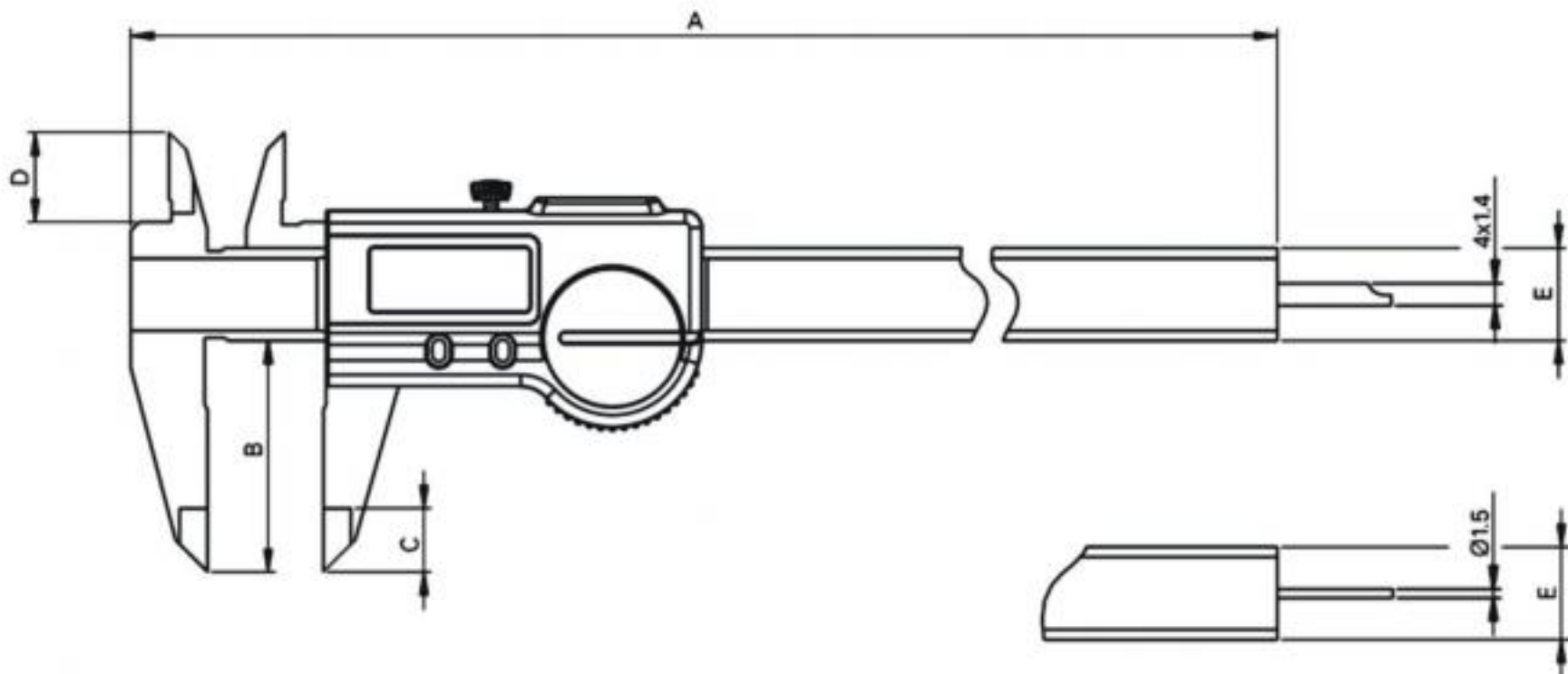

Unit:mm

Order No.	55312-01	55312-02	55312-03	55312-04
Model	910.1502	910.1507	910.1522	910.1532
Measuring range	150	150	200	300
Max.Error G	20 <sup>1)</sup>	20 <sup>1)</sup>	30	30
A	234.5	234.5	290.5	388
B	40	40	50	64
C	11	11	14	14
D	16	16	19	19
E	16x3.5	16x3.5	16x3.5	16x4
Depth rod	4x1.4	∅1.5	4x1.4	---
Protection rating according to IEC 60529	IP67 with or without connector			
S_Connect:Proximity	USB / RS232 / Wireless <sup>2)</sup>			
Zero setting	●			
Smart Inductive Sensor	●			

1) &gt;100mm:30μm / DIN862

2)see cables chapter

# Measuring Tool

**55335**

GDW

Outer Diameter Micrometers



## Features:

- ▶ Automatic wake-up by moving the measuring spindle (Absolute System S.I.S)
- ▶ Sleeping mode after 20 min. of no use (Absolute System S.I.S)
- ▶ Position memorized in sleeping mode, Absolute system S.I.S\*
- ▶ Water protected for heavy-duty work with coolants and lubricants, protection rating Ip67 according to IEC 60529, even connected
- ▶ Measuring range 0-161mm covered with 5 instruments only
- ▶ Set of 3 micrometers 0-102mm available
- ▶ Quick displacement of the measuring spindle 10mm/rotation
- ▶ Adjustable measuring force 5N/10N (versions 903.030X)
- ▶ Repeatability and reproducibility never reached before
- ▶ Thimble in polyacetal-copolymer

Measuring surface in hard metal

Non-rotating spindle  $\varnothing 6.5\text{mm}$



S\_connect proximity or Bluetooth®

Simple and friendly functions

**SWISS MADE**

**SIS** Smart Inductive System

WATER RESISTANT

PROXIMITY Built-in Bluetooth



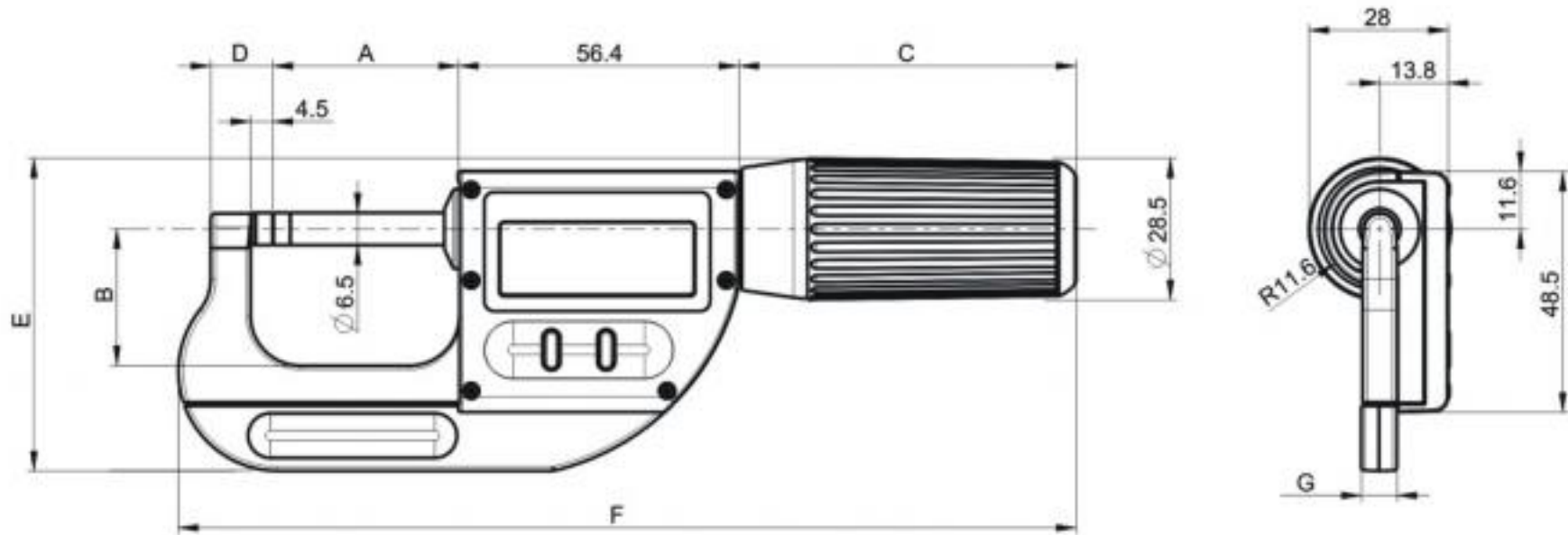

單位:mm

Order No.	55335-01	55335-02	55335-03	55335-04	55335-05	
Model	803.0300	903.0600	903.1000	903.1360	903.1600	
Measuring range	mm	0-30	30-66	66-102	100-136	125-161
Max.Error G <sup>1)</sup>	μm	3	4	5	7	8
Resolution <sup>2)</sup>	μm	1	1	1	2	2
Anvils types	∅6.5					
A	mm	37.3	73.3	109.3	143.3	168.3
B	mm	27.5	43	60	95	110
C	mm	68	74	74	74	74
D	mm	12.5	13.5	14.5	19.5	19.5
E	mm	63	86	106	151	169
F	mm	181	230	269	306	339
G	mm	7.2	9	9	9	9
S_Connect:Proximity	USB / RS 232 / Wireless <sup>3)</sup>					
Prot.rating accor.toIEC 60529	IP67 even connected					
Setting by PC	●					
Adjustable measuring force	5N/10N	10N				
Non-rotating spindle	●					
Fast movement	●					
Preset function	●					
Smart Inductive Sensor	●					

<sup>1)</sup>According to DIN 853

<sup>2)</sup>± 1 digit

<sup>3)</sup>see cables chapter

# Measuring Tool

**55345**

DHG

Digital Height Gauge

**SWISS  
MADE**

PROXIMITY

Built-in  
Bluetooth



POWER



## Features:

- ▶ Intuitive functions
- ▶ 400 and 600mm versions
- ▶ Robust mechanics
- ▶ Proximity, Power and Bluetooth® data outputs
- ▶ Metric / inch conversion
- ▶ First height measuring and scribing instrument with Bluetooth® wireless technology

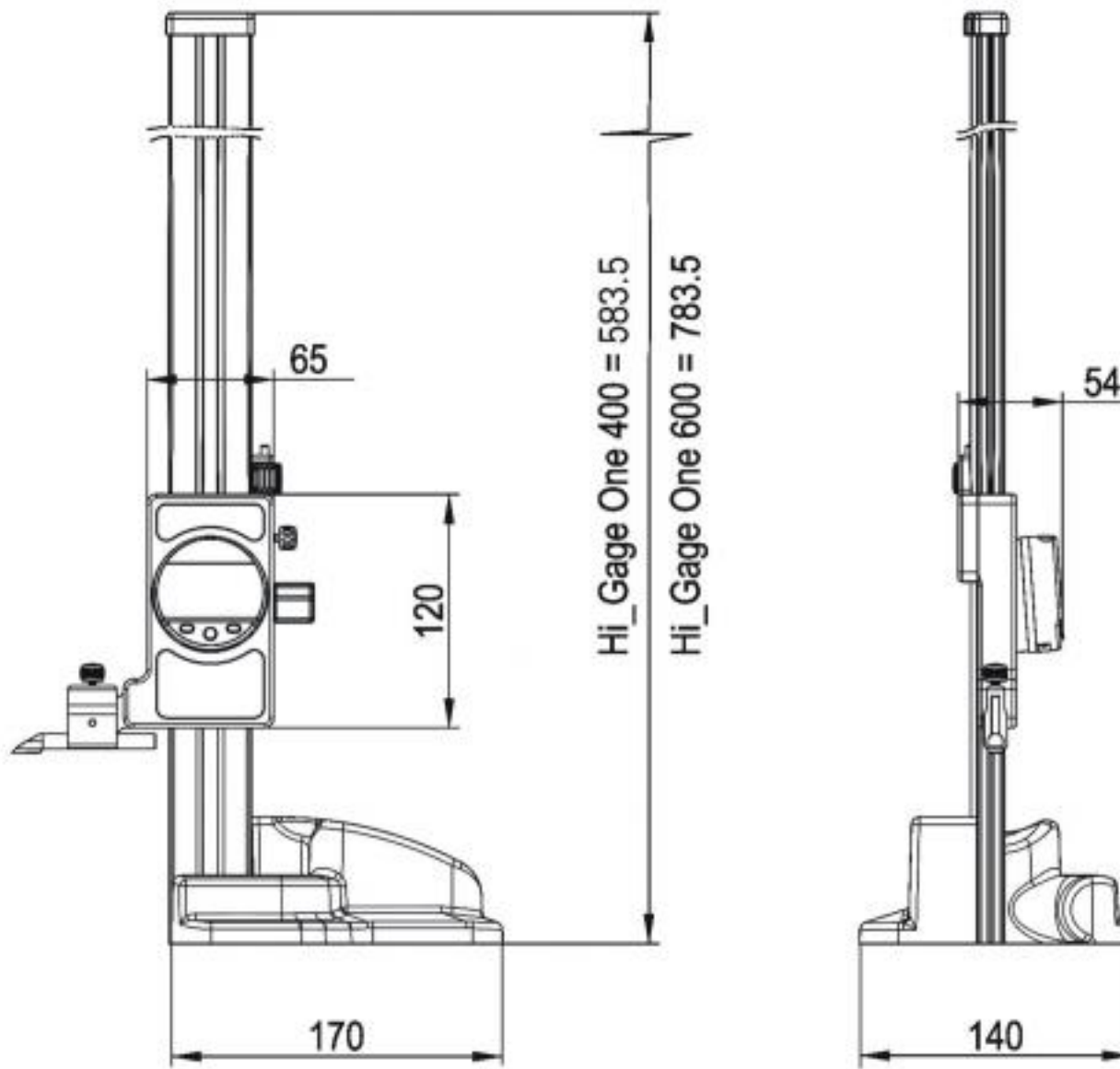

MEASURING TOOL

**55345**
**DHG**
**Digital Height Gauge**

單位:mm

Order No.	55345-01	55345-02
Model	840.0406	840.0606
Measurement range	400mm	600mm
Resolution	0.01mm	0.01mm
Max.error	40μm	50μm
Repeatability	10μm	10μm
2 references		●
PRESET		9999.99
Selection of measuring direction		●
Smart Inductive Sensor(S.I.S)		●
Output data	Bluetooth <sup>®</sup> wireless technology / RS232 / USB	

<sup>1)</sup> ± 1 digit

**Optional accessories**

Order No.	Model	Description
55345-07	840.9001	Ball probe Ø 8mm
55345-08	840.9002 <sup>1)</sup>	Tracing probe
55345-09	905.2247	Clamping stem Ø8mm

<sup>1)</sup> supplied in standard

840.9001



840.9002



905.2247

# Measuring Tool

## 55348 VT Squareness Tester

### Features :

- ▶ Suitable for placing on granite stone and measuring the squareness.
- ▶ Slide rail is made of alloy steel with HRC 65° and cryogenic treatment.
- ▶ The slide rail is almost free when applied in a constant temperature testing room or environment.

VT300

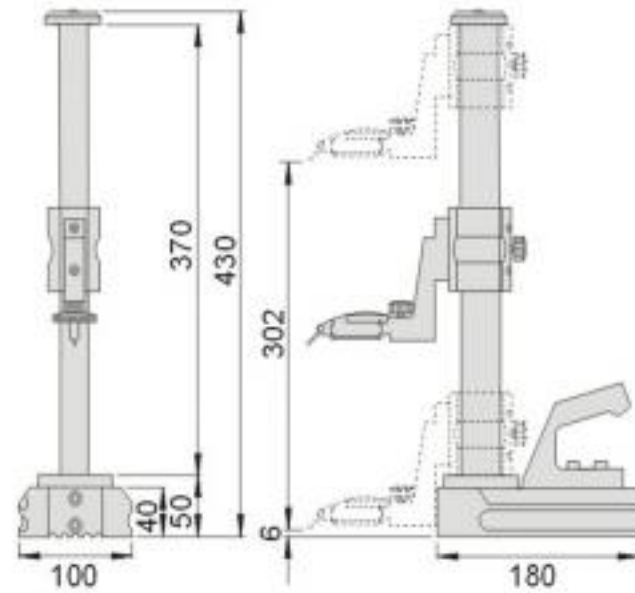

VT600

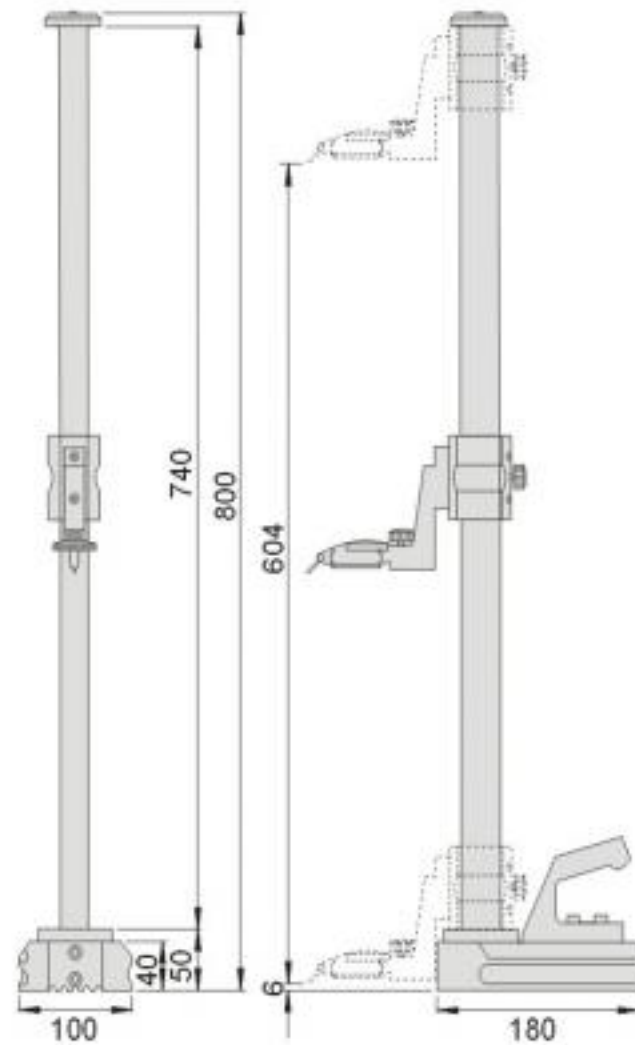

\*Lever indicator is not included.

Unit:mm

Order No.	Model	Measuring Range	Accuacy	N.W.
55348-30	VT300	300	0.003	8.5kgs
55348-60	VT600	600	0.005	12.8kgs

**55350** MH065 Micrometer Heads

**Features:**

► Suitable for fine-tuning and measuring precision instruments.

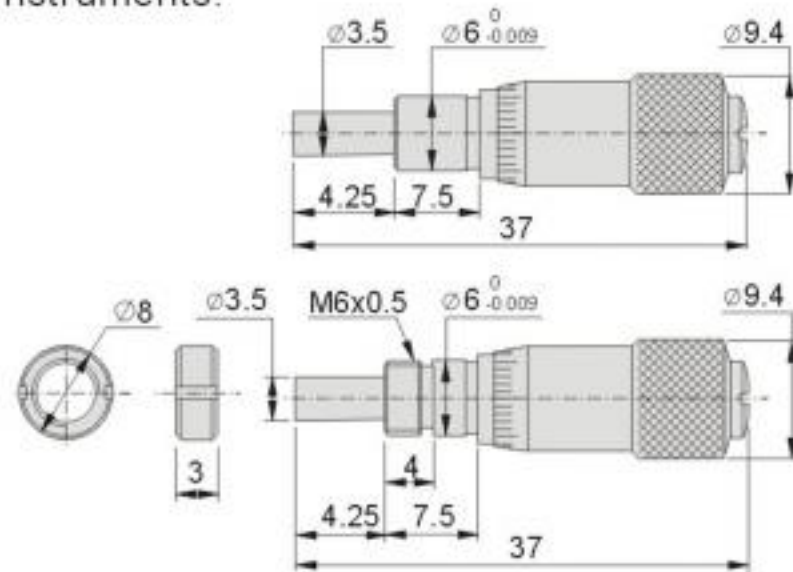
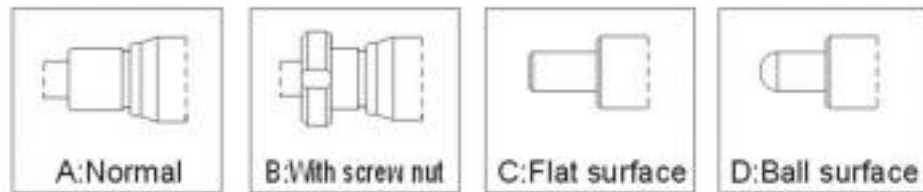

Unit:mm

Order No.	Model	Range	Accuracy	Reading	Remark
55350-01	MH065AC	0-6.5	0.005	0.01	A&C
55350-02	MH065AD				A&D
55350-03	MH065BC				B&C
55350-04	MH065BD				B&D

※Custom made is available

**55355** MH130 Micrometer Heads

**Features:**

► Suitable for fine-tuning and measuring precision instruments.

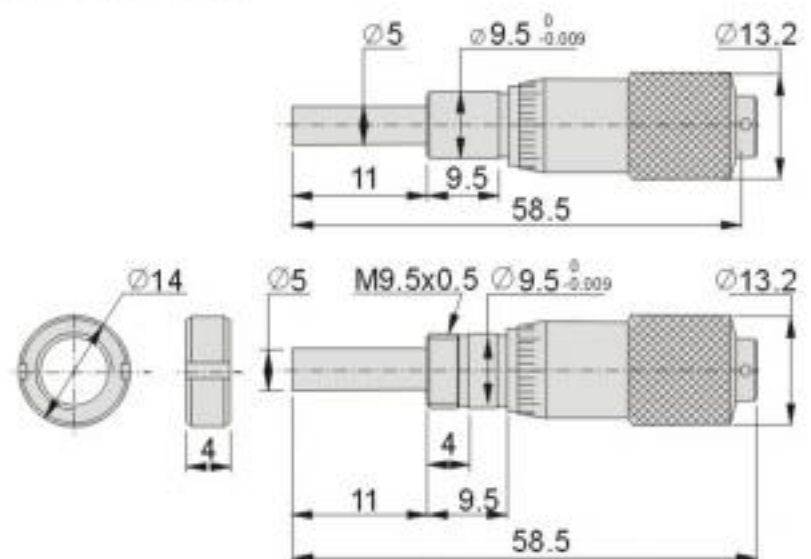
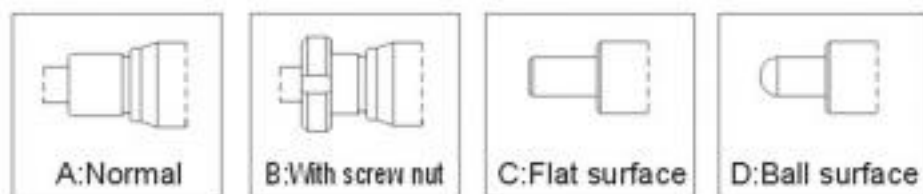

Unit:mm

Order No.	Model	Range	Accuracy	Reading	Remark
55355-01	MH130AC	0-13	0.005	0.01	A&C
55355-02	MH130AD				A&D
55355-03	MH130BC				B&C
55355-04	MH130BD				B&D

※Custom made is available

## Measuring Tool

55400/05

PGCA

Concentricity Measuring Instrument



55400  
PGCA

N.W. 4.3kg



55405  
PGCA-1

N.W. 5.0kg

### Features :

- ▶ Suitable for application on measuring concentricity with high accuracy result.
- ▶ Commonly utilised in cutting tools, press die, semi-conductor, automotive & aviation industry
- ▶ Cost effective & high efficiency
- ▶ Base is made of tool steel with salt bathing nitriding, high rust resistance.

### Main parameters:

Range:  $\varnothing 3.0\text{mm} \sim \varnothing 25\text{mm}$

Length: within 100mm.

Accuracy: 0.002mm

Size: 267mm x 114mm x 125mm

### Accessory:

Lever indicator 

Universal arm

55410/15

PGCB

Concentricity Measuring Instrument



55410  
PGCB

N.W. 4.28kg



55415  
PGCB-1

N.W. 5.0kg

### Features :

- ▶ Suitable for application on measuring concentricity with high accuracy result.
- ▶ Commonly utilised in cutting tools, press die, semi-conductor, automotive & aviation industry
- ▶ Cost effective & high efficiency
- ▶ Base is made of tool steel with salt bathing nitriding, high rust resistance.

### Main parameters:

Range:  $\varnothing 0.5\text{mm} \sim \varnothing 25\text{mm}$

Length: within 100mm.

Accuracy: 0.002mm

Size: 267mm x 114mm x 125mm

### Accessory:

Lever indicator 

Universal arm



**55430/35**
**PGCD**
**Concentricity Measuring Instrument**

 55430  
PGCD

N.W. 4.24kg

### Features :

- ▶ Suitable for application on measuring concentricity with high accuracy result.
- ▶ Commonly utilised in cutting tools, press die, semi-conductor, automotive & aviation industry
- ▶ Cost effective & high efficiency
- ▶ Base is made of tool steel with salt bathing nitriding, high rust resistance.

### Main parameters:

Range:  $\varnothing 0.5\text{mm} \sim \varnothing 25\text{mm}$   
 Length: within 100mm.  
 Accuracy: 0.002mm  
 Size: 267mm x 114mm x 125mm

### Accessory:

Lever indicator   
 Universal arm

 55435  
PGCD-1

N.W. 4.85kg

**55440**
**PGCE**
**Concentricity Measuring Instrument**

N.W. 5.5kg

### Features :

- ▶ Suitable for measuring concentricity, roundness and deviation with high precision.
- ▶ Commonly used in cutting tool, press die, semi-conductor, aviation and automobile industries.
- ▶ Cost effective and efficiency.

### Main parameters:

Range:  $\varnothing 0.5\text{mm} \sim \varnothing 25\text{mm}$   
 Length: within 100mm.  
 Accuracy: 0.002mm  
 Size: 267mm x 114mm x 125mm

### Optional accessory:

Lever indicator 

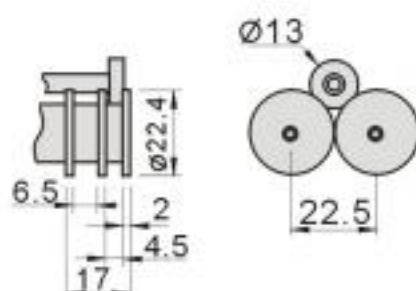

# Measuring Tool

## 55441 PGCF Concentricity Measuring Instrument



### Features:

- ▶ Special design for cylindrical grinding long workpiece with  $\varnothing 1 \sim \varnothing 10\text{mm}$  outer circle as well as end face.
- ▶ For measuring concentricity purpose, it can measure from  $\varnothing 0.5$  to  $\varnothing 25\text{mm}$  with accuracy  $0.003\text{mm}$

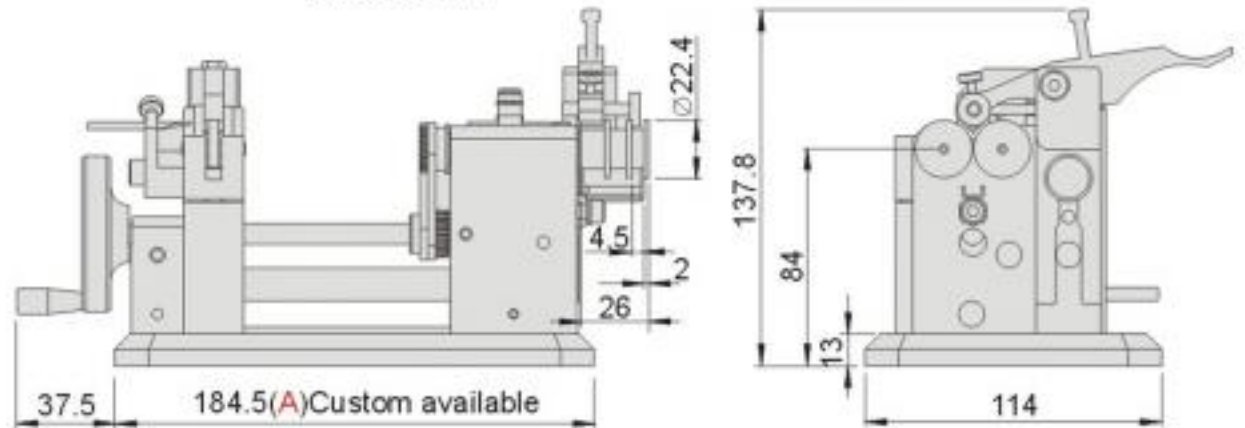

## 55442 PGCG Concentricity Measuring Instrument



### Features:

- ▶ Capable of holding from  $\varnothing 1 \times 15\text{L}$  to  $\varnothing 25 \times 80\text{L}$ .
- ▶ Compact design and suitable for placed on granite stone for testing run-out. Accuracy within  $0.002\text{mm}$ .
- ▶ Slot on the bottom for fixing on jig or fixture.

N.W. 2.5kg

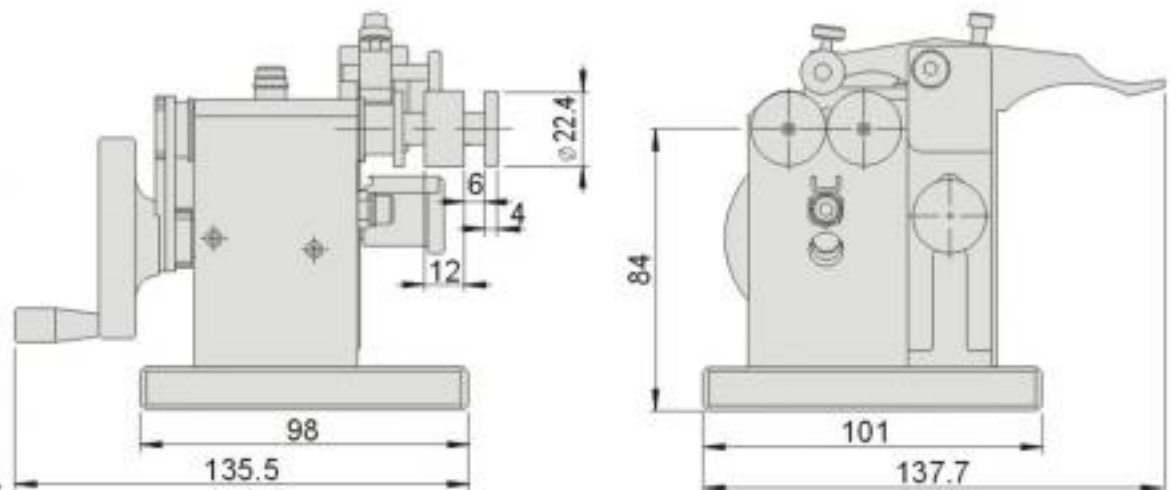

Example:

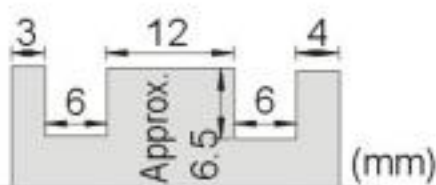

MEASURING TOOL

**55443** PGCH Concentricity Measuring Instrument



N.W. 4.1kg

Optional long base version for placing other dial indicators.



**Features:**

- ▶ Capable of holding  $\varnothing 4\sim\varnothing 25\text{mm}$ , length  $5\sim 80\text{mm}$ .
- ▶ Suitable for placed on granite stone for testing run-out. Accuracy within  $0.002\text{mm}$ .
- ▶ Dual axis slider design for stability and ideal testing position.

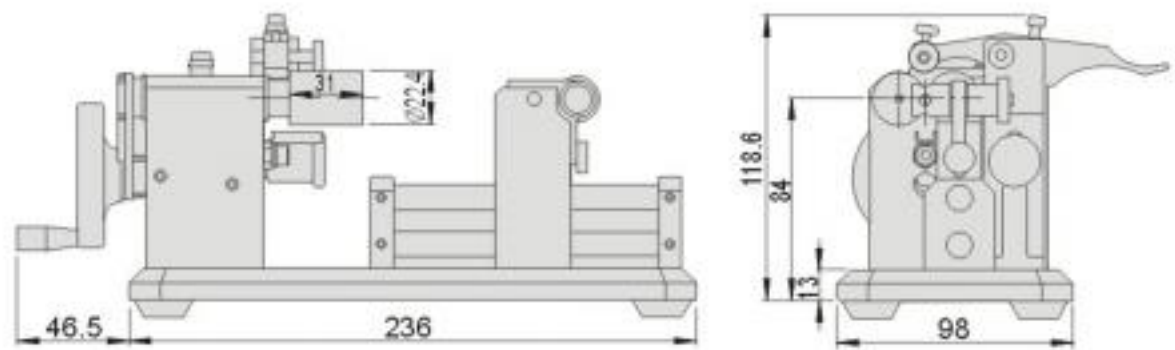

**Applications:**



**55445** PGCI Concentricity Measuring Instrument



N.W. 5.3kg

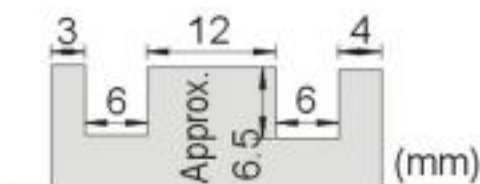

**Features:**

- ▶ Capable of holding  $\varnothing 4\sim\varnothing 25\text{mm}$ , length  $5\sim 80\text{mm}$ .
- ▶ Suitable for placed on granite stone for testing run-out. Accuracy within  $0.002\text{mm}$ .
- ▶ Linear rail design for stability and ideal testing position.

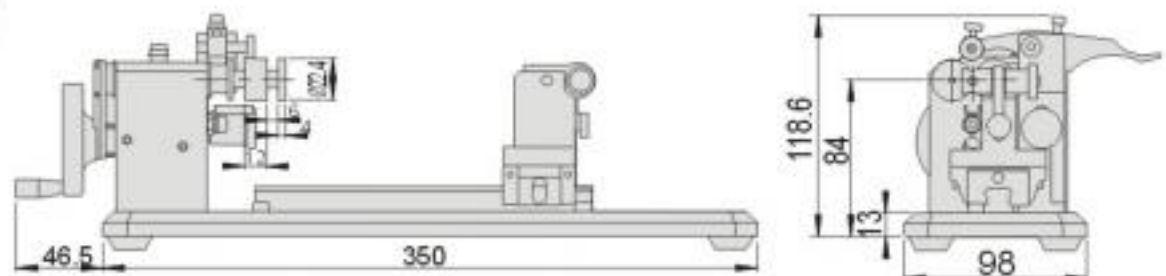

**Applications:(testing I.D & O.D.)( I.D & End face)**



# Measuring Tool

**55446**

PGCJ

Concentricity Measuring Instrument

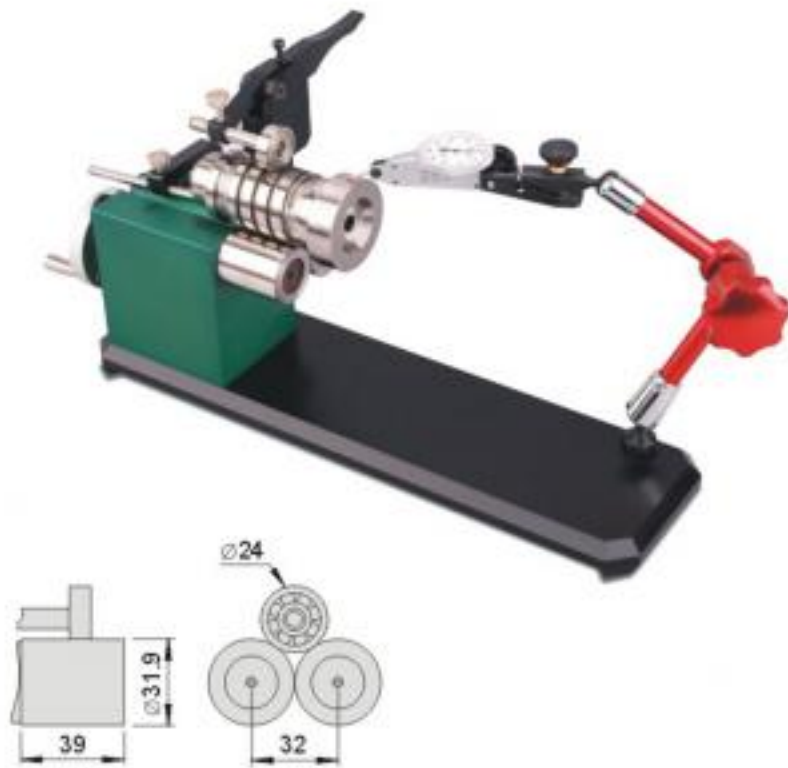

## Features :

- ▶ Capable of holding larger diameter.
- ▶ Suitable for testing run-out, end face center and accuracy within 0.002mm.
- ▶ Lever indicator & universal arm are excluded.

## Main parameters:

Range:  $\varnothing 4.0\text{mm} \sim \varnothing 40\text{mm}$

Length: 130mm(guaranteed)  
300mm(to the end)

Accuracy: 0.002mm

Size: 172mm x 200mm x 389.5mm

## Optional accessory:

Lever indicator 

Universal arm

**55448**

PHCR

Eccentric Checking Instrument



## Features :

- ▶ With fine-tuning function for X, Y & Z axis, positioning is easier and realise O.D. and end face testing.
- ▶ Lever indicator are excluded.

## Main parameters:

Range:  $\varnothing 4.0\text{mm} \sim \varnothing 40\text{mm}$

Length: 130mm(guaranteed)  
280mm(to the end)

Accuracy: 0.002mm

Size: 182mm x 370mm x 486mm

## Optional accessory:

Lever indicator 

Universal arm

MEASURING TOOL



Fine-tuning knob for Z axis



O.D. & End face testing



Fix knob for X axis



Fine-tuning knob for X & Y axis

**55450**
**HCR1**
**Eccentric Checking Instrument**

Center Slider type

**Features :**

- ▶ Sophisticated design with high accuracy and simple operation.
- ▶ Casting iron with surface treatment and ground ensuring the durability.
- ▶ Widely used for deviation, roundness, eccentric checking.
- ▶ Slider design with special modulisation can ensure repeating accuracy.
- ▶ Optional spec. for HCR1-400 with H:325mm and choice of center height of 200mm or 300mm.

Attention: Dial indicator &amp; standard rod are optional accessories.

Unit:mm

Order No.	Model	Length	Width	Height	Center Height	Center Length	Mobile Accuracy	N.W.	Live Center
55450-01	HCR1-100	245	80	88	45	100	0.005	13kg	MT1
55450-02	HCR1-200	490	160	175	90	200	0.005	25kg	MT1
55450-03	HCR1-300	590	182	175	90	300	0.01	29kg	MT1
55450-04	HCR1-400	730	205	242	130	400	0.01	62kg	MT2

**55460**
**HCR2**
**Eccentric Checking Instrument**

Wheel Slider type

**Features :**

- ▶ Sophisticated design with high accuracy and simple operation.
- ▶ Casting iron with surface treatment and ground ensuring the durability.
- ▶ Widely used for deviation, roundness, eccentric checking.
- ▶ Slider design with special modulisation can ensure repeating accuracy.
- ▶ Optional spec. for HCR2-400 with H:325mm and choice of center height of 200mm or 300mm.

Attention: Dial indicator &amp; standard rod are optional accessories.

Unit:mm

Order No.	Model	Length	Width	Height	Center Height	Center Length	Mobile Accuracy	N.W.
55460-01	HCR2-300	590	182	175	90	300	0.01	28kg
55460-02	HCR2-400	730	205	245	130	400	0.01	46kg

# Measuring Tool

## 55480 PM Precision Comparator Stands

**PMSTA**  
Standard type



**PMCEB**  
Fine-tuning type



### Features :

- ▶ Compact and sturdy design with slick look and ultra-precision assembly parts.
- ▶ With fine-tuning function, easy to set zero.
- ▶ Especially for measurement of comparatively small parts.
- ▶ The column is precisely ground, hardened and plating.
- ▶ The table is precisely ground, hardened and polished in order to ensure the accuracy.
- ▶ The stand can be turn 180° and applied on large surface granite for measuring larger workpiece's flatness.
- ▶ Standard type is suitable for digital dial indicator\*.
- ▶ Fine-tuning type is suitable for dial indicator\*.

### Main parameters:

Vertical stroke ..... 130mm  
 Column diameter.....  $\varnothing 25$ mm  
 Table diameter.....  $\varnothing 60$ mm  
 Flatness ..... 0.001mm

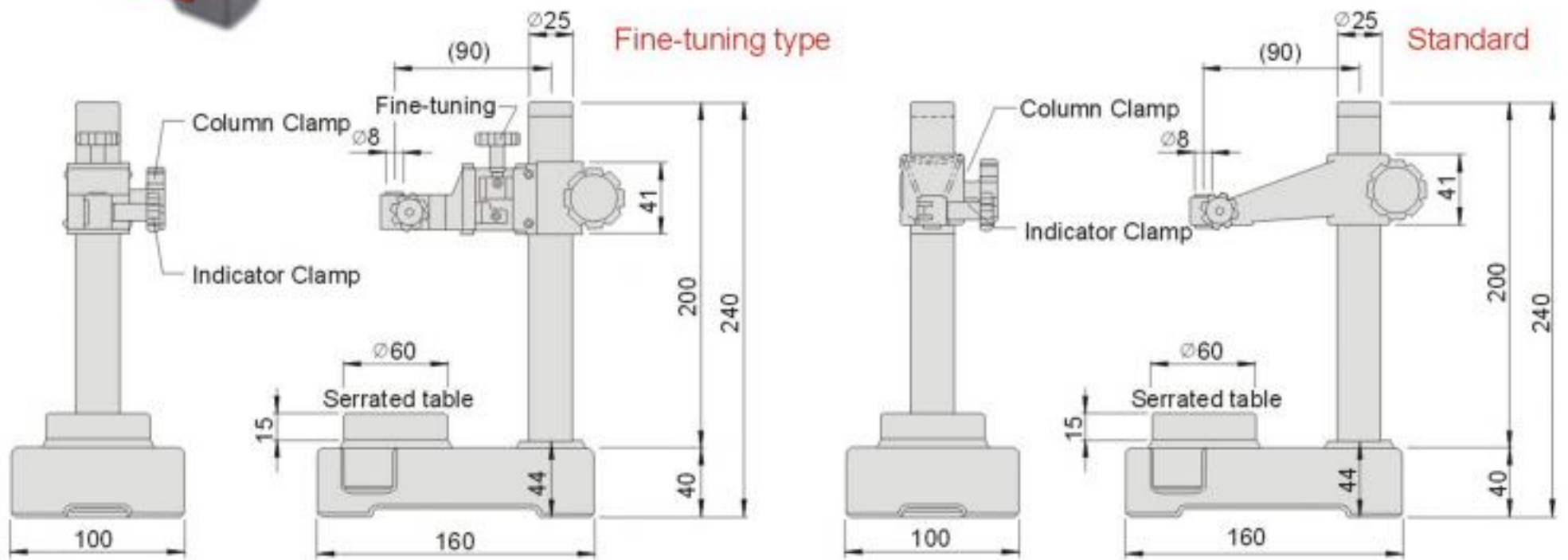

\*Dial indicator is not included

Unit:mm

Order No.	Model	Stand Base			Table	Column		Indicator clamping
		L	W	H		Diameter	Length	
55480-ST-A	PMSTA	160	100	40	SKD11 Steel	$\varnothing 25$	200	8mm
55480-ST-B	PMSTB							
55480-CE-A	PMCEA				Ceramic			
55480-CE-B	PMCEB							

**PMSTC**

Steel base

**Features :**

- ▶ Compact and sturdy design with slick look and ultra-precision assembly parts.
- ▶ Especially for measurement of comparatively small parts.
- ▶ The column is precisely ground, hardened and plating.
- ▶ The table is precisely ground, hardened and polished in order to ensure the accuracy.
- ▶ The stand can be turn 180° and applied on large surface granite for measuring larger workpiece's flatness.
- ▶ Standard type is suitable for digital dial indicator\*.

**Main parameters:**

Vertical stroke ..... 240mm  
 Column diameter.....  $\varnothing 30$ mm  
 Table diameterter ..... 120.5 x 110.5mm  
 Flatness ..... 0.001mm

**PMCEC**

Ceramic table

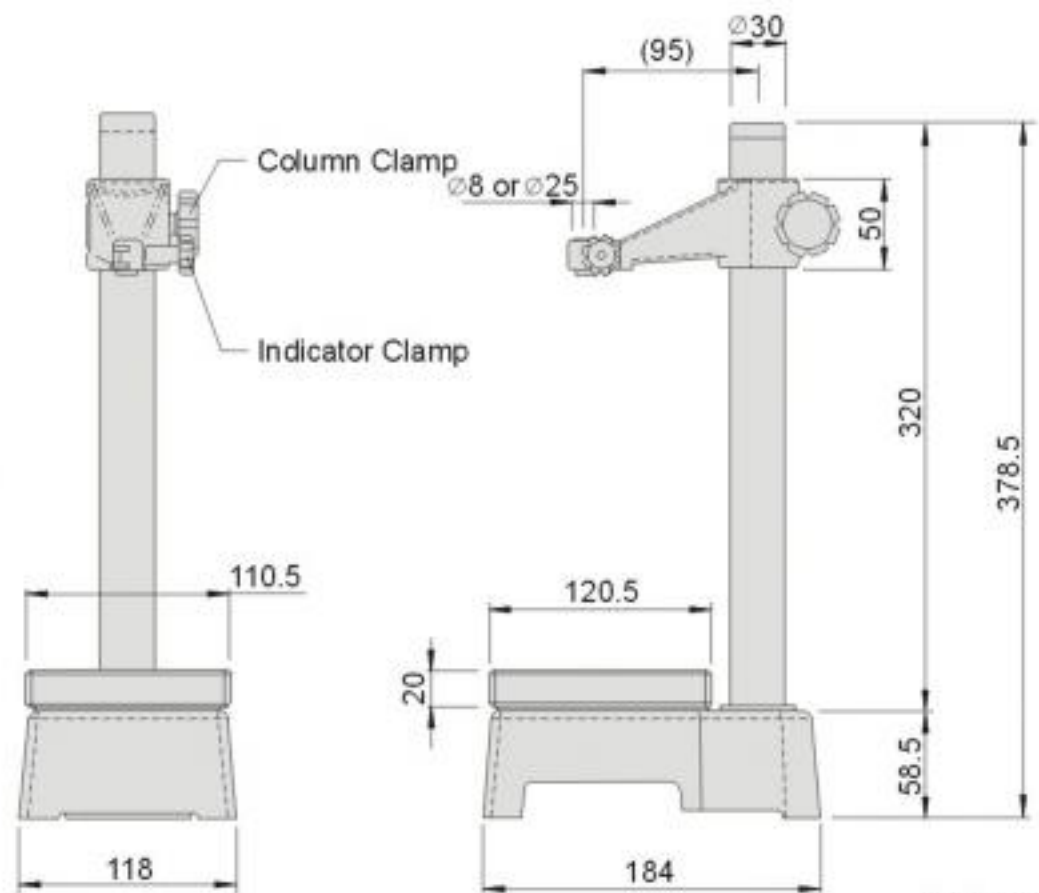

Unit:mm

\*Dial indicator is not included

Order No.	Model	Stand Base			Table	Column		Indicator clamping
		L	W	H		Diameter	Length	
55485-ST-C	PMSTC	184	118	58.5	SKD11 Steel	$\varnothing 30$	320	8mm
55485-ST-D	PMSTD							25mm
55485-CE-C	PMCEC				Ceramic			8mm
55485-CE-D	PMCED							25mm

# Measuring Tool

**55490**

PMA

Precision Comparator Stands

**PMA200B**

Fine-tuning type



**PMA350C**

Standard type



**PMA350D**

Standard type



**Features :**

- ▶ Compact and sturdy design with slick look and ultra-precision assembly parts.
- ▶ With fine-tuning function, easy to set zero. Especially for measurement of comparatively small parts.
- ▶ The column is precisely ground, hardened and plating.
- ▶ The base is made of black granite that stays free of burrs and build-ups due to its fine-grain composition and easy to maintain and rusty free. The stand can be turn 180° and applied on large surface granite for measuring larger workpiece's flatness.
- ▶ Standard type is suitable for digital dial indicator\*. Fine-tuning type is suitable for dial indicator\*.

**Main parameters:**

Vertical stroke (B).....160mm  
 (C & D)..... 290mm  
 Column diameter (B).....  $\varnothing$  25mm  
 (C & D) .....  $\varnothing$  30mm  
 Flatness ..... 0.001mm

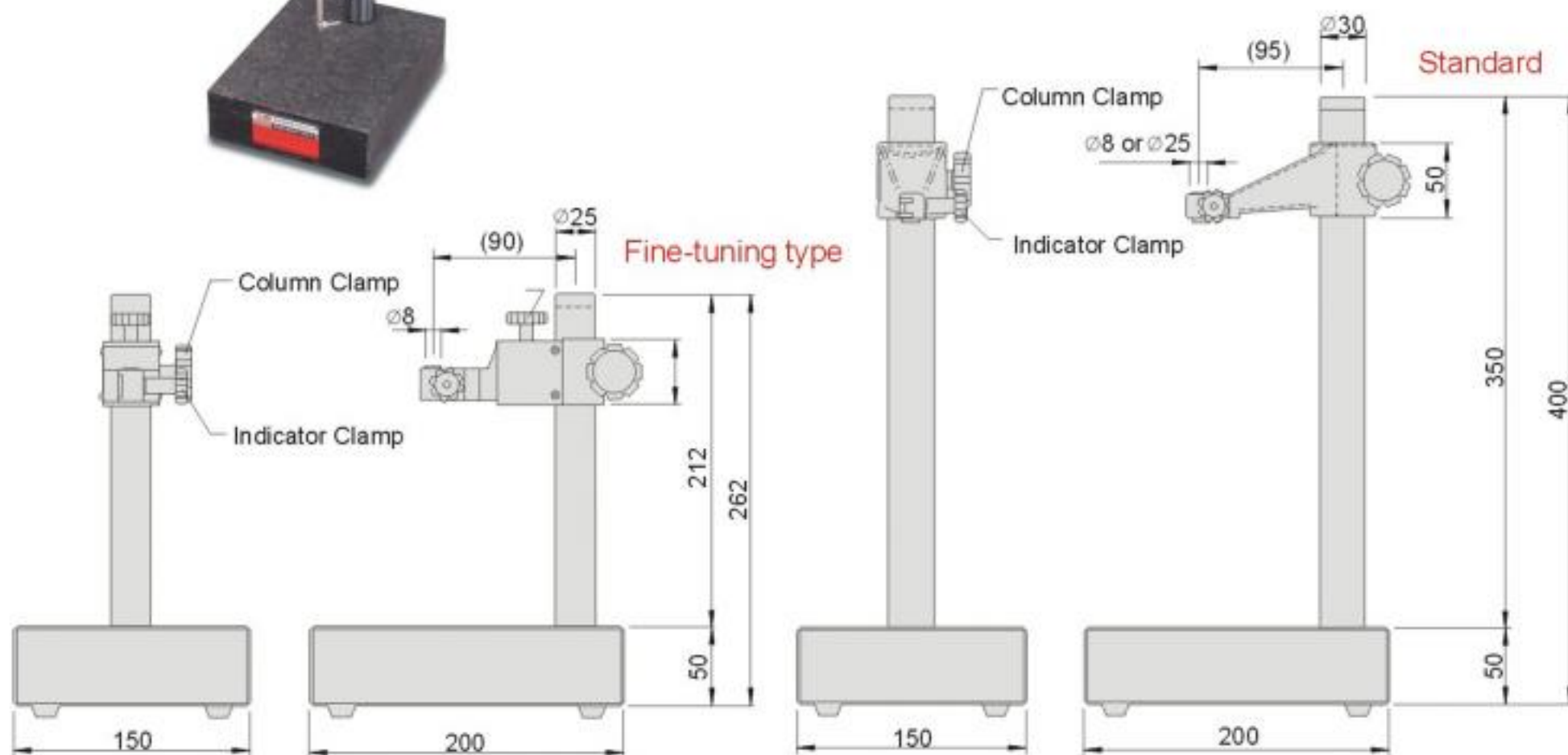

\*Dial indicator is not included

Unit:mm

Order No.	Model	Black Granite Base			Column		Indicator clamping
		L	W	H	Diameter	Length	
55490-200-B	PMA200B	200	150	50	$\varnothing$ 25	212	8mm
55490-350-C	PMA350C				$\varnothing$ 30	350	8mm
55490-350-D	PMA350D						25mm



**55495** PMB Precision Comparator Stands

**PM600C**  
Standard type



**PM600D**  
Standard type



**Features :**

- ▶ Compact and sturdy design with slick look and ultra-precision assembly parts.
- ▶ With fine-tuning function, easy to set zero.
- ▶ Especially for measurement of comparatively small parts.
- ▶ The column is precisely ground, hardened and plating.
- ▶ The base is made of black granite that stays free of burrs and build-ups due to its fine-grain composition and easy to maintain and rusty free.
- ▶ The stand can be turn 180° and applied on large surface granite for measuring larger workpiece's flatness.
- ▶ Standard type is suitable for digital dial indicator\*.

**Main parameters:**

Vertical stroke ..... 540mm  
 Column diameter.....  $\varnothing 30$ mm  
 Flatness..... 0.001mm

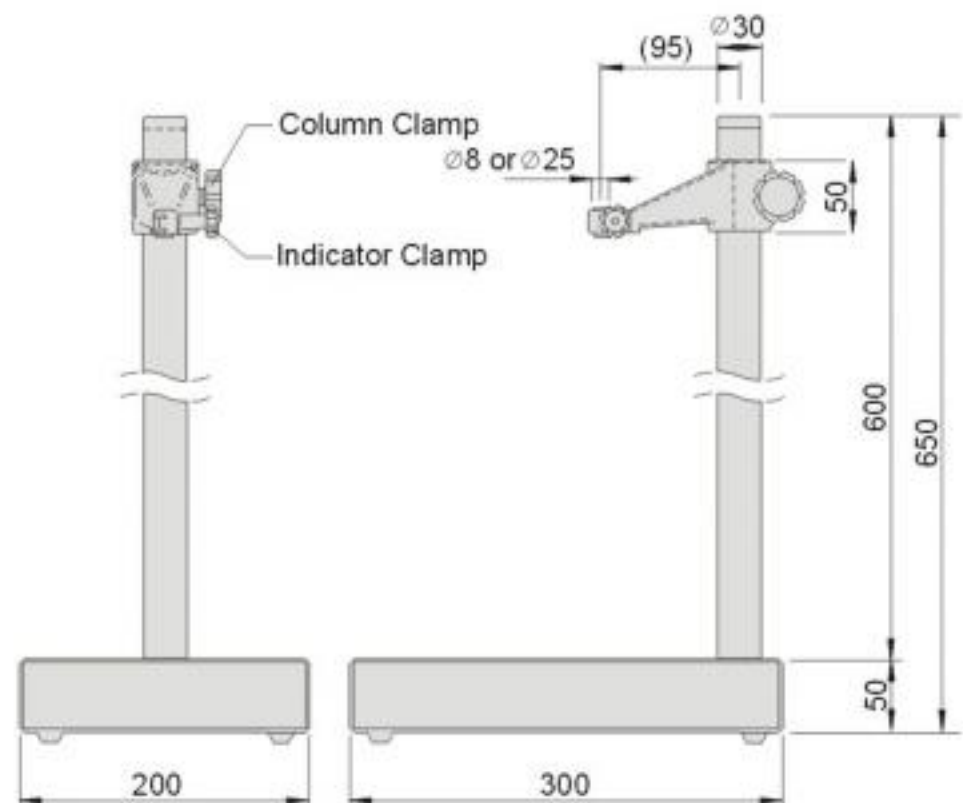

\*Dial indicator is not included

Unit:mm

Order No.	Model	Black Granite Base			Column		Indicator clamping
		L	W	H	Diameter	Length	
55495-600-C	PMB600C	300	200	50	$\varnothing 30$	600	8mm
55495-600-D	PMB600D						25mm

# Measuring Tool

**55600**

FCMM

Fixtures for Coordinate Measuring Machine

PAT. M387241

FCMM can be used to secure any sized part to ensure consistent and accurate CMM inspection. When securing workpieces, it is vital to select suitable clamps and use them correctly to avoid any part damage or distortion.

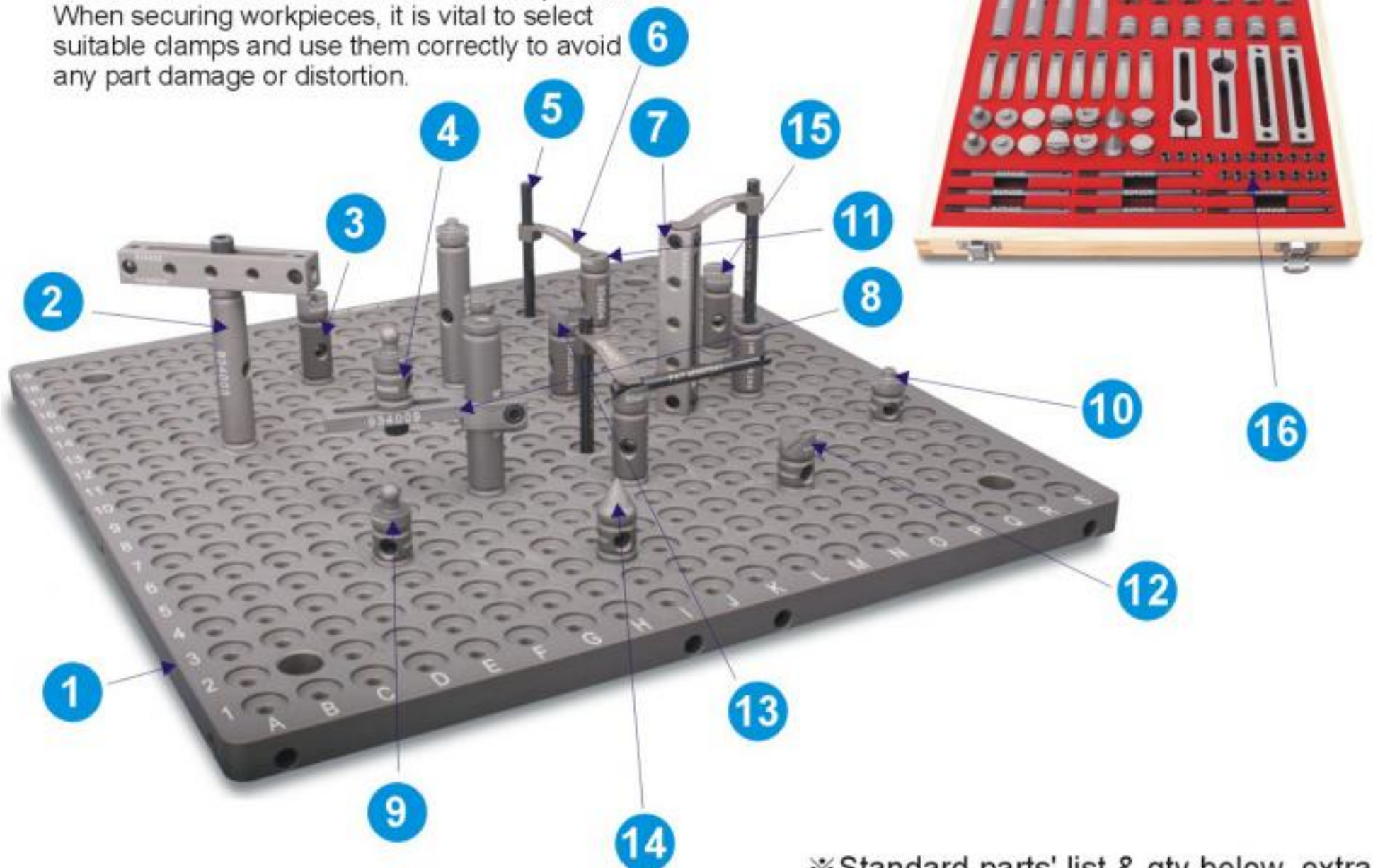

※Standard parts' list & qty below, extra order will be sold in single piece.

	Order No.	Model	Spec.	Q'ty		Order No.	Model	Spec.	Q'ty
1	55600-01	934001	20x500x500	1	9	55600-09	934010	∅20x28.5	3
2	55600-02	934003	∅20x100	4	10	55600-10	934011	∅20x20	3
3	55600-03	934004	∅20x50	6	11	55600-11	934012	∅20x15	3
4	55600-04	934005	∅20x25	6	12	55600-12	934013	∅20x20	3
5	55600-05	934006	∅8x100	8	13	55600-13	934014	∅20x20	2
6	55600-06	934007	11x12x65	8	14	55600-14	934015	∅20x28.5	3
7	55600-07	934008	20x20x114	2	15	55600-15	934016	∅20x20	2
8	55600-08	934009	15x26x106	2	16	55600-16	A01085	M8x1.25x20L	20

MEASURING TOOL

**55600** FCMM > Fixtures for Coordinate Measuring Machine

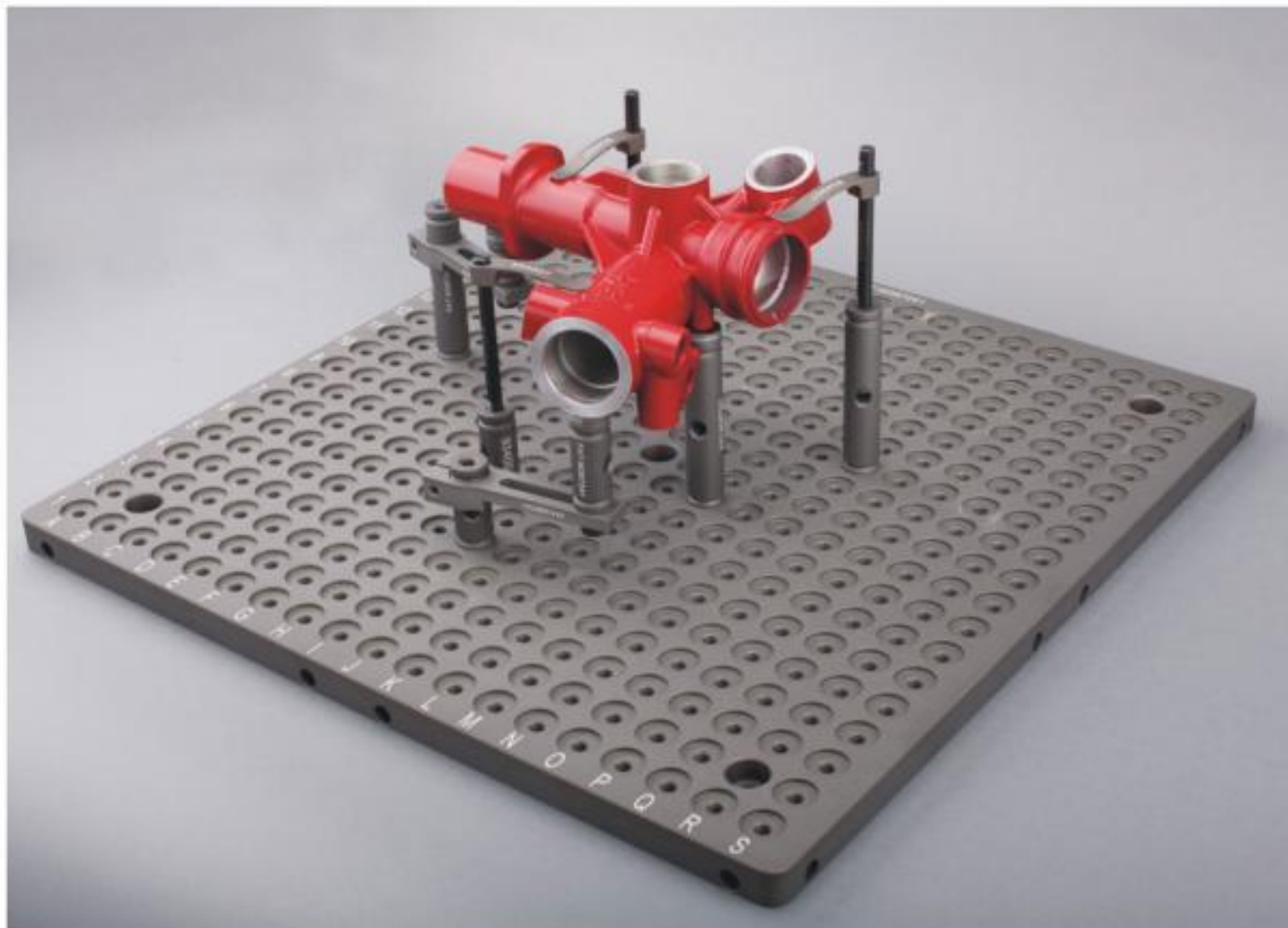

**55610** CHM-SE > Precision Universal Thin Chuck Pedestal

CHM-SE02



CHM-SE03



**Features:**

- ▶ Swivel base assembly with Thin 3-Jaw Chuck to achieve angle adjustments.
- ▶ Suitable for applying on 3D-Measuring to clamp round workpieces.
- ▶ For more info on Thin 3-Jaw Chuck, please refer to page H12.

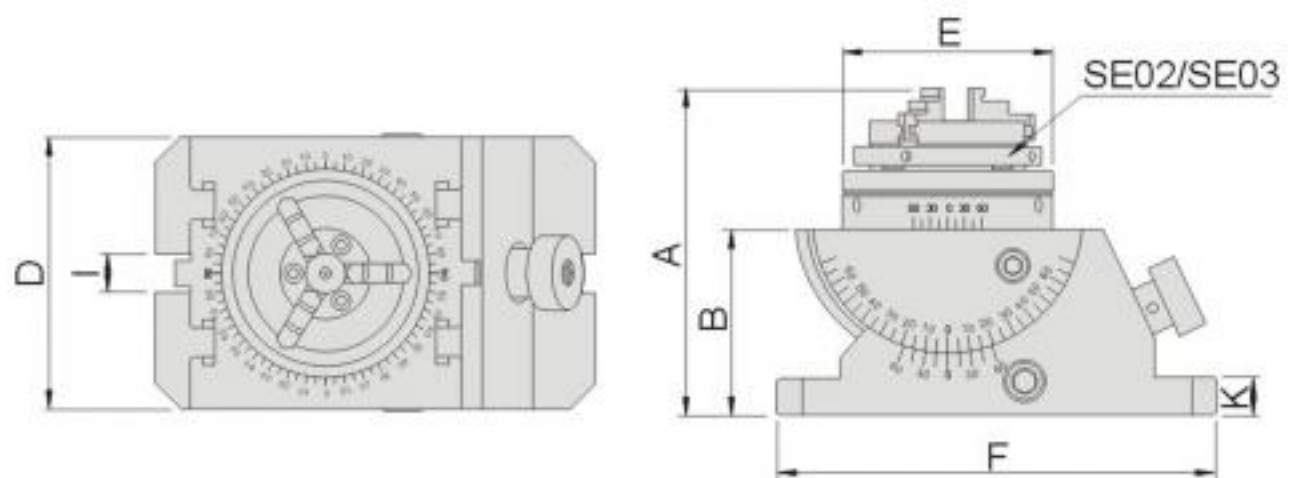

Unit:mm

Order No.	Model	A	B	D	E	F	I	K	N.W.
55610-01	CHM-SE02	133	75	110	∅85	178	16	15	11kg
55610-02	CHM-SE03	151	75	110	∅112	178	16	15	12kg



Gin Tech Precision Co., Ltd. Copyrighted; All Rights Reserved

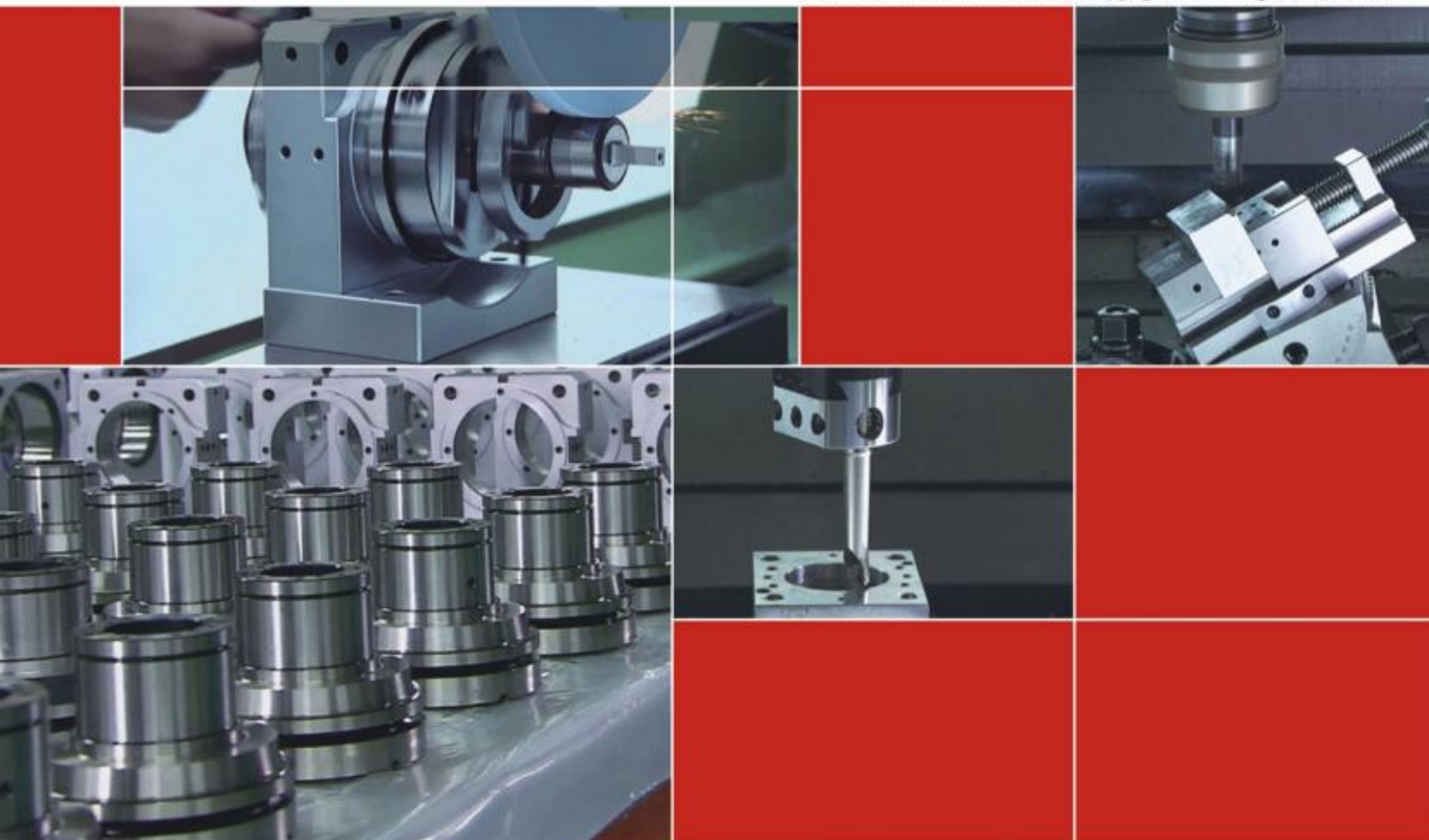

\*\*Gin Chan reserves right to amend the product content without prior notice\*\*

**精展精密科技股份有限公司 (總公司)**  
**GIN TECH PRECISION CO.,LTD.**

台灣238新北市樹林區保安街一段341巷7號  
Address: No 7, Lane 341, Sec. 1, Bau An Street, Shu lin Dist.,  
23841, New Taipei City, Taiwan  
TEL: 886-2-2681-8596 (Rep.)  Sales@ginchan.com.tw  
FAX: 886-2-2681-8516  www.ginchan.com.tw

**大陸總經銷**  
**東莞美商精展機械五金有限公司**  
**東莞市精展機械五金有限公司**  
**GIN CHAN MACHINERY & HARDWARE CO.,LTD.(DONGGUAN)**

廣東省東莞市大朗鎮石廈村金沙崗二路27號  
Tel : 86-769-8318-5858 (Rep.)  
Fax: 86-769-8318-5838/8313-5003  
 www.ginchan.com.cn  sales@ginchan.com.cn



**Scan Now!**

