

Tool Maker Vice

Grinding Accessories

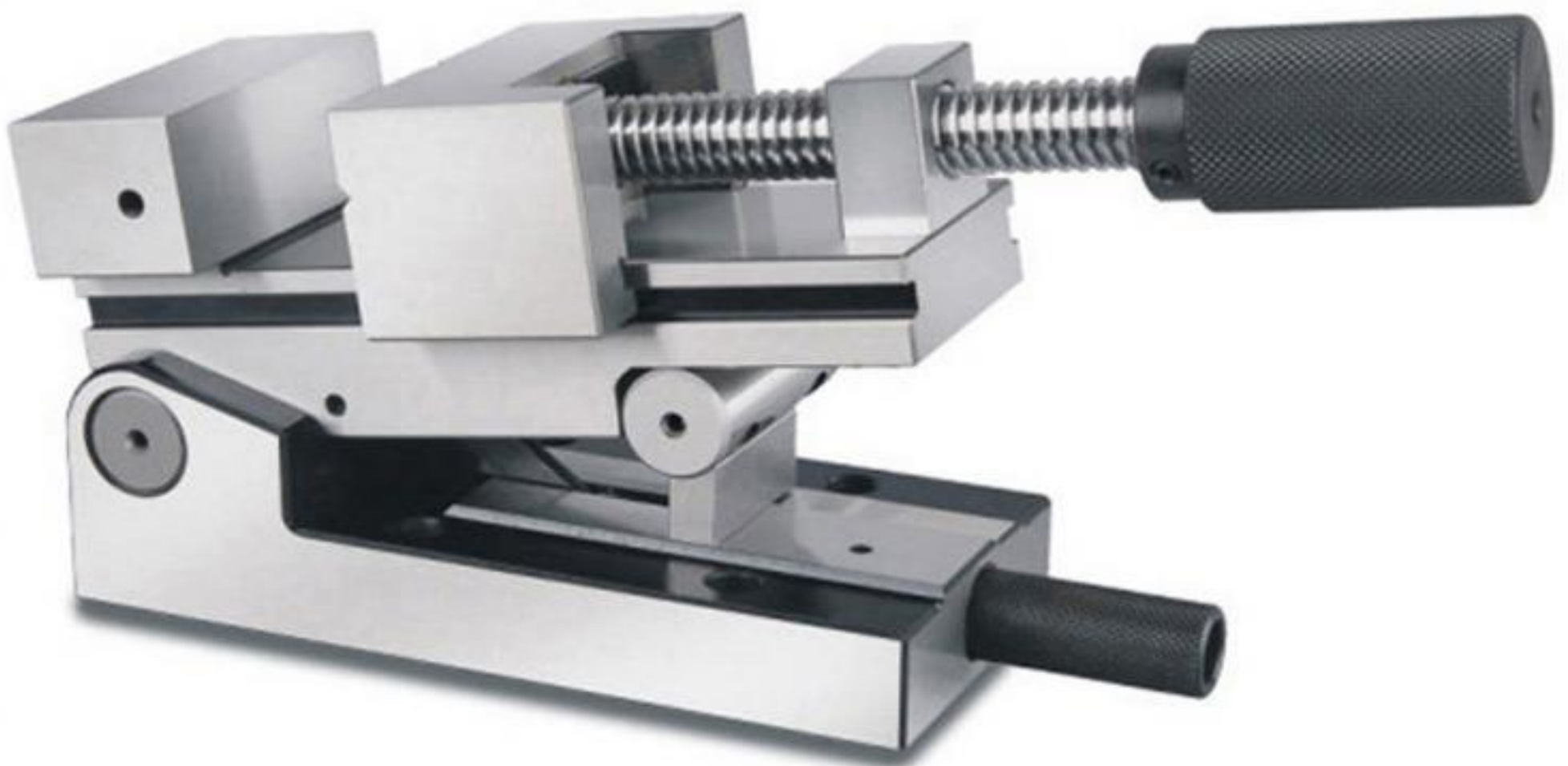

B01-B16

B01~10 Tool Maker Vise (Stainless Steel)

 52700 B01	 52715 B01	 52720 B01	 52725 B01	 52730 B02	 52735 B02
 52740 B02	 52745 B02	 52750 B03	 52755 B03	 52760 B03	 52765 B03
 52770 B04	 52775 B04	 52780 B04	 52790 B04	 52800 B05	
 52820-60/70 B07	 52820-90 B07	 52830 B09	 52840 B10	 52850 B10	

B11~16 Tool Maker Vise

 52860 B11	 52870 B11	 52880 B12	 52890 B12		
 52900 B13	 52910 B13	 52920 B14	 52930 B14		
 52940 B15	 52950 B15	 52960 B16	 52970 B16		

INDEX

B17~26

Wire EDM Clamp(Stainless Steel)



53000 B17



53005 B17



53010 B17



53015 B18



53020 B18



53025 B18



53030 B19



53035 B19



53040 B20



53045 B20



53050 B21



53055 B21



53060 B22



53065 B22



53068 B23



53070 B24



53100 B25



53105 B25



53110 B25



53112 B26



53115 B26



53120 B26

B27~36

Wire EDM Clamp(Stainless Steel)



53125 B27



53130 B27



53135 B28



53140 B28



53145 B29



53148 B30



53150 B31



53155 B31



53160 B31



53165 B32



53168 B33



53170 B33



53175 B34



53180 B35



53185 B36

Stainless Tool Maker Vise

Material : SUS440

Parallelism: within 0.003mm/100mm

Hardness: HRC48°~55°

Squareness: within 0.003mm/100mm

Unit: mm

52700

VJ10

▲ A delicate vise and suitable for clamping precision workpiece

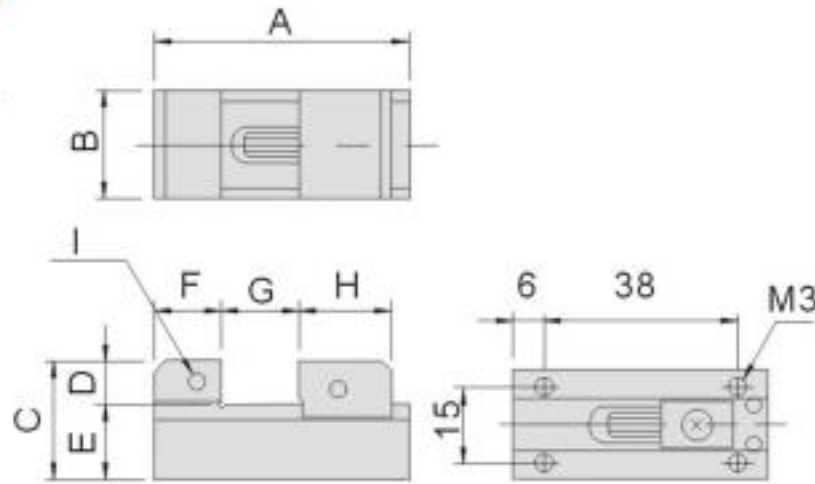

Spec.	VJ10
A	50
B	21
C	23.5
D	8.5
E	15
F	13
G	0~15
H	18
I	M3
N.W.	0.15kg

52715

VLW10

▲ Two way clamping and suitable for applying in EDM machine

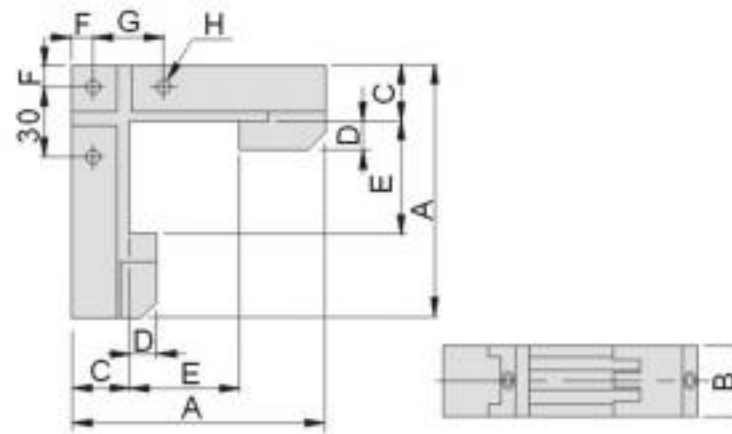

Spec.	VLW10
A	90
B	25
C	20
D	12
E	0~40
F	7.5
G	25
H	M5
N.W.	0.5kg

52720

VL 10

▲ Compact version precision vise, suitable for small precision workpiece, apply by wrench.
 ▲ VL10-2 has step groove on jaws.



52720-01 VL10-1
 52720-02 VL10-2

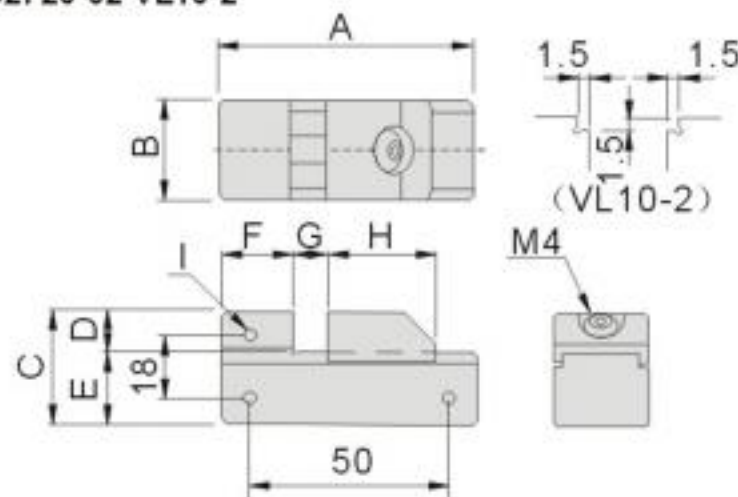

Spec.	VL10-1	VL10-2
A	65	65
B	25	25
C	32	32
D	12	12
E	20	20
F	20	20
G	0~20	0~20
H	25	25
I	M4	M4
N.W.	0.25kg	0.25kg

52725

VL20/30

▲ Suitable for high precision processing grinding / milling / EDM... apply by wrench to lock tight.



52725-20 VL20
 52725-30 VL30

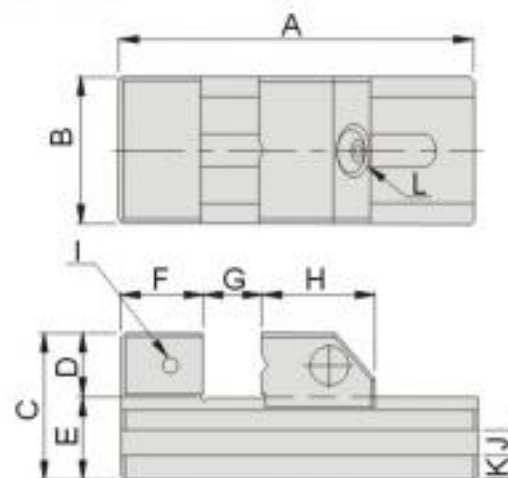

Spec.	VL20	VL30
A	140	180
B	50	72
C	53	62
D	25	30
E	28	32
F	25	35
G	0~75	0~100
H	40	45
I	M6	M6
J(WxD)	6x5	8x7
K	8.5	9
N.W.	1.5kg	3.0kg

Material :SUS440 Parallelism:within 0.003mm/100mm
 Hardness:HRC48°~55° Squareness:within 0.003mm/100mm

Unit:mm

52730 VSU10

▶ Screw rod design to lock tight, suitable for clamping small workpiece.

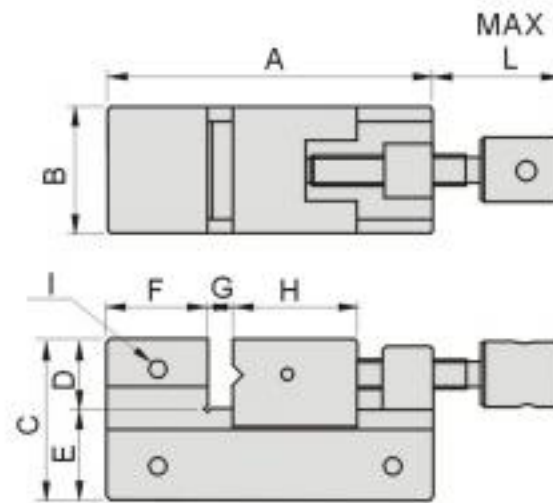

Spec.	VSU10
A	70
B	25
C	32
D	14
E	18
F	20
G	0~25
H	25
I	M4
L	43
N.W.	0.5kg

52735 VSU15

▶ Screw rod design to lock tight, suitable for clamping small workpiece.

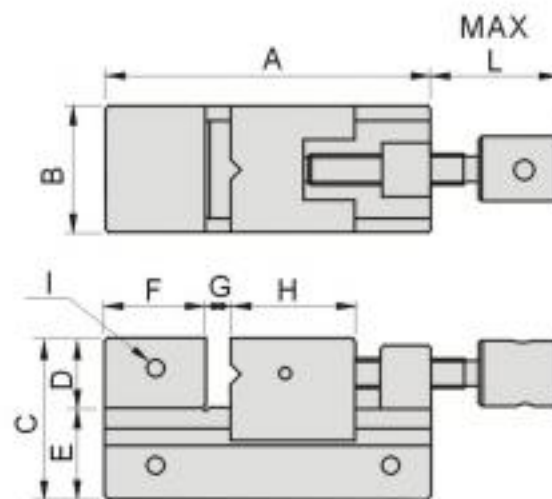

Spec.	VSU15
A	100
B	36
C	35
D	15
E	20
F	20
G	0~50
H	24
I	M5
L	76.5
N.W.	0.7kg

52740 VSU30

▶ Screw rod design to lock tight, suitable for clamping small workpiece to precision processing / grinding.

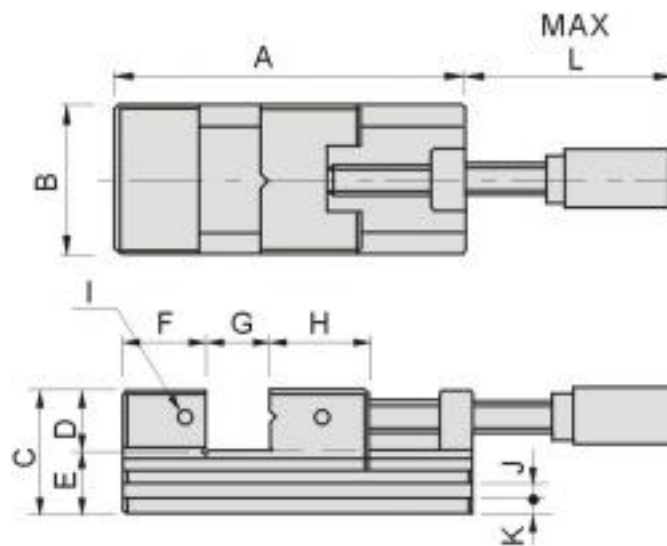

Spec.	VSU30
A	180
B	70
C	69
D	30
E	39
F	35
G	0~100
H	45
I	M6
J(WxD)	8x8
K	8
L	165.5
N.W.	4.2kg

52745 DSU80

▶ Compact structure, suitable for high precision processing work.

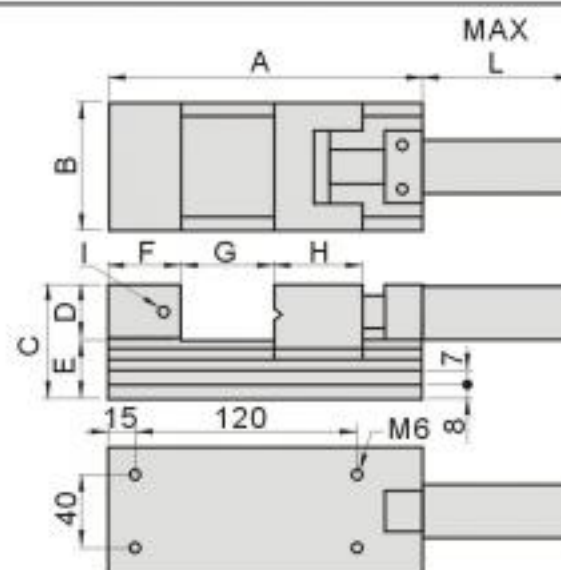

Spec.	DSU80
A	170
B	70
C	62
D	30
E	32
F	40
G	0~80
H	45
I	M6
L	82
N.W.	4.2kg

TOOL MAKER VISE

Stainless Tool Maker Vise

Material : SUS440

Parallelism: within 0.003mm/100mm

Hardness: HRC48°~55°

Squareness: within 0.003mm/100mm

Unit: mm

52750

DSU20/30

52750-20 DSU20
52750-30 DSU30

▶ Screw rod design to lock tight, suitable for clamping small precision workpiece.

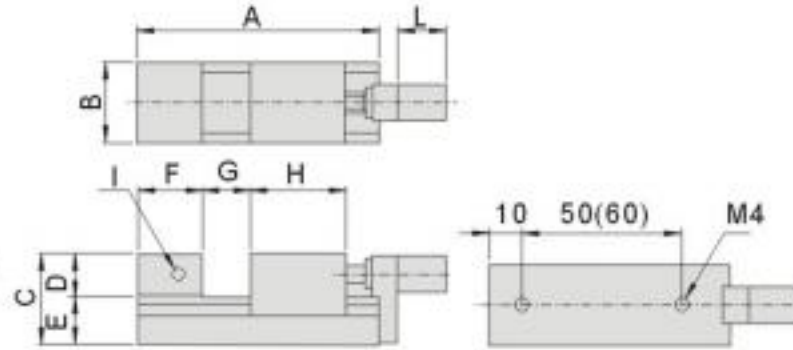

Spec.	DSU20	DSU30
A	75	95
B	25	30
C	28	35
D	13	15
E	15	20
F	20	20
G	0~20	0~30
H	30	40
I	M4	M4
L	20	20
N.W.	0.27kg	0.65kg

52755

DSU40/50

52755-40 DSU40
52755-50 DSU50

▶ Screw rod design to lock tight, suitable for clamping small precision workpiece.

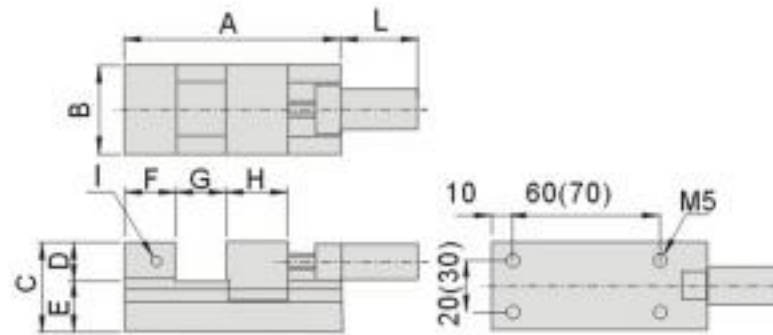

Spec.	DSU40	DSU50
A	95	110
B	35	45
C	35	45
D	15	20
E	20	25
F	20	25
G	0~40	0~50
H	24	24
I	M5	M5
L	45	50
N.W.	0.9kg	1.6kg

52760

PMV30

▶ Screw rod design to lock tight and has compact structure, suitable for clamping small workpiece to precision processing / grinding, especially on 5-axis machine center.

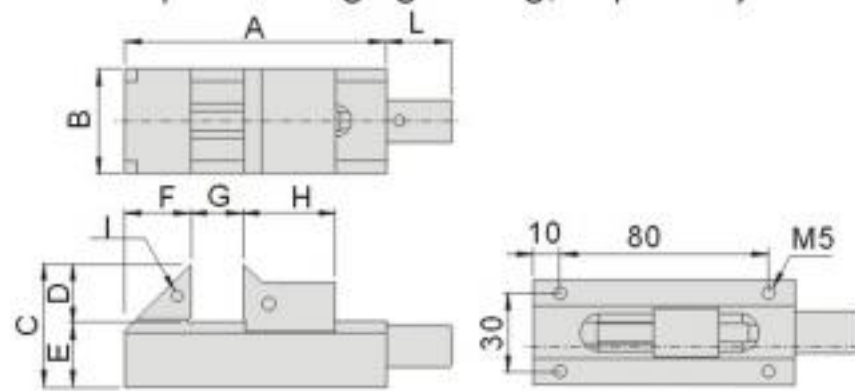

Spec.	PMV30
A	100
B	40
C	47
D	22
E	25
F	25
G	0~30
H	35
I	M4
L	31.5
N.W.	0.90kg

52765

PMV30F

▶ Screw rod design to lock tight and has compact structure, suitable for clamping small workpiece to precision processing / grinding, especially on 5-axis machine center.

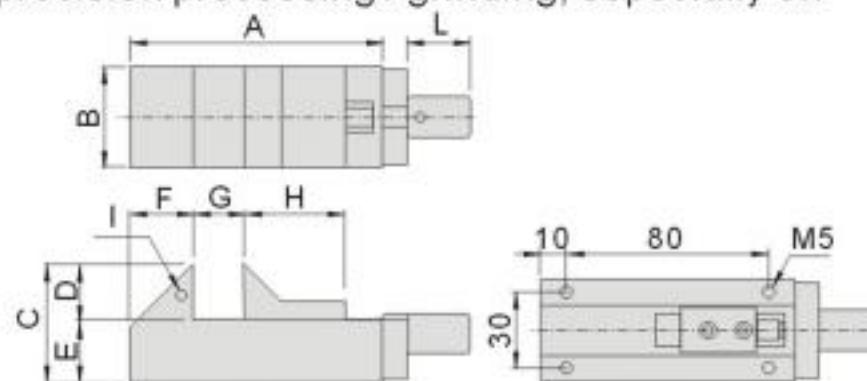

Spec.	PMV30F
A	100
B	40
C	47
D	22
E	25
F	25
G	0~30
H	40
I	M4
L	30
N.W.	0.93kg

TOOL MAKER VISE

Material : SUS440 Parallelism: within 0.003mm/100mm
 Hardness: HRC48°~55° Squareness: within 0.003mm/100mm

Unit: mm

52770 VE30/50

52770-30 VE30
52770-50 VE50

- ▶ 45° angle design for the jaw, suitable for precision and small workpiece which needs to form 45° angle.
- ▶ Standard equipment for adjusting work height position.

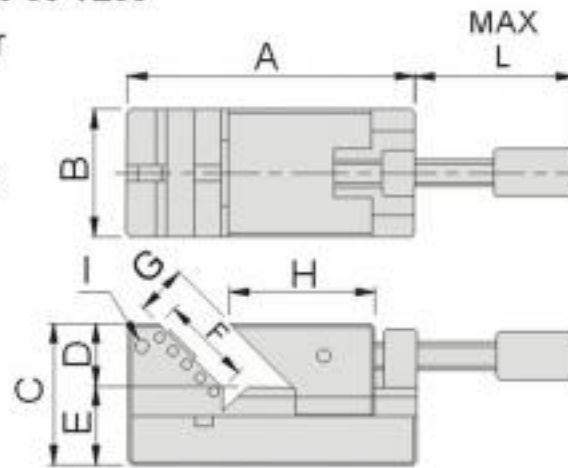

Spec.	VE30	VE50
A	62	90
B	30	50
C	37	44
D	15	20
E	22	24
F	21	33.9
G	0~11	0~26
H	37.5	45.4
I	M4	M4
L	33.5	65
N.W.	0.5kg	0.7kg

52775 VR40

- ▶ This vise has compact structure vise with special design to prevent any floating of workpiece when clamped.

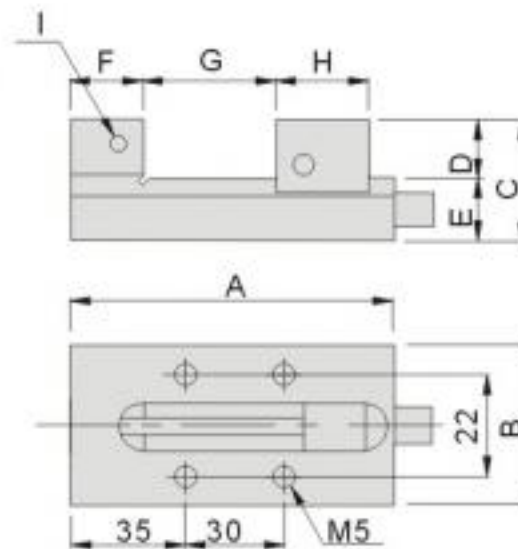

Spec.	VR40
A	100
B	40
C	40
D	15
E	25
F	25
G	0~40
H	25
I	M4
N.W.	1.0kg

52780 VK35

- ▶ This vise is adopting new structure and easier operation with higher accuracy and stability.

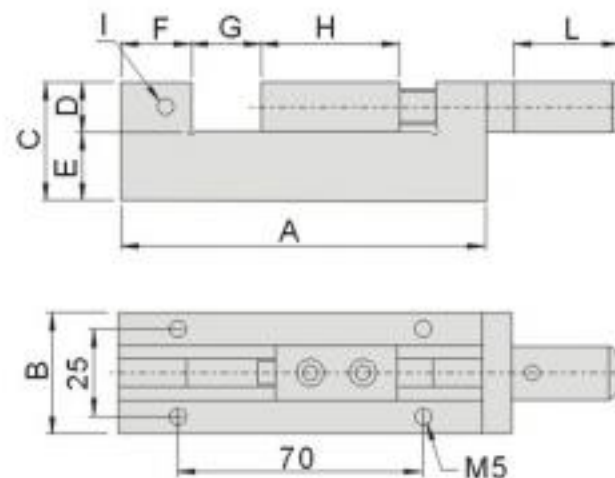

Spec.	VK35
A	105
B	35
C	35
D	15
E	20
F	20
G	0~30
H	40
I	M4
L	30
N.W.	1.1kg

52790 VSP50

- ▶ Precision sine vise, suitable for precision and small workpiece as well as EDM work.

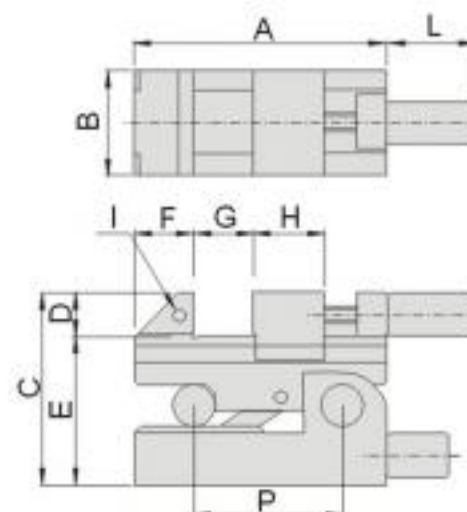

Spec.	VSP50
A	85
B	35
C	65
D	15
E	50
F	20
G	0~30
H	24
I	M4
L	37
P	50
N.W.	1.0kg

Tool Maker Vice

52800

VV

Ultra Precision Tool Maker Vice

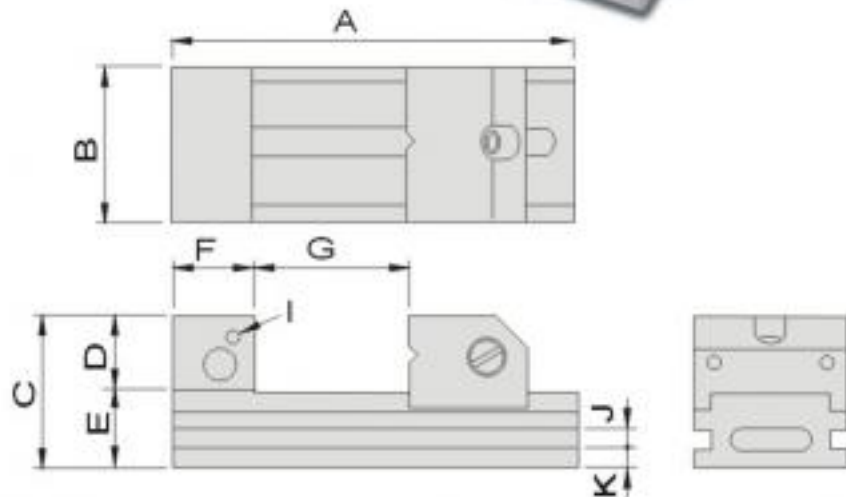

Features :

- ▶ VV Tool Maker Vice is made of high quality alloy tool steel (SKS)
- ▶ Special design to prevent distortion during clamping ensuring the accuracy for work processing on workpieces.
- ▶ With quick adjust spring function, clamping jaw can move and position easily.

Material	SKS
Hardness	HRC58°~60°
Sub-zero treatment	-185°C
Parallelism	within 0.003mm/100mm
Squareness	within 0.004mm/100mm

Unit:mm

Order No.	Model	A	B	C	D	E	F	G	I	J	K	N.W.
52800-20	VV20	150	48	53	25	28	25	0-70	M5	6	8.5	1.7kg
52800-30	VV30	190	73	70	35	35	38	0-100	M6	8	9.5	4.5kg
52800-40	VV40	230	98	80	40	40	46	0-125	M6	10	10	8.4kg
52800-50	VV50	300	125	98	48	50	60	0-160	M8	12	13	17.4kg
52800-60	VV60	350	150	100	50	50	60	0-210	M8	12	13	22.7kg

Super Precision Tool Maker Vice

- New improved VV Tool Maker Vice before clamping operation.

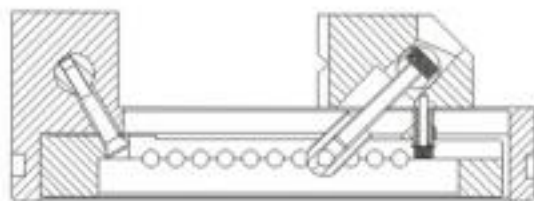

- Improved VV Tool Maker Vice, inner block face force when clamping and no twist or distortion is existing and achieve higher accuracy and stability.

Principle of anti-distortion

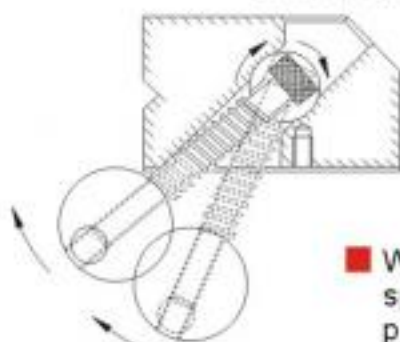
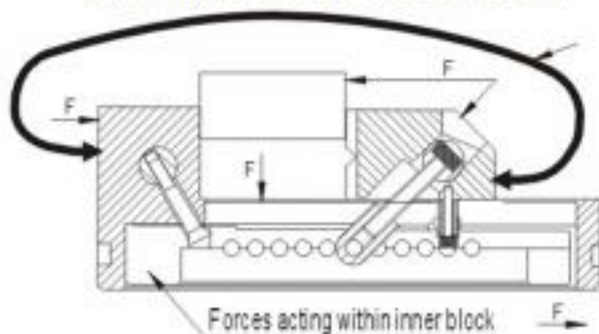

Upward spring

- When the fixed pin face the pressure from the spring, it generates upward twisting torque and push the screw match with the inner block.

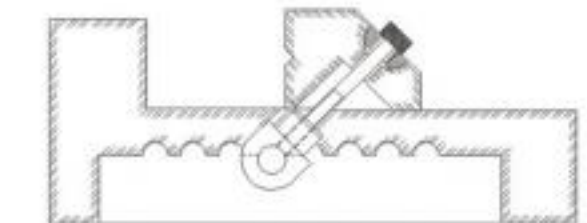

- Conventional vise has distortion or twist when clamping workpiece and thus lead to poor accuracy.

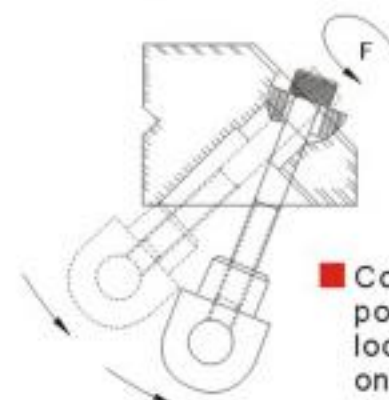
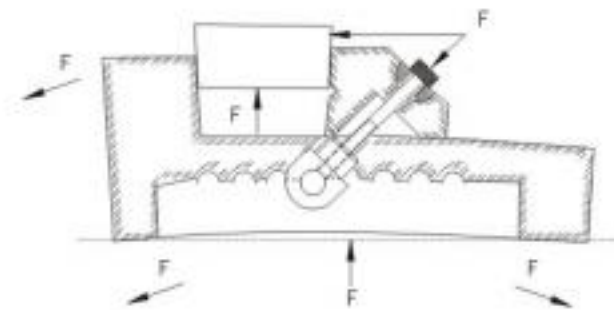

- Conventional vise needs to position the fix pin when you loose the screw, it all depends on manual work.

52800

VV

Ultra Precision Tool Maker Vise

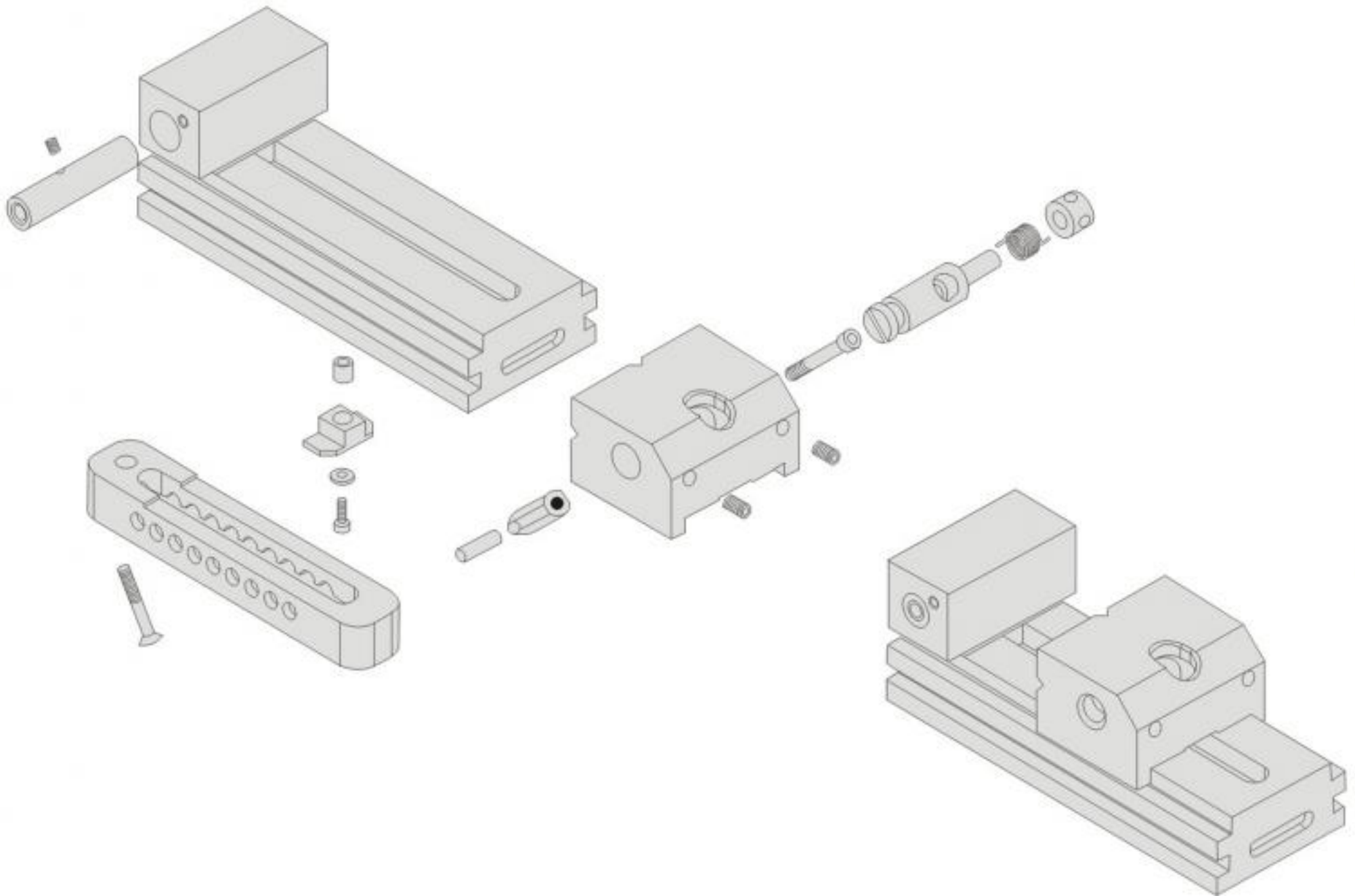

TOOL MAKER VISE

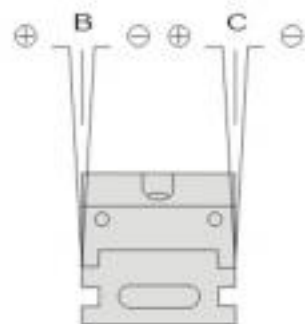
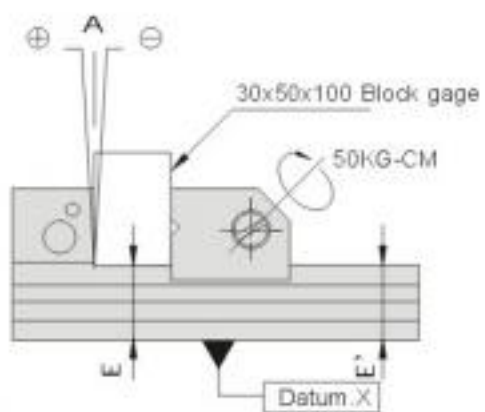
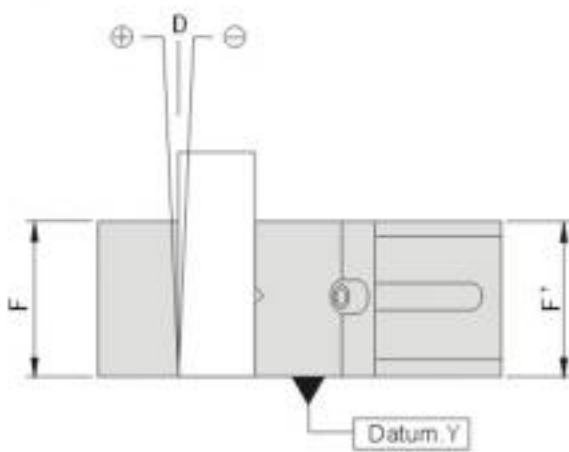

		Unit:µm
Position	Inspection description	Tolerance
A	Perpendicularity to Datum X	±4
B	Perpendicularity to Datum X	±4
C	Perpendicularity to Datum X	±4
D	Perpendicularity to Datum Y	±4
E	Perpendicularity to Datum X	±3
F	Perpendicularity to Datum Y	±3

Tool Maker Vise

52820

HU

Tool Maker Vise



HU60



HU70



HU90

Features :

- ▲ Made of high quality alloy tool steel (SKS3) and tempering & sub-zero treatment.
- ▲ Anti-distortion design with screw rod function to lock, suitable for applying on precision processing work.

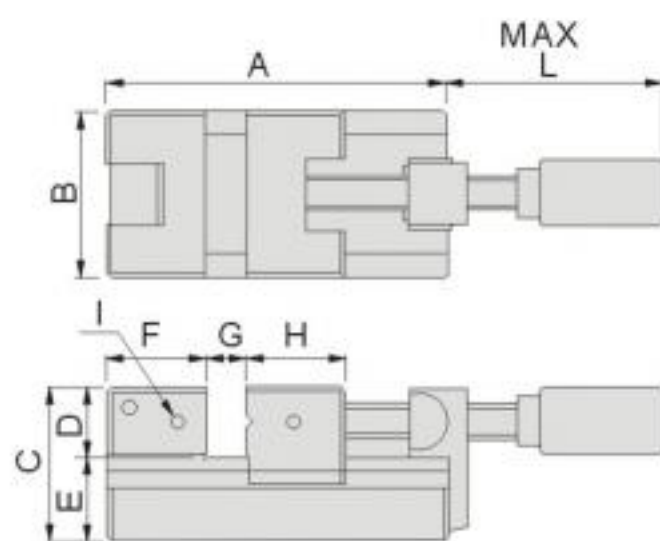

HU60/70

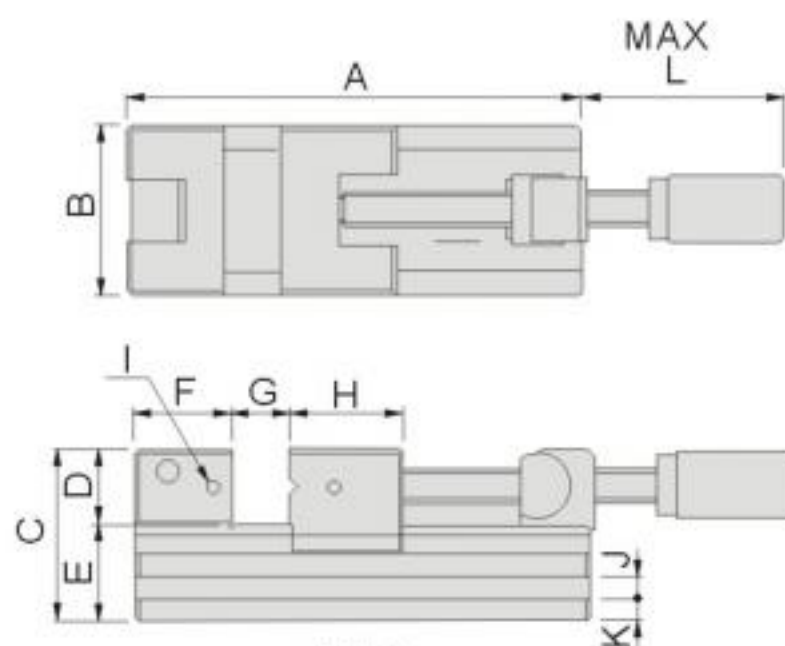

HU90

Material	SKS
Hardness	HRC56°~60°
Parallelism	within 0.003mm/100mm
Squareness	within 0.005mm/100mm

Order No.	Model	A	B	C	D	E	F	G	H	I	L	N.W.
52820-60	HU60	122	60	60	25	35	35	0~47	40	M6	105	2.5kg
52820-70	HU70	172	70	70	30	40	40	0~80	45	M6	149.5	4.7kg

Unit:mm

Order No.	Model	A	B	C	D	E	F	G	H	I	J(WxD)	K	L	N.W.
52820-90	HU90	237	90	90	40	50	50	0~125	50	M6	10x7	10	201	10.3kg

Unit:mm

TOOL MAKER VISE

Anti-distortion

Adopting built-in Anti-distortion structure

Comparison



HU60



HU70



HU90

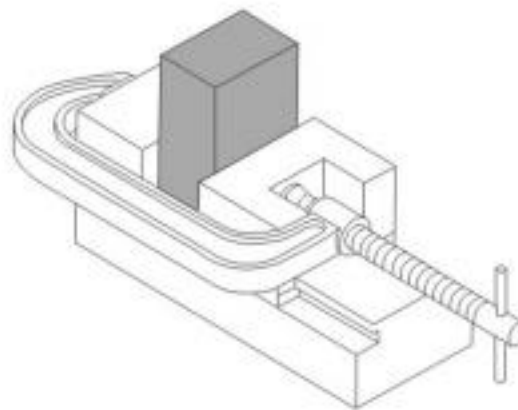
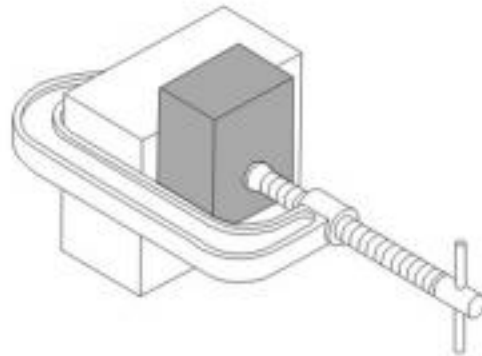
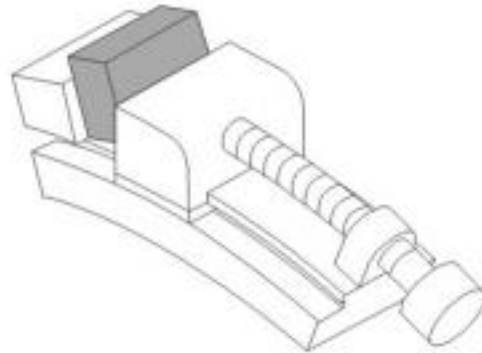

General Tool Maker Vise will distort from clamping stress and thus impede the precision processing.

Applying fixture block is essential for high precision processing, however, it is not cost effective.

Applying fixture block and the vise it achieve cost effective and high precision processing.



TOOL MAKER VISE

Making inbuilt fixture into vise and it help the precision processing due to the distortion stress will react on fixture. Thus no distortion influent the parallelism and perpendicularity.

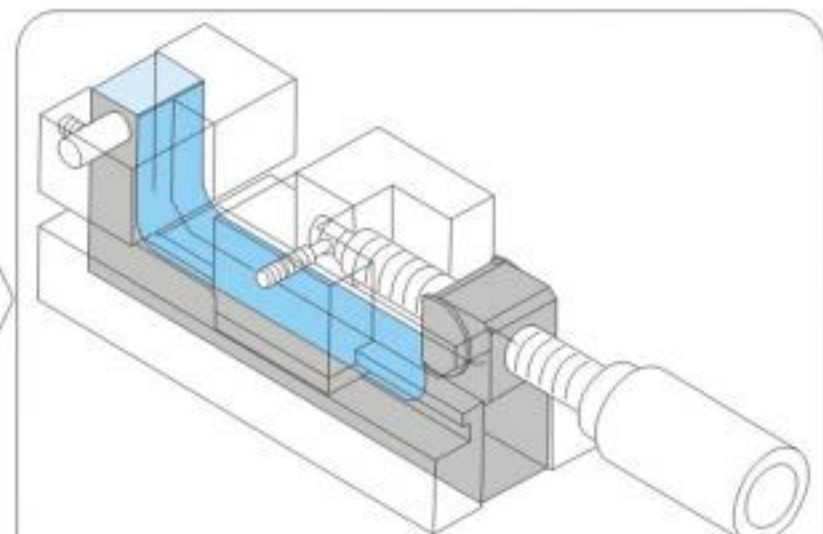
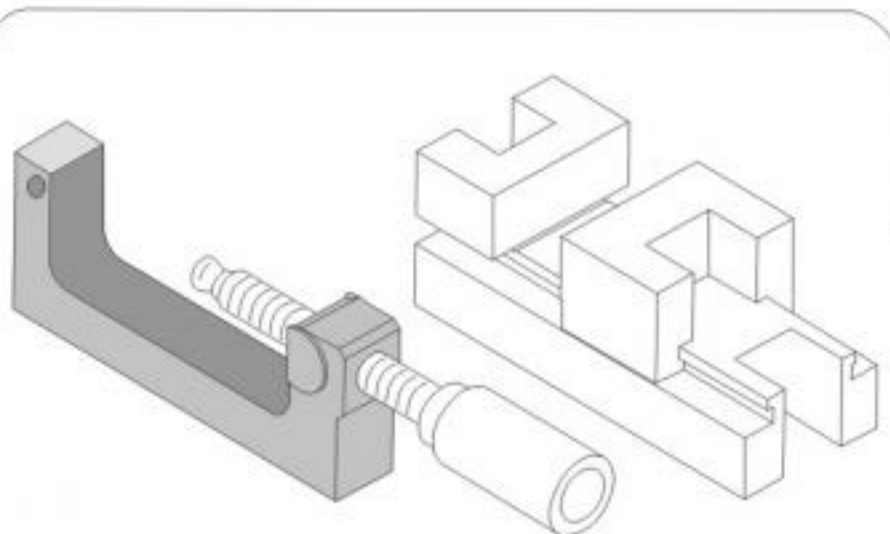

Tool Maker Vise

52830

SV

Super Precision Tool Maker Vise

SV34



SV45/70/90/120



Features :

- ▲ Made of high quality alloy tool steel (SKS3) with Sub-zero treatment.
- ▲ The best type of Tool Maker Vise both in structure and accuracy.
- ▲ Due its high precision and stability, it is well-known in Japan and Europe and sold to worldwide range.
- ▲ Single side oblique angle design can automatically mend the distortion from the body.

Material	SKS
Hardness	HRC58°~60°
Sub-zero treatment	-185°C
Parallelism	within 0.003mm/100mm
Squareness	within 0.004mm/100mm

SV34

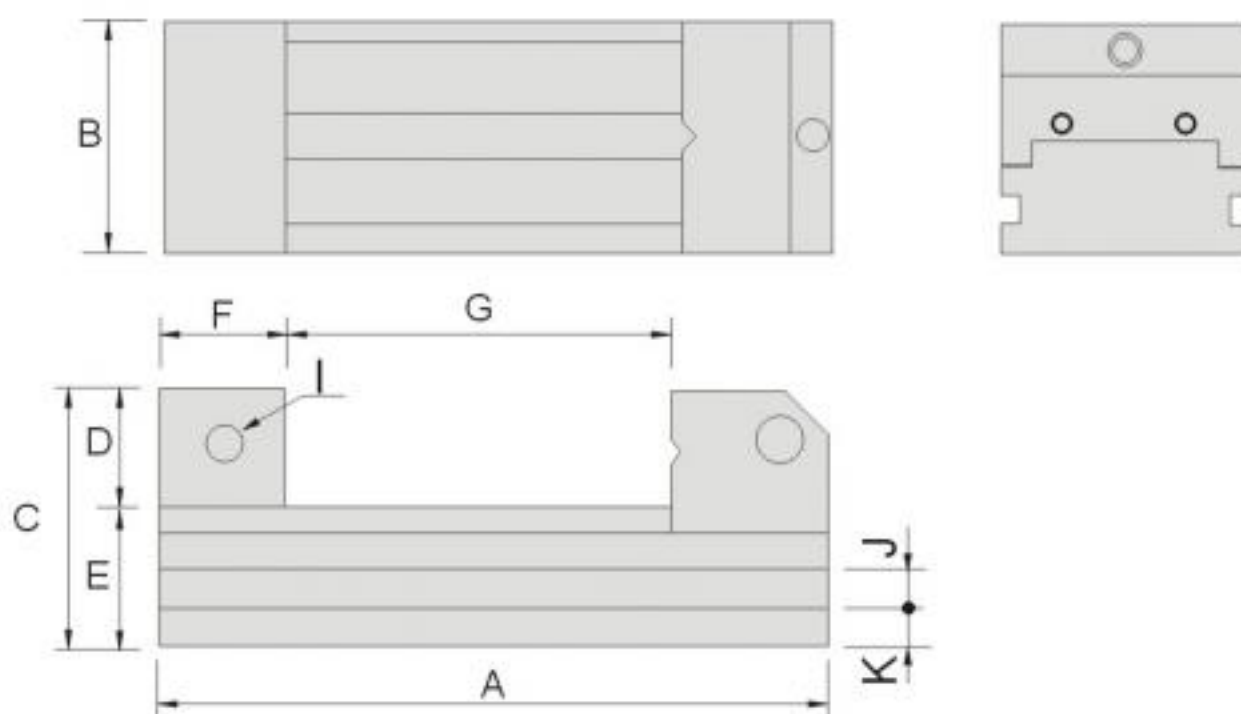
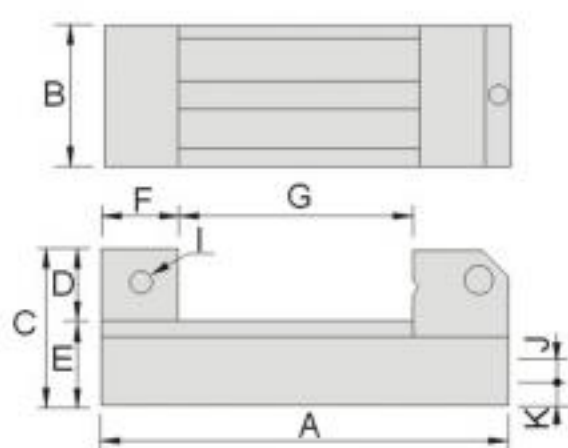

Unit:mm

Order No.	Model	A	B	C	D	E	F	G	I	J	K	N.W.
52830-34	SV34	75	34	35	15	20	20	0-25	M4	-	-	0.5kg
52830-45	SV45	110	45	45	20	25	25	0-50	M5	6	8	1.0kg
52830-70	SV70	160	70	62	30	32	33	0-80	M6	8	9	3.0kg
52830-90	SV90	210	90	80	40	40	40	0-115	M6	10	12	6.7kg
52830-120	SV120	286	120	90	40	50	60	0-150	M6	12	14	14.9kg

52840

A

Super Precision Tool Maker Vice

A20

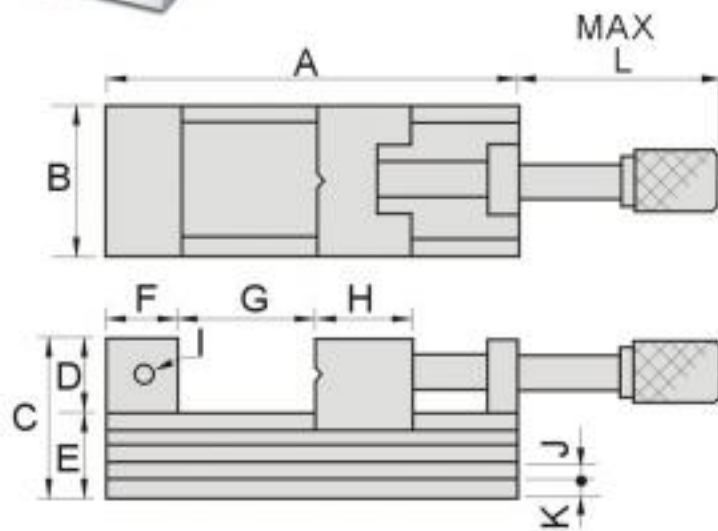

Features :

- ▶ A type Super Precision Tool Maker Vise has complete specifications with handle screw bar design. Hex wrench can be applied for lock tighter.
- ▶ Precision screw bar and screw nut, ensure the lasting durability, every part is precision ground square and parallel.
- ▶ New one-way bevel design that automatically corrects the amount of deformation of the body.

Material	SK2
Hardness	HRC56°~58°
Parallelism	within 0.003mm/100mm
Squareness	within 0.004mm/100mm

Unit:mm

Order No.	Model	A	B	C	D	E	F	G	H	I	J	K	L	N.W.
52840-20	A20	140	48	55	25	30	25	0-75	40	M6	-	-	117	2.3kg
52840-25	A25	160	63	69	30	39	30	0-85	45	M6	8	9	129	3.8kg
52840-30	A30	180	73	78	35	43	35	0-95	50	M6	8	10	132	6.0kg
52840-40	A40	230	98	92	45	47	45	0-120	50	M8	10	11	172	11.3kg

52850

AS

Ultra Precision Tool Maker Vise

AS60



AS70



Features :

- ▶ New one-way bevel design that automatically corrects the amount of deformation of the body.

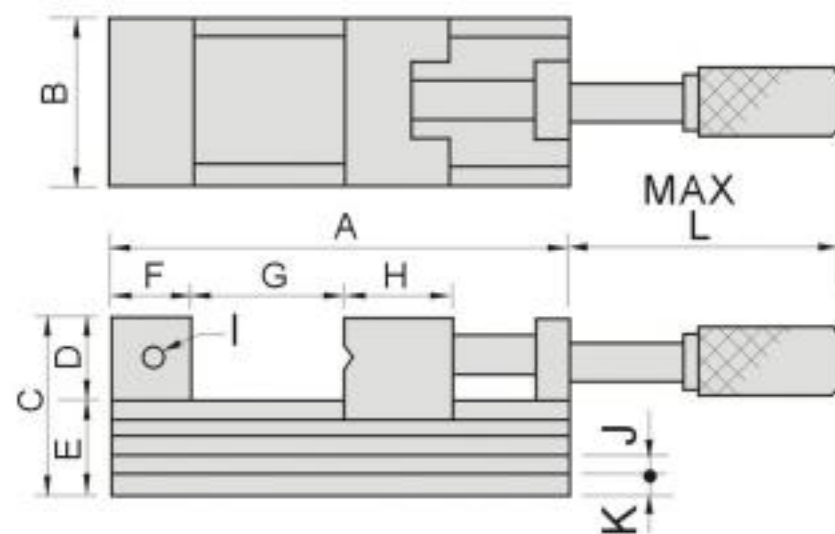

Unit:mm

Order No.	Model	A	B	C	D	E	F	G	H	I	J	K	L	N.W.
52850-60	AS60	92	60	50	25	25	25	0-32	30	M5	6	4.5	60	1.6kg
52850-70	AS70	165	70	62	30	32	33	0-80	45	M6	7	8	140	4.0kg
52850-90	AS90	212	90	80	40	40	40	0-120	50	M6	9	9	192	8.4kg

TOOL MAKER VISE

Tool Maker Vise

52860 V100 Precision Sine Vise



Features :

- ▶ Suitably using in grinding, cutting, drilling, marking and measuring.
- ▶ New structure design make easier operation with higher accuracy and stability.
- ▶ Optional block gauge for sine angle calculation see order no. 55070

Material	SKS
Hardness	HRC58°~60°
Sub-zero treatment	-185°C
Parallelism	within 0.003mm/100mm
Squareness	within 0.005mm/100mm
Max. angle & tolerance	46°±15"

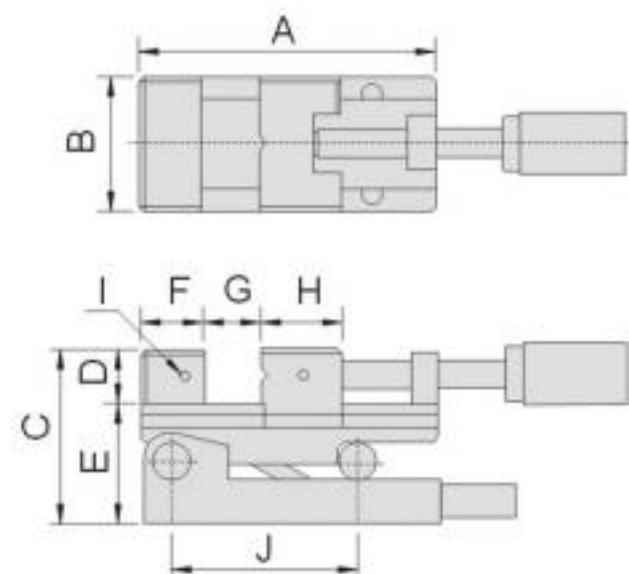

Spec	V100
A	160
B	73
C	93
D	30
E	63
F	33
G	80
H	45
I	M5
J	100
N.W	5.6kg

TOOL MAKER VISE

52870 VC100 Precision Sine Vise

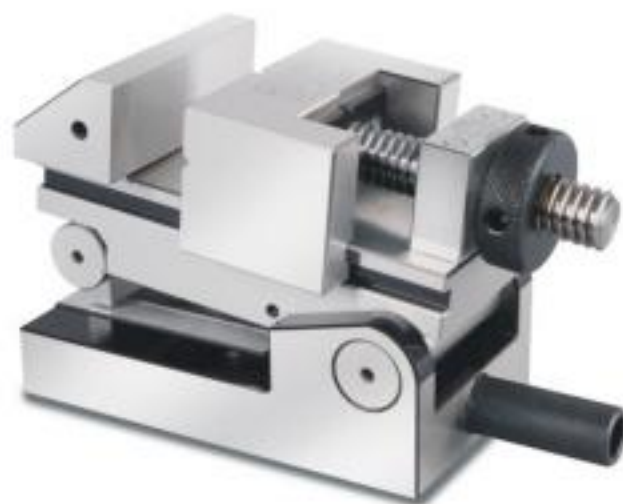

Features :

- ▶ Suitably using in grinding, cutting, drilling, marking and measuring.
- ▶ New structure design make easier operation with higher accuracy and stability.
- ▶ Optional block gauge for sine angle calculation see order no. 55070

Material	SKS
Hardness	HRC58°~60°
Sub-zero treatment	-185°C
Parallelism	within 0.003mm/100mm
Squareness	within 0.005mm/100mm
Max. angle & tolerance	46°±15"

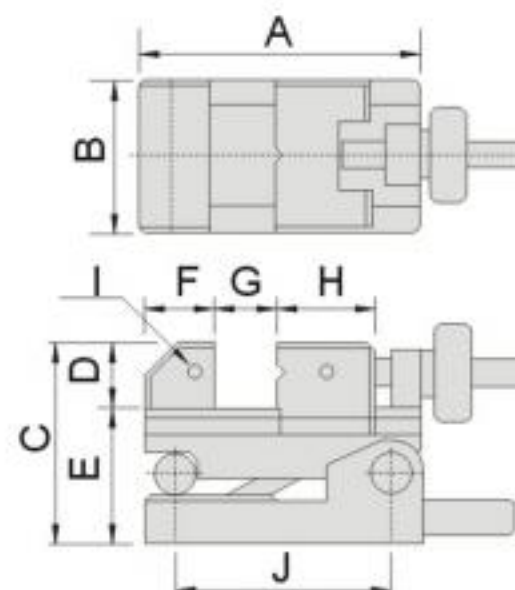

Spec	VC100
A	130
B	73
C	93
D	30
E	63
F	33
G	45
H	45
I	M5
J	100
N.W	4.6kg

52880 L50 Precision Sine Vise



Features :

- ▶ Suitably using in grinding, cutting, drilling, marking and measuring.
- ▶ New structure design make easier operation with higher accuracy and stability.
- ▶ The quotient is equal to the sine of the resulting angle, which can be found in a trigonometric table or by using a scientific calculator.
- ▶ Optional block gauge for sine angle calculation see order no. 55070

Material	SKS
Hardness	HRC58°~60°
Sub-zero treatment	-185°C
Parallelism	within 0.003mm/100mm
Squareness	within 0.005mm/100mm
Max. angle & tolerance	46°±15"

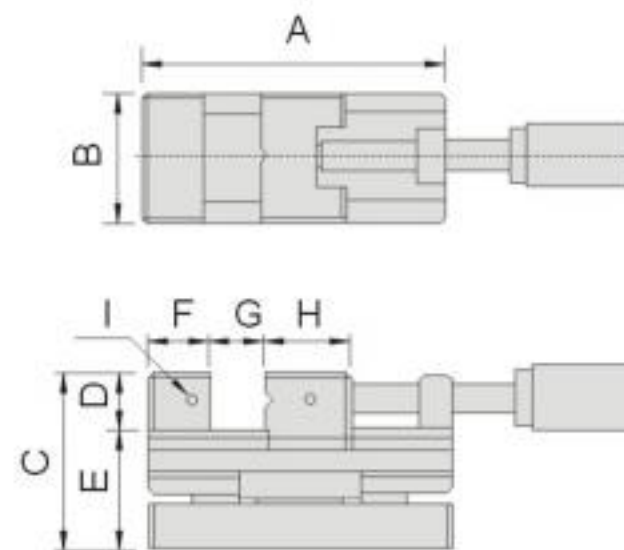

Spec	L50
A	160
B	73
C	93
D	30
E	63
F	33
G	80
H	45
I	M5
N.W	5.8kg

TOOL MAKER VISE

52890 CSV100 Precision Compound Sine Vise



Features :

- ▶ Suitably using in grinding, cutting, drilling, marking and measuring.
- ▶ New structure design make easier operation with higher accuracy and stability.
- ▶ The quotient is equal to the sine of the resulting angle, which can be found in a trigonometric table or by using a scientific calculator.
- ▶ Optional block gauge for sine angle calculation see order no. 55070

Material	SKS
Hardness	HRC58°~60°
Sub-zero treatment	-185°C
Parallelism	within 0.003mm/100mm
Squareness	within 0.005mm/100mm
Max. angle & tolerance	46°±15"

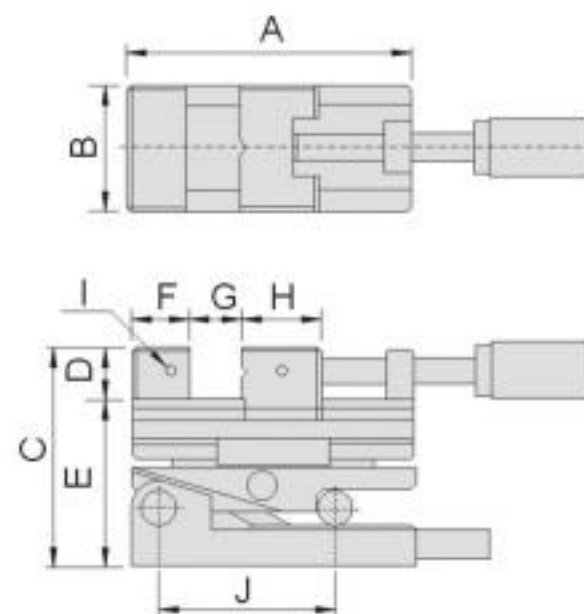

Spec	CSV100
A	160
B	73
C	124
D	30
E	94
F	33
G	80
H	45
I	M5
J	100
N.W	7.5kg

Tool Maker Vise

52900

VSB

Tool Maker Vise



Features :

- ▶ New structure design make easier operation with higher accuracy and stability.

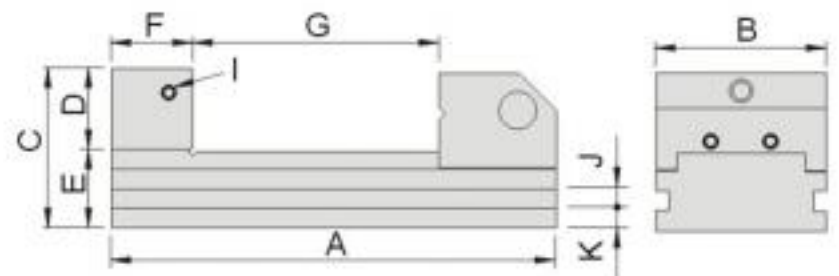

Material	SK2
Hardness	HRC55°~60°
Parallelism	within 0.003mm/100mm
Squareness	within 0.005mm/100mm

Unit:mm

Order No.	Model	A	B	C	D	E	F	G	I	J	K	N.W.
52900-15	VSB15	105	36	48	20	28	25	0-40	M6	7	9	0.8kg
52900-20	VSB20	150	48	53	25	28	25	0-75	M6	6	8.5	1.5kg
52900-25	VSB25	176	63	59	30	29	30	0-95	M6	8	7.5	2.6kg
52900-30	VSB30	190	73	68	35	33	35	0-105	M6	8	9	4.0kg
52900-40	VSB40	245	98	90	45	45	45	0-135	M6	10	14	9.5kg

52910

VS

Tool Maker Vise



52910-10
VS10

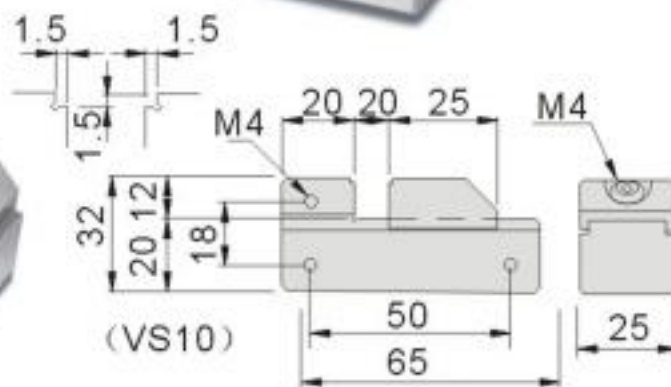

Features :

- ▶ Precision Tool Maker Vises are suitable for all machining operations.

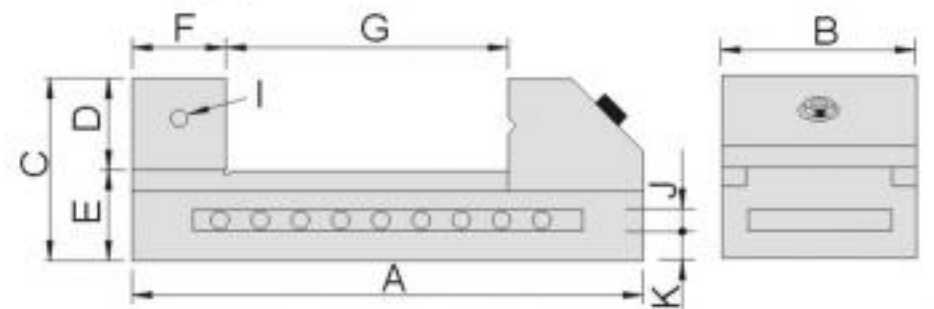

Material	SK2
Hardness	HRC55°~60°
Parallelism	within 0.003mm/100mm
Squareness	within 0.005mm/100mm

Unit:mm

Order No.	Model	A	B	C	D	E	F	G	I	J	K	N.W.
52910-15	VS15	105	36	48	20	28	25	0-40	M6	7	9	0.9kg
52910-20	VS20	150	50	53	25	28	30	0-80	M6	8	8	1.6kg
52910-25	VS25	175	63	63	32	31	35	0-90	M6	10	11	2.9kg
52910-30	VS30	190	73	70	35	35	35	0-100	M6	10	12	4.3kg
52910-35	VS35	235	88	80	40	40	40	0-130	M8	12	14	6.8kg
52910-40	VS40	245	100	90	45	45	45	0-130	M8	12	16	10kg
52910-50	VS50	285	125	100	50	50	45	0-160	M8	14	18	15kg

52920 vs **Tool Maker Vise (Big)**



Material	SK2
Hardness	HRC55°~60°
Parallelism	within 0.003mm/100mm
Squareness	within 0.005mm/100mm

Features :

- ▶ One piece body construction.
- ▶ Holes and locking set screw provide adjustable positions.

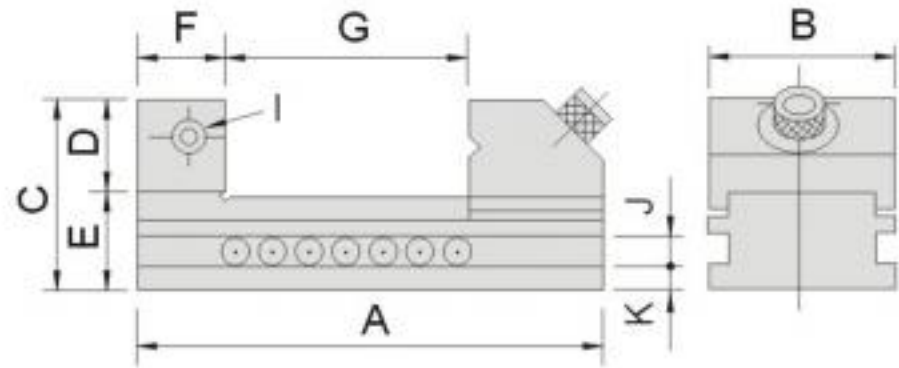

Unit:mm

Order No.	Model	A	B	C	D	E	F	G	I	J	K	N.W.
52920-60	VS60	330	150	100	50	50	50	0-180	M8	14	18	20kg
52920-80	VS80	360	200	110	55	55	55	0-205	M10	14	20.5	33kg

TOOL MAKER VISE

52930 VB **Tool Maker Vise**



Material	Tool Steel
Hardness	HRC52°~58°
Parallelism	within 0.005mm/100mm
Squareness	within 0.008mm/100mm

Features :

- ▶ One piece body construction.
- ▶ Holes and locking set screw provide adjustable positions.

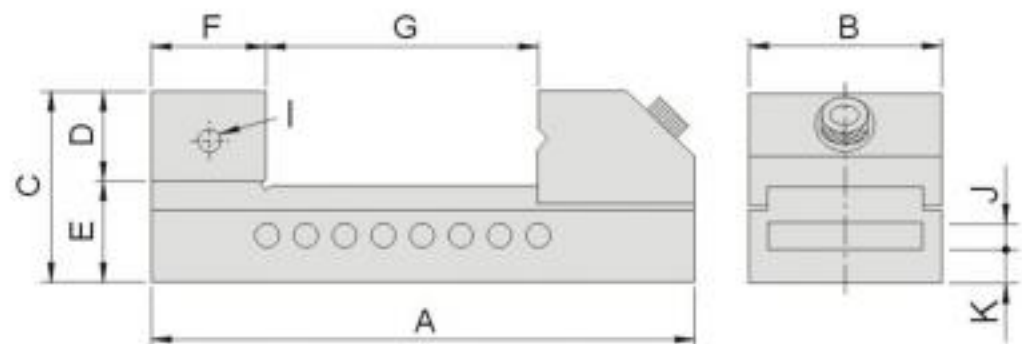

Unit:mm

Order No.	Model	A	B	C	D	E	F	G	I	J	K	N.W.
52930-15	VB15	100	36	48	20	28	25	0-40	M5	8	8	1.0kg
52930-20	VB20	150	50	53	25	28	30	0-80	M6	8	8	1.7kg
52930-25	VB25	175	63	63	32	31	35	0-90	M6	10	11	3.0kg
52930-30	VB30	190	73	70	35	35	35	0-100	M6	10	12	4.2kg
52930-35	VB35	235	88	80	40	40	40	0-130	M8	12	14	7.0kg
52930-40	VB40	245	100	90	45	45	45	0-130	M8	12	16	9.0kg
52930-50	VB50	285	125	100	50	50	45	0-160	M8	14	18	15.0kg

Tool Maker Vise

52940

SVA

Tool Maker Sine Vise



Features :

- ▶ Maximum angle of 46°. Tolerance ± 15 sec.
- ▶ Optional block gauge for sine angle calculation see order no. 55070

Material	Tool Steel
Hardness	HRC52°~58°
Parallelism	within 0.005mm/100mm
Squareness	within 0.005mm/100mm

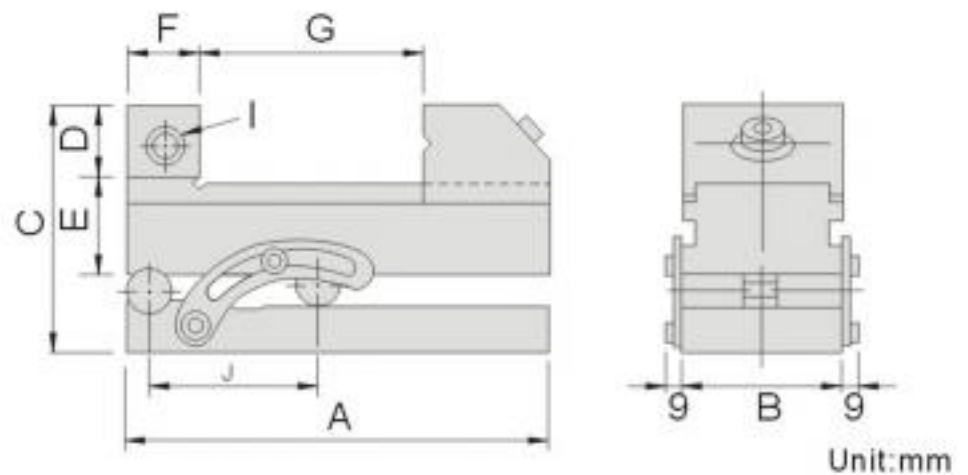

Order No.	Model	A	B	C	D	E	F	G	I	J	N.W.
52940-20	SVA20	150	48	88.5	25	28	25	0-75	M6	100	2.9kg
52940-25	SVA25	176	63	94.5	30	29	30	0-85	M6	100	4.6kg
52940-30	SVA30	190	73	103.5	35	33	35	0-95	M6	100	6.4kg
52940-40	SVA40	245	98	126.5	45	45	45	0-125	M6	150	14.1kg

52950

SV

Tool Maker Sine Vise



Features :

- ▶ Maximum angle of 46°. Tolerance ± 15 sec.
- ▶ Optional block gauge for sine angle calculation see order no. 55070

Material	Tool Steel
Hardness	HRC52°~58°
Parallelism	within 0.005mm/100mm
Squareness	within 0.005mm/100mm

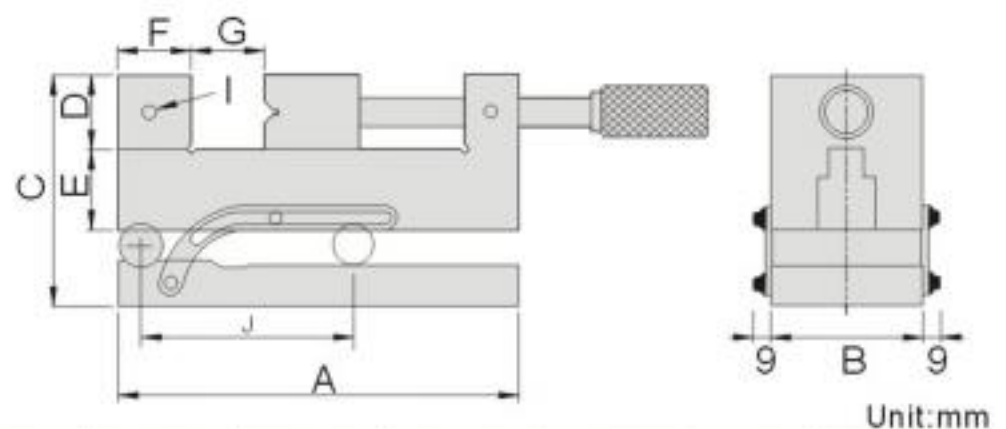

Order No.	Model	A	B	C	D	E	F	G	I	J	N.W.
52950-200	SV200	156	48	87.5	25	27	25	0-63	M6	100	3.7kg
52950-250	SV250	176	63	98.5	30	33	30	0-73	M6	100	6.0kg
52950-300	SV300	190	73	103.5	35	33	35	0-76	M6	100	8.0kg
52950-400	SV400	255	98	120.5	40	42	40	0-120	M8	150	16.0kg

52960

VSD

Tool Maker Vise



Material	Tool Steel
Hardness	HRC52°~58°
Parallelism	within 0.004mm/100mm
Squareness	within 0.006mm/100mm

Features :

- ▶ New structure design for minimum clearance occurred when lock tight also handle with hex hole can apply hex wrench to lock tighter. Simple dismantle the screw bar when worn.

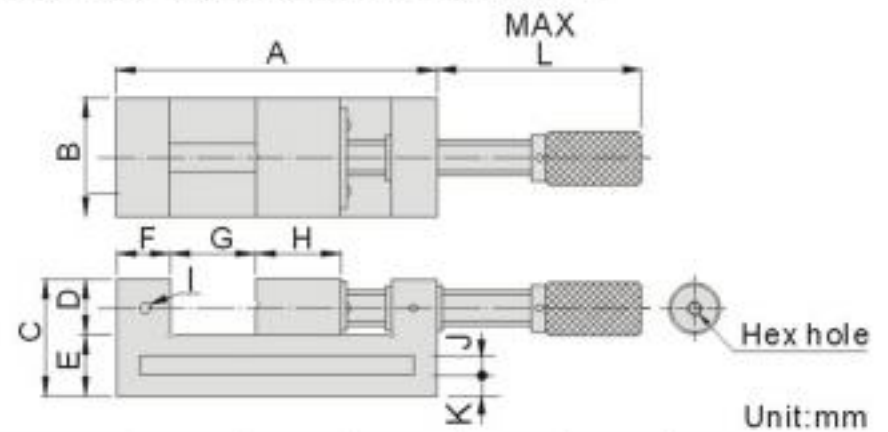

Order No.	Model	A	B	C	D	E	F	G	H	I	J	K	L	N.W.
52960-20	VSD20	156	48	52	25	27	25	0-63	34	M6	8	9.5	125	2.3kg
52960-25	VSD25	176	63	63	30	33	30	0-73	40	M6	10	11.5	147	4.0kg
52960-30	VSD30	190	73	73	35	38	35	0-76	45	M6	10	14	151	5.5kg
52960-40	VSD40	255	98	82	40	42	40	0-120	50	M8	12	15	196	11.0kg
52960-50	VSD50	310	125	100	50	50	50	0-152	57	M8	14	18	231	18.3kg
52960-60	VSD60	325	150	100	50	50	50	0-165	60	M8	14	18	245	20.0kg
52960-80	VSD80	350	200	110	55	55	45	0-195	70	M10	16	19.5	281	34.5kg

TOOL MAKER VISE

52970

PGV

Precision Hydraulic Vise



Features :

- ▶ Adopting hydraulic structure with stronger clamping force.
- ▶ High precision and quality, popular in worldwide.

Material	Tool Steel
Hardness	HRC52°~58°
Max clamping force	1500kgf
Parallelism	within 0.005mm/100mm
Squareness	within 0.008mm/100mm

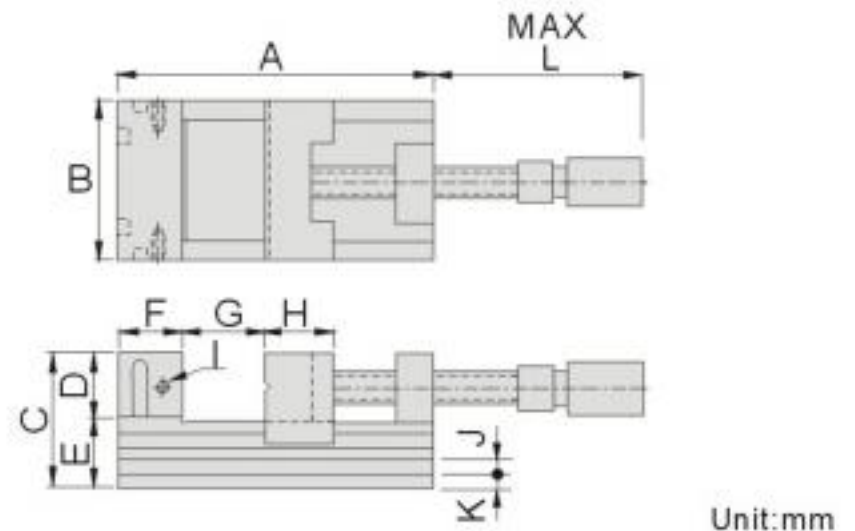
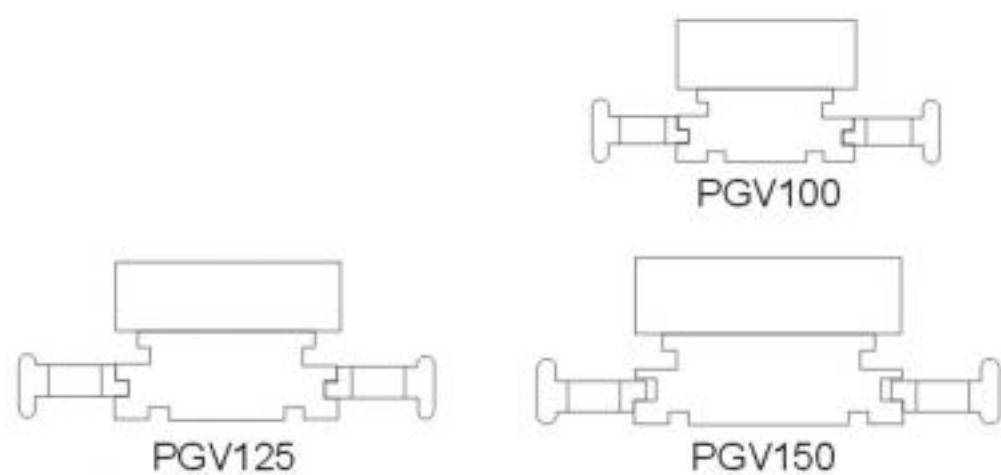

Order No.	Model	A	B	C	D	E	F	G	H	I	J (WxD)	K	L	N.W.
52970-100	PGV100	220	100	80	40	40	40	110	50	M10	9x7	9.5	235	11.1kg
52970-125	PGV125	300	125	90	40	50	60	165	70	M10	11x7	12.5	290	20.6kg
52970-150	PGV150	340	150	95	45	50	60	210	70	M10	12x11	14	340	23.5kg



Gin Tech Precision Co., Ltd. Copyrighted; All Rights Reserved

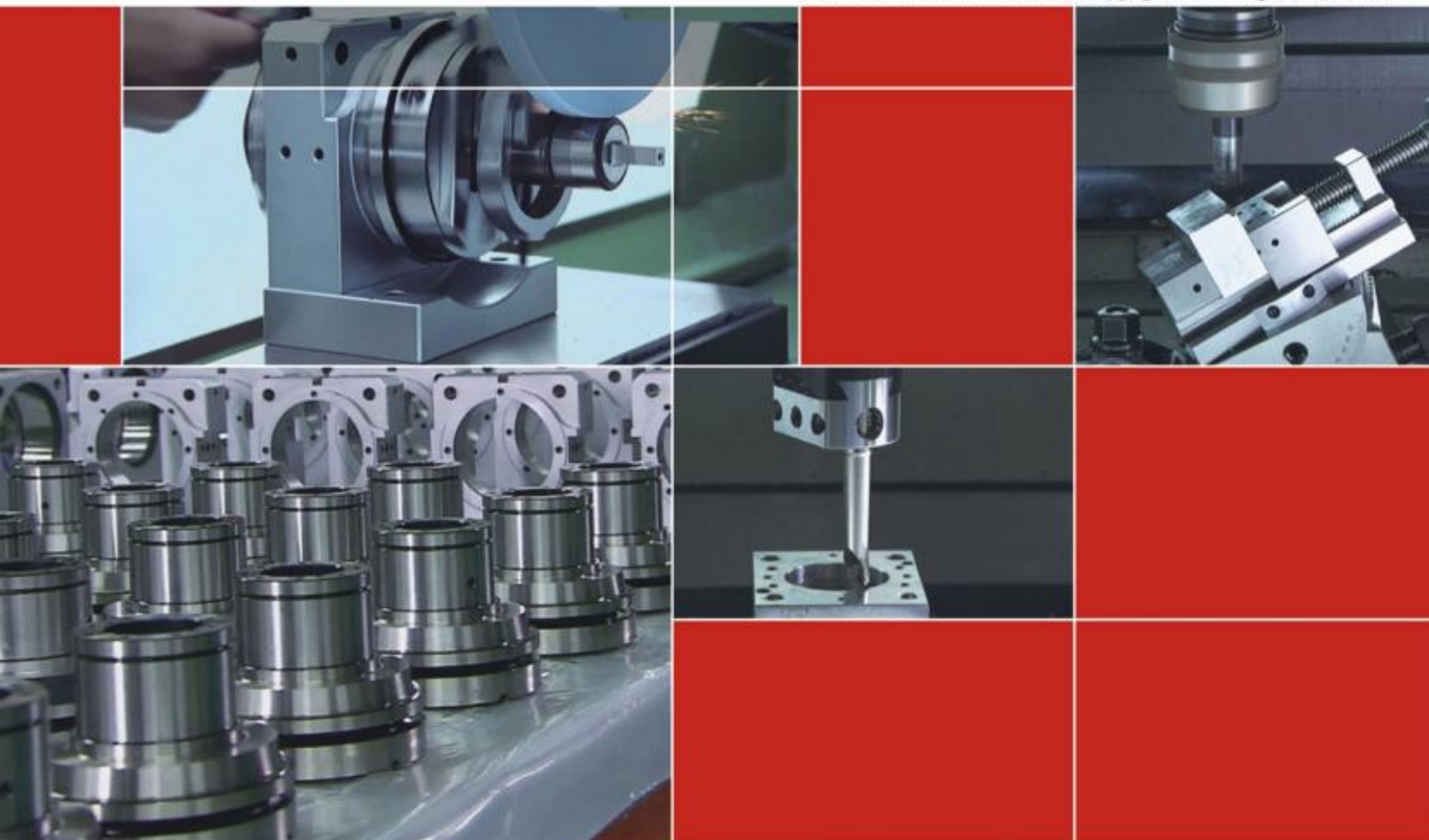

Gin Chan reserves right to amend the product content without prior notice

精展精密科技股份有限公司（總公司）
GIN TECH PRECISION CO.,LTD.

台灣238新北市樹林區保安街一段341巷7號
Address: No 7, Lane 341, Sec. 1, Bau An Street, Shu lin Dist.,
23841, New Taipei City, Taiwan
TEL: 886-2-2681-8596 (Rep.)  Sales@ginchan.com.tw
FAX: 886-2-2681-8516  www.ginchan.com.tw

大陸總經銷
東莞美商精展機械五金有限公司
東莞市精展機械五金有限公司
GIN CHAN MACHINERY & HARDWARE CO.,LTD.(DONGGUAN)

廣東省東莞市大朗鎮石廈村金沙崗二路27號
Tel : 86-769-8318-5858 (Rep.)
Fax: 86-769-8318-5838/8313-5003
 www.ginchan.com.cn  sales@ginchan.com.cn



Scan Now!

