



本目錄內自定心虎鉗及並列式虎鉗均申請有中國、美國、德國、日本專利在案,仿冒必究



專業製造精密機床配件  
全方位展售您要的產品

Workholding Solution Manufacturing

## 公司簡介 Introduction

自1988年成立以來，精展精密科技一直致力於提高生產效率和產品質量，以滿足客戶的需求。經過持續創新及改進，無論在產品多樣性或是質量表現上都能讓精展在市場上具有競爭優勢。

精展主要生產磨床、銑床等工具機配件和模具零配件。因客戶的信賴及支持，更因應客戶的工業4.0自動化的需求而推出【模組化並列式虎鉗】、【自定心虎鉗】、【零點快換板】三個系列產品，提供多種加工夾緊解決方案。領先的技術水平，先進的加工設備，優異、穩定的表現深獲客戶贊譽。

[品質、信用、可靠、專業]是精展堅持貫徹的經營理念，我們懷抱貢獻產業的使命，不斷成長茁壯，用前瞻視野洞悉客戶未來需求，期許以多年的專業經驗與突破性的創新動力，提供更高效率、節能的零配件產品，協助客戶開創未來競爭力，精展總是為您想的更多。

GinTech has been striving making improvement on productivity as well as product quality in order to fulfill customer demands. Constantly innovation and improvement to achieve both product variety coverage and quality which gives competitiveness edge in the market.

For industrial 4.0 and workholding solutions, Modular Clamping System (MKS), 5-axis Self-centering Vise (PQV) and Zero-Point System (EQS) series are hence developed and introduced. Workholding solutions versatily provide leading edge and steady performance for customers' satisfactory.

Quality, Trust, Reliability, Profession, these are the essence for GinTech management. Embracing the contribution to the industry with constant growth as well as vision for further demand in the market. GinTech always think further ahead in the front.

G.M. /



### 加工設備

- CNC 臥式加工中心機 (300 mm 四方工作盤 x 10座)
- CNC 臥式加工中心機 (400 mm 四方工作盤 x 10座)
- CNC 臥式加工中心機 (400 mm 四方工作盤 x 2座)
- CNC 臥式加工中心機 (400 mm 四方工作盤 x 24座)
- CNC 五面加工中心機 (400 mm 四方工作盤 x 2座)
- CNC 五面加工中心機 (300 mm 四方工作盤 x 10座)
- CNC 五軸同動加工中心機 (150 x 150 mm 盤 x 180座)
- CNC 立式加工中心機 (400 x 800 mm 盤)
- CNC 立式加工中心機 (500 x 1000 mm 盤)
- CNC 四軸車銑複合加工機
- CNC 七軸車銑複合加工機
- CNC 九軸車銑複合加工機
- 立式銑床 (2馬力)
- 立式銑床 (1.5馬力)
- CNC 自動車床
- 手動車床
- 無心磨床
- 外圓磨床
- 桌上型內外圓磨床
- CNC 平面磨床
- 手動平面磨床
- 三軸自動平面磨床
- 自動內孔磨床
- CNC 三軸外圓磨床
- CNC 五軸外圓磨床
- CNC 雙軸內孔磨床

# INDEX



**PQV** 零點定位自定心虎鉗  
5-Axis Self-Centering Vise (for EROWA, System-3R)  
搭配 EROWA、3R定位使用 ..... A01~A06



**PQV** 零點定位自定心虎鉗  
5-Axis Self-Centering Vise (for Zero-point System)  
搭配 96 / 52快換基座使用 ..... A07~A20



**EQS** 96 / 52零點方型快換基座  
Zero-Point Plates 96 / 52 ..... B01~B09



**EQR** 96 / 52零點圓型快換基座  
Zero-Point Plates 96 / 52 ..... B10~B14

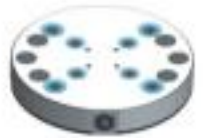

**EQP** 零點96快換三面基座  
Zero-Point Pyramid 96 ..... B15



**EQTB** 零點96 / 52雙面轉向快換基座(立管)  
Zero-Point Twin Base 96 / 52 ..... B16



**EQH** 零點96 / 52五軸虎鉗零點加高座  
Zero-Point Riser 96 / 52 ..... B17~B18



**EQB** 零點連接板底座  
Zero-Point Adaptor Plate ..... B19



**EQE** 零點96轉96 / 52快換連接座(加高型)  
Zero-Point Riser Adaptor ..... B20



**EQA** 零點定位校正及其零點配件  
Zero-Point Accessories ..... B21~B24



**MKS** 模組化並列式虎鉗  
Modular Clamping System ..... C01~C20



## 零點定位快換系統

Mechanical Zero-point system

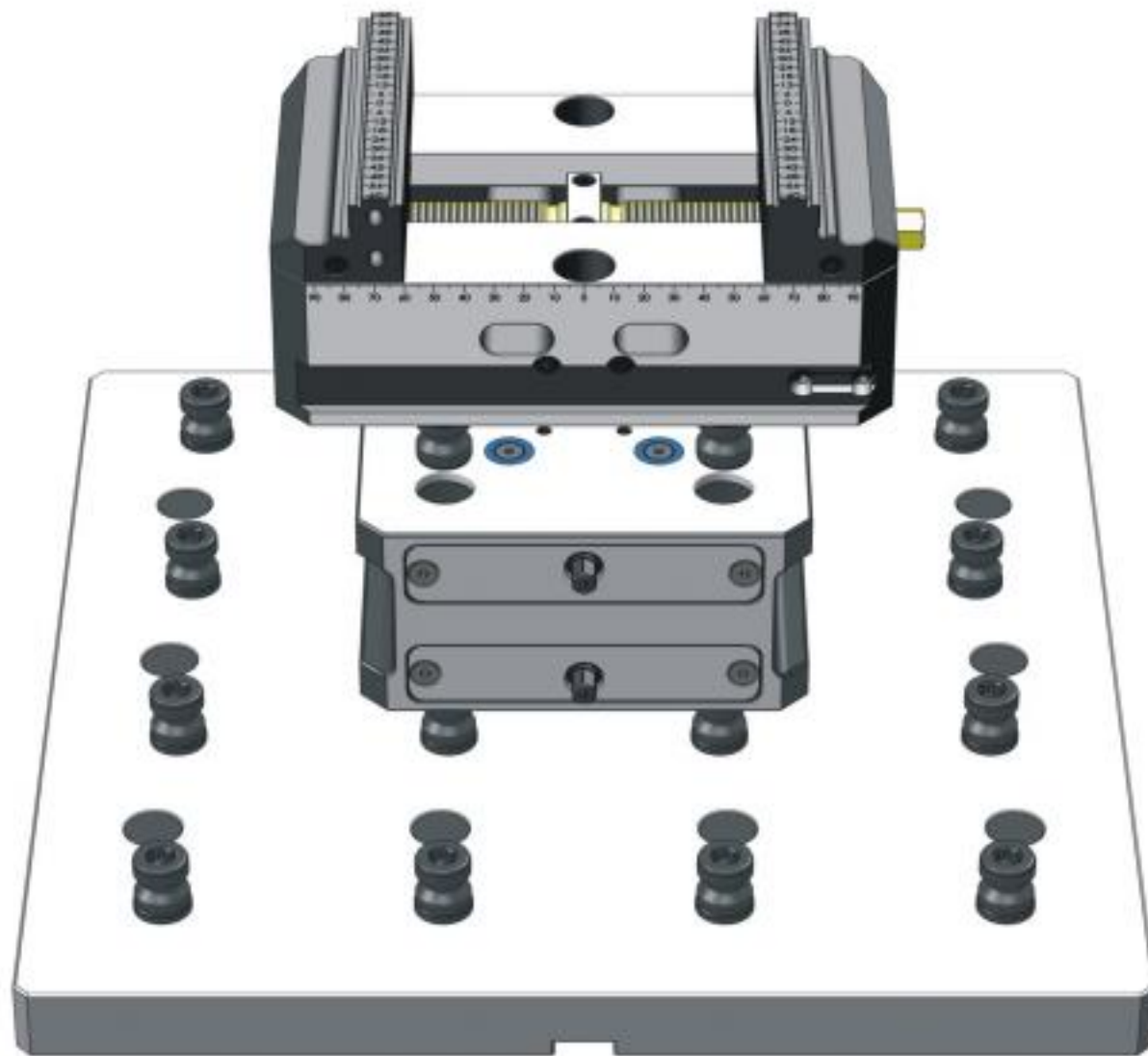

### 零點間距技術概述

這是一個獨特的零點夾緊，和新專利設計的頂出系統。使零點技術更容易，更快，更精確。夾緊與頂出更靈活，更安全，並與任何機器安裝兼容。

### EXQUISITE ZERO-POINT SYSTEM INNOVATION

GIN has succeeded with a new approach to make the zero-point technique even easier, faster and more precise. In addition, It is significantly less cost-intensive, more flexible in application, safer in clamping and compatible with any machine or mounting grid.

### 全系列優化 Optimisation in innovation

**PATENTED**

96與52中心在一個板上  
96 and 52 grid combined in one plate

優化的邊緣，用於安裝在中心槽中  
Optimized flap edge for mounting in the center groove

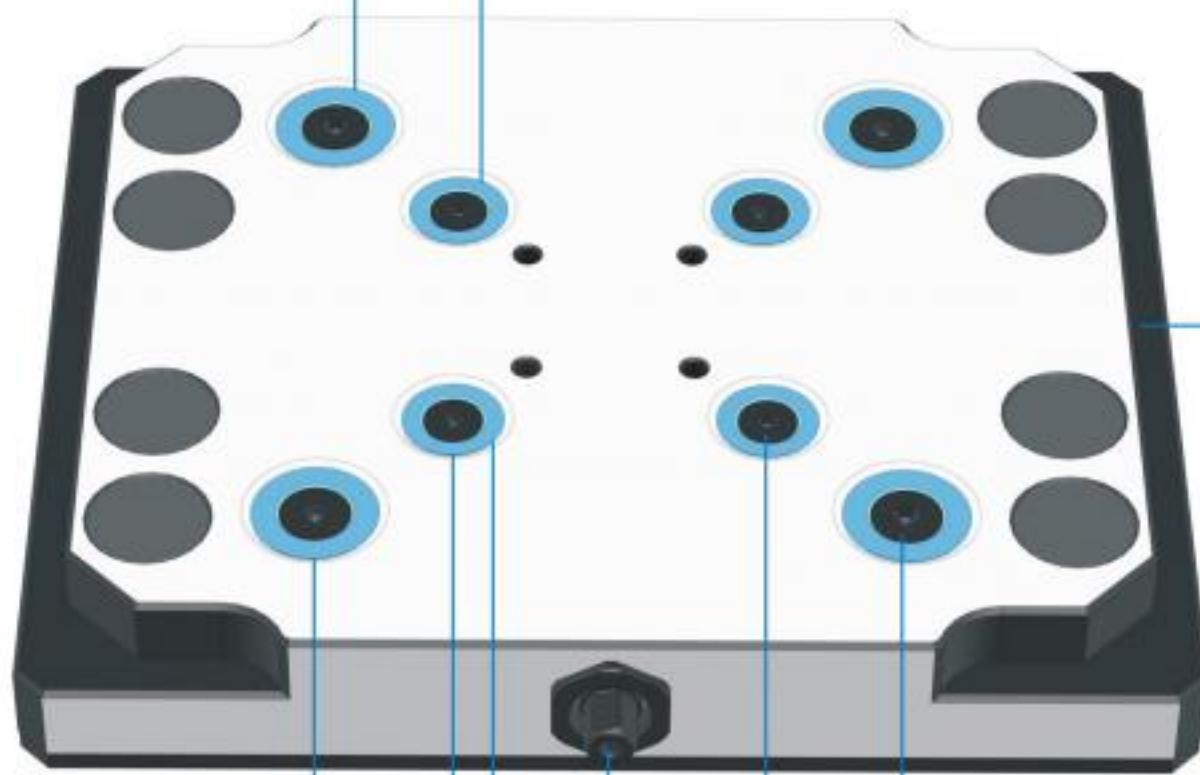

3倍的鎖定力  
3 times higher locking force

定位孔內設計有專利頂出托板，能在六角螺桿鬆開時將虎鉗頂出脫離基礎板

Patent ejection function, when loosen the hex key, the vise will be ejected from the plate.

可利用磁性筆MSB150將防塵塞取下  
The dust plug can be removed using the magnetic pen MSB150

#### 零點技術的快換板

除了夾緊和能快速頂出外，更具有更高的吸合力。也可以在一個板上具有96和52中心的組合板。與同類系統相比，鎖定技術所包含的組件相對簡單。具有3倍更高的鎖定力產生。

#### ZERO-POINT TECHNOLOGY UPGRADED

Zero-Point Plates is a development by GIN which has a significantly higher pull-in force than the systems already on the market, in addition to the established properties. Combination plates with 96 and 52 centres in one plate are also possible. The locking technology also consists of significantly less components than comparable systems. This results in only minimal friction losses and 3 times higher locking force is generated.

## 96 / 52 快換基座

Zero-point plates 96/52

方型快換板

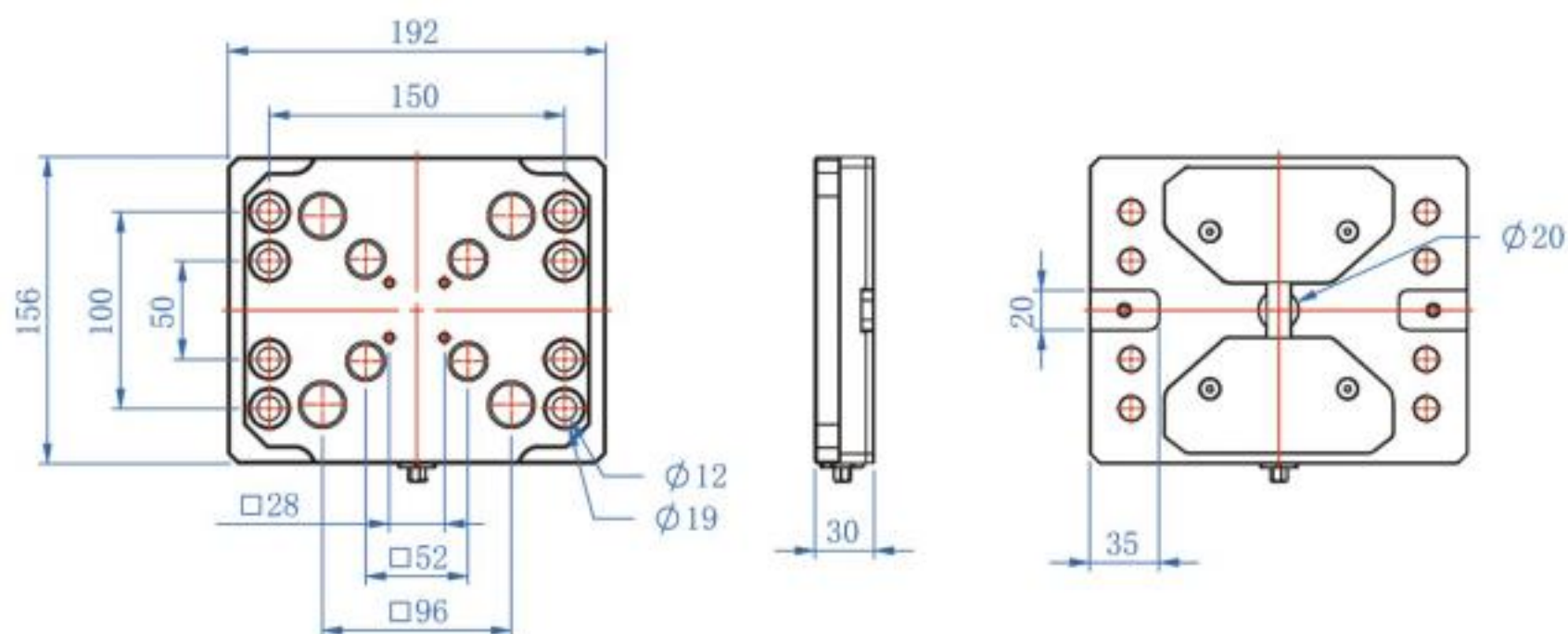
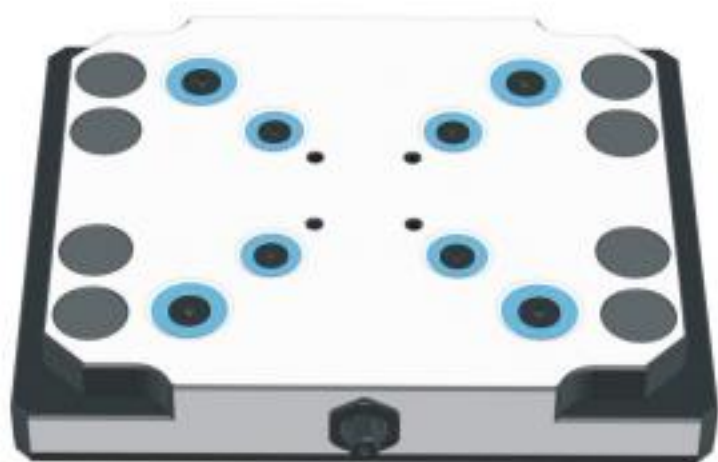

訂購編號 / Order No.		64900
型號 / Model		EQS96/52
尺寸 / Dimensions	mm	192 x 156 x 30
零點系統 / Zero-point system	mm	96 / 52
零點螺栓 / Zero-point bolt	mm	Ø20 / 16
適用虎鉗 / Compatible		PQV77-54 / PQV77-75 / PQV125-75 / PQV125-125
擰緊力矩 / Max. tightening torque	Nm	45
保持力 / Holding force (4 studs)	kN	60
定位精度 / Accuracy	mm	0.005
重量 / Weight	kg	5.5

### 52 快換基座

Zero-point plates 52

方型快換板

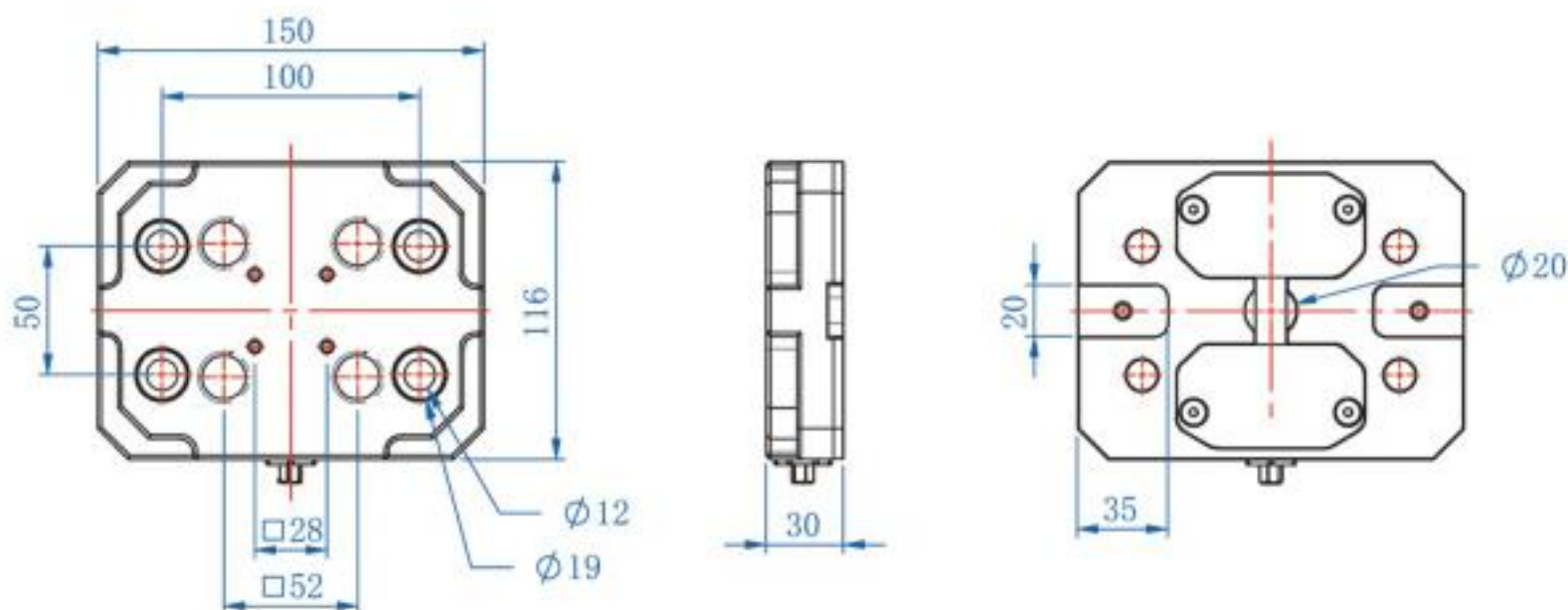

訂購編號 / Order No.

64901

型號 / Model

EQS52

尺寸 / Dimensions

mm

150 x 116 x 30

零點系統 / Zero-point system

mm

52

零點螺栓 / Zero-point bolt

mm

Ø16

適用虎鉗 / Compatible

PQV77-54 / PQV77-75

擰緊力矩 / Max. tightening torque

Nm

45

保持力 / Holding force (4 studs)

kN

60

定位精度 / Accuracy

mm

0.005

重量 / Weight

kg

2.9

**EQS****零點定位系統**

Mechanical Zero-point System

**96 / 52 雙位快換基座**

Double Zero-point plates 96/52

長方型快換板

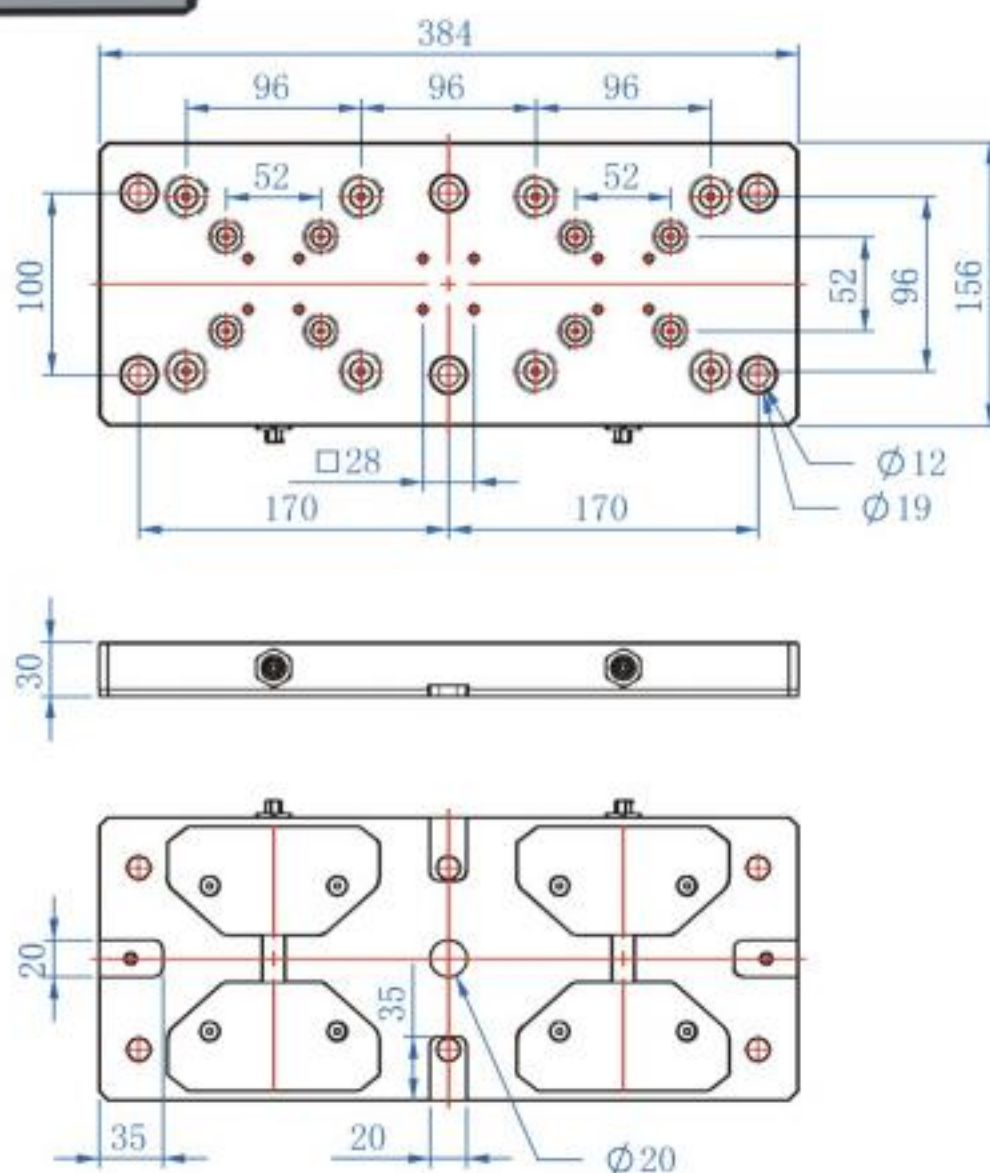

訂購編號 / Order No.		64905
型號 / Model		EQS96/52D
尺寸 / Dimensions	mm	384 x 156 x 30
零點系統 / Zero-point system	mm	96 / 52
零點螺栓 / Zero-point bolt	mm	Ø20 / 16
適用虎鉗 / Compatible		PQV77-54 / PQV77-75 / PQV125-75 / PQV125-125
擰緊力矩 / Max. tightening torque	Nm	45
保持力 / Holding force (4 studs)	kN	60
定位精度 / Accuracy	mm	0.005
重量 / Weight	kg	14.7



## 快換單板 (立柱用)

Zero-point plate

適用於立柱塔，四面治具塔  
Suitable for tombstone on  
horizontal machining center.

 **B07**

立柱用定位母板

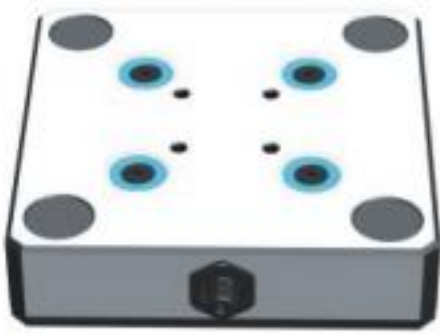

52 快換單板

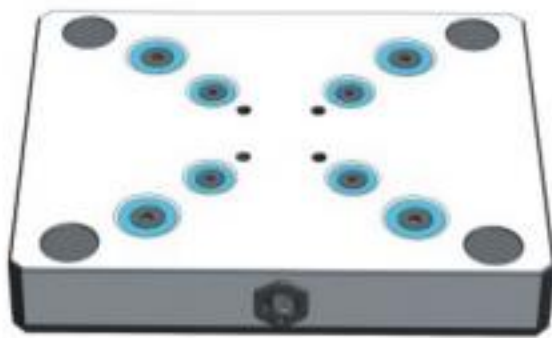
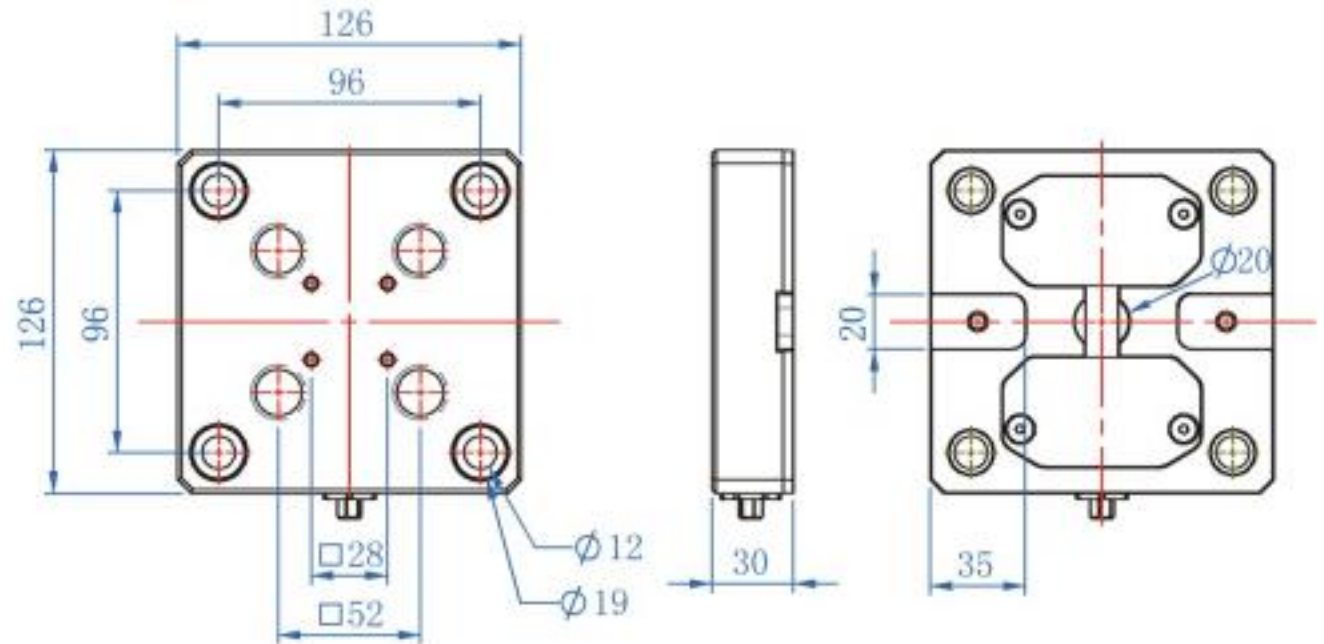

96 / 52 快換單板

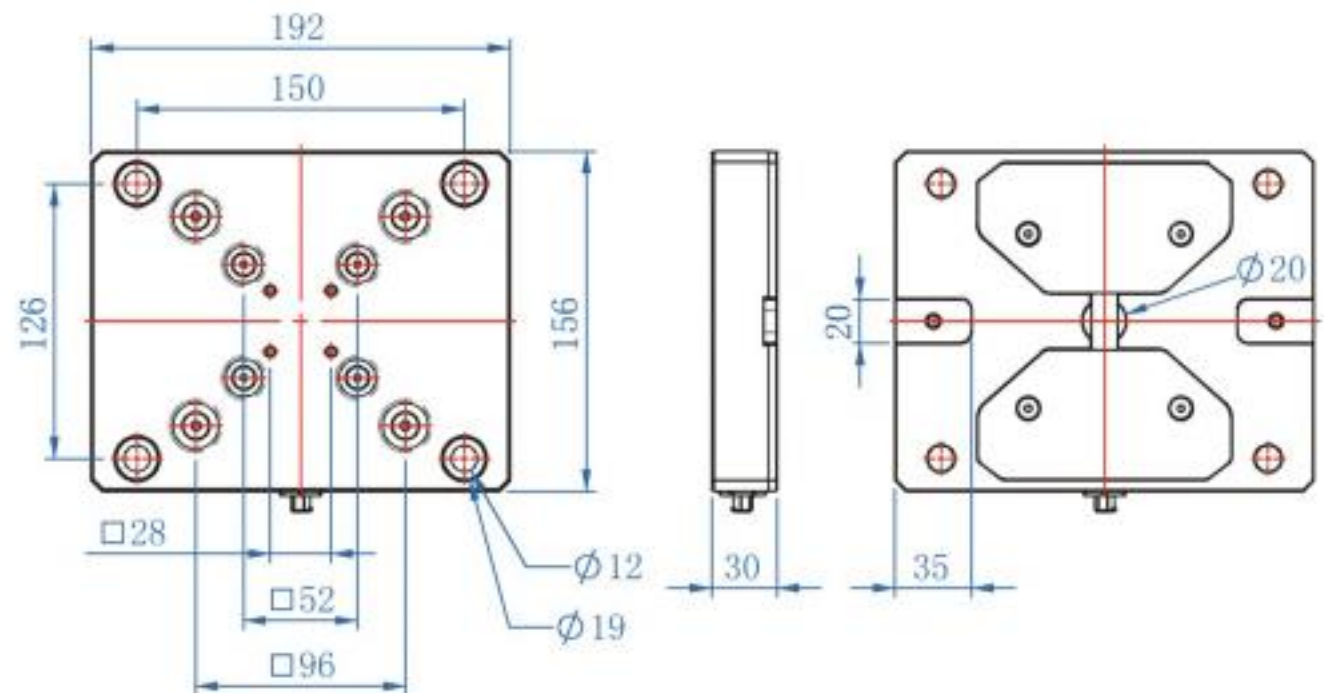

訂購編號 / Order No.		64910	64911
型號 / Model		EQS52T	EQS96/52T
尺寸 / Dimensions	mm	126 x 126 x 30	192 x 156 x 30
零點系統 / Zero-point system	mm	52	96 / 52
零點螺栓 / Zero-point bolt	mm	Ø16	Ø20 / 16
適用虎鉗 / Compatible		PQV77-74 / PQV177-75	PQV77-54 / PQV77-75 PQV125-75 / PQV125-125
擰緊力矩 / Max. tightening torque	Nm		45
保持力 / Holding force (4 studs)	kN		60
定位精度 / Accuracy	mm		0.005
重量 / Weight	kg	2.0	7.0

## 卧式加工立柱

Tombstone for horizontal machining

## 特點

- ▶ 四面立柱、用於組合96/52及96或52的快換板。
- ▶ 穩定的鑄造機體，經精銑加工，平面平行度為0.02mm。
- ▶ 通過零點夾緊系統或直接在機器工作臺上單獨鑽孔模式安裝。

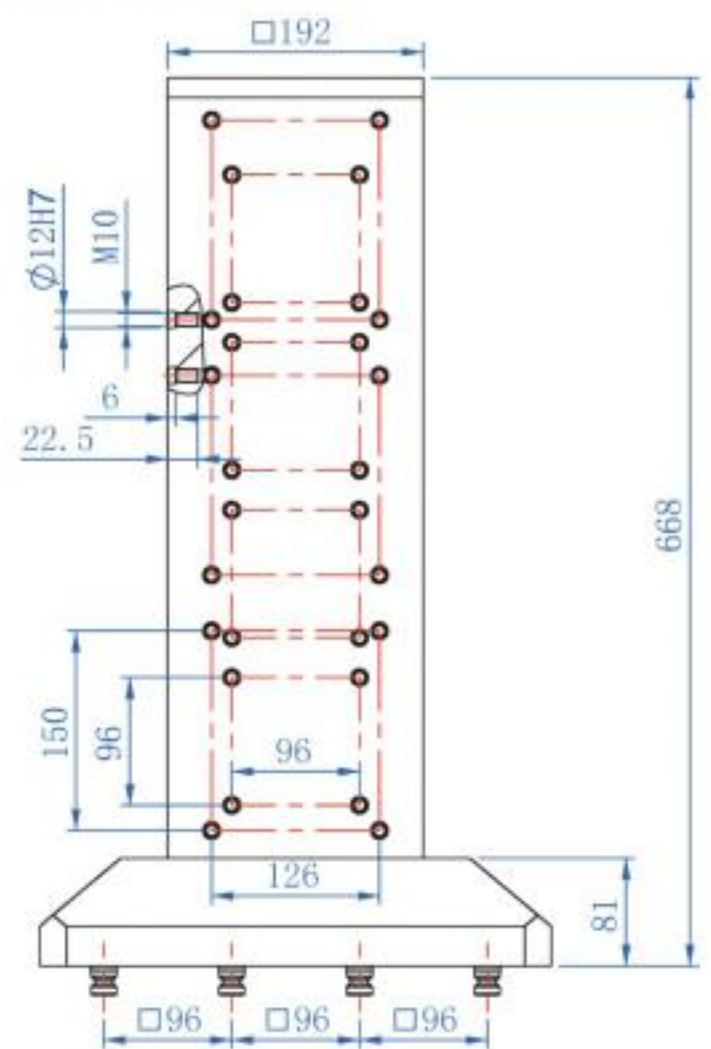
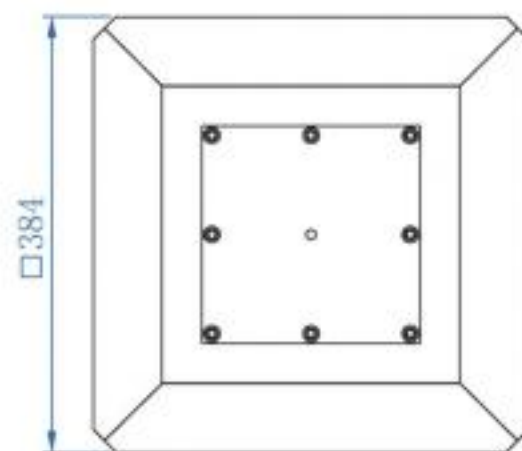
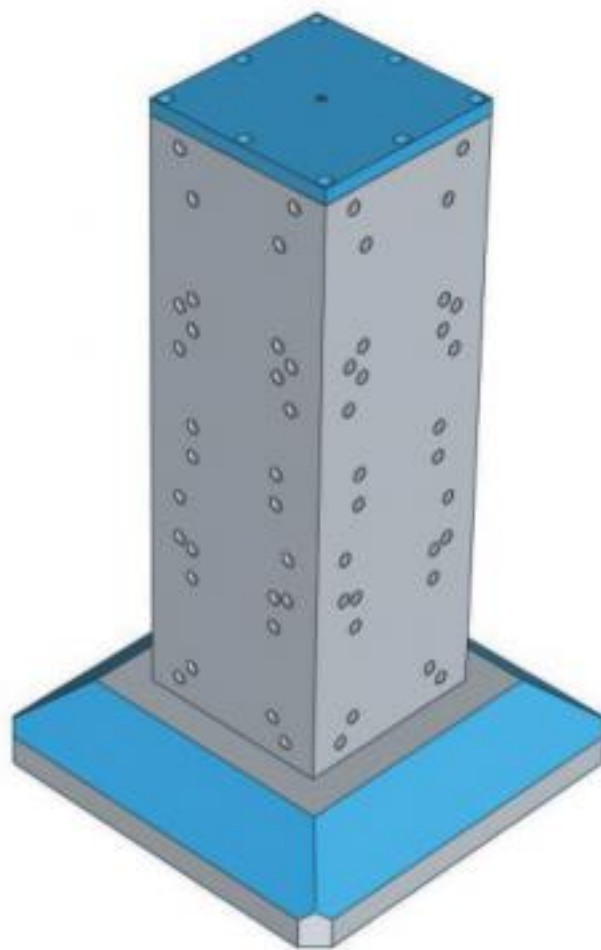

## Features

- ▶ 4-sided tombstone to accommodate combination grid 96/52, 96 or 52mm grid plates.
- ▶ Stable cast base body, fine milled with a plane parallelism of 0.02mm.
- ▶ Mounting via Zero-point clamping system or by individual drilling pattern directly on the machine table.

訂購編號 / Order No.

64909

型號 / Model

EQT668

尺寸 / Dimensions

mm

384 x 384 x 668

零點系統 / Zero-point system

mm

96

零點螺栓 / Zero-point bolt

mm

Ø20

適用虎鉗 / Compatible

PQV77-54 / PQV77-75 / PQV125-75 / PQV125-125

重量 / Weight

kg

169

**EQT**

# 零點定位系統

Mechanical Zero-point System

## 卧式加工立柱

Tombstone for horizontal machining

卧式加工中心的零點夾緊系統

### 應用實例 Applications

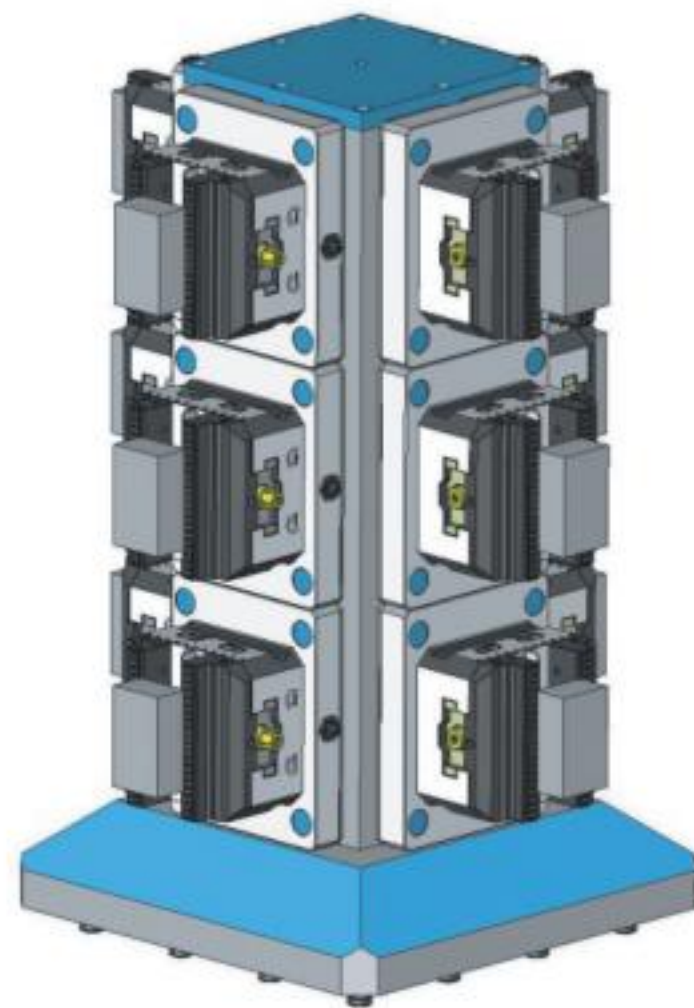
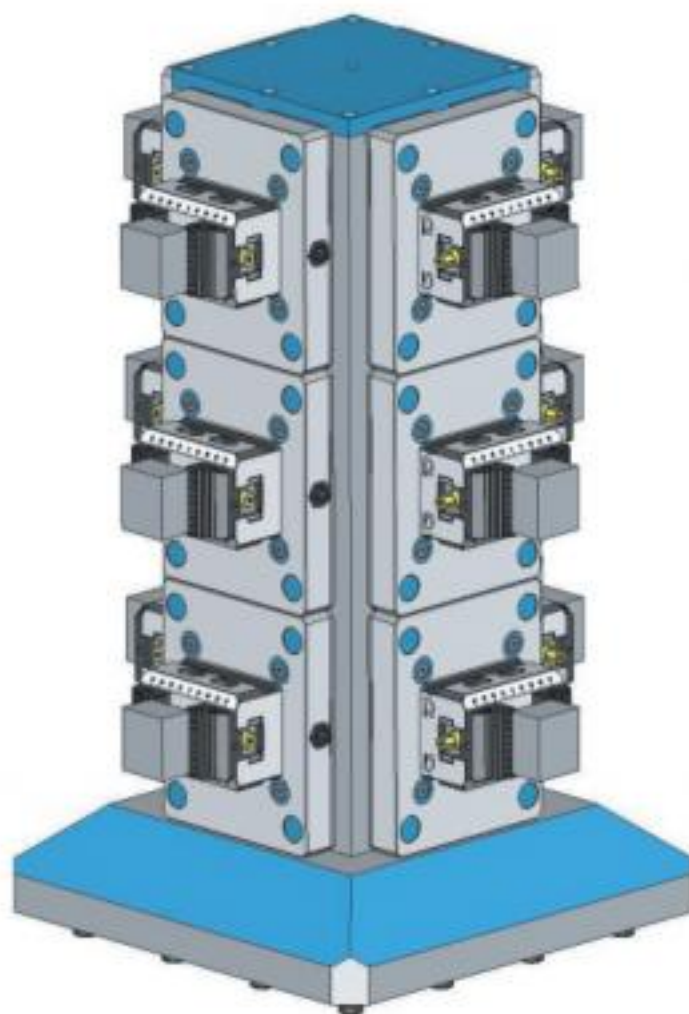
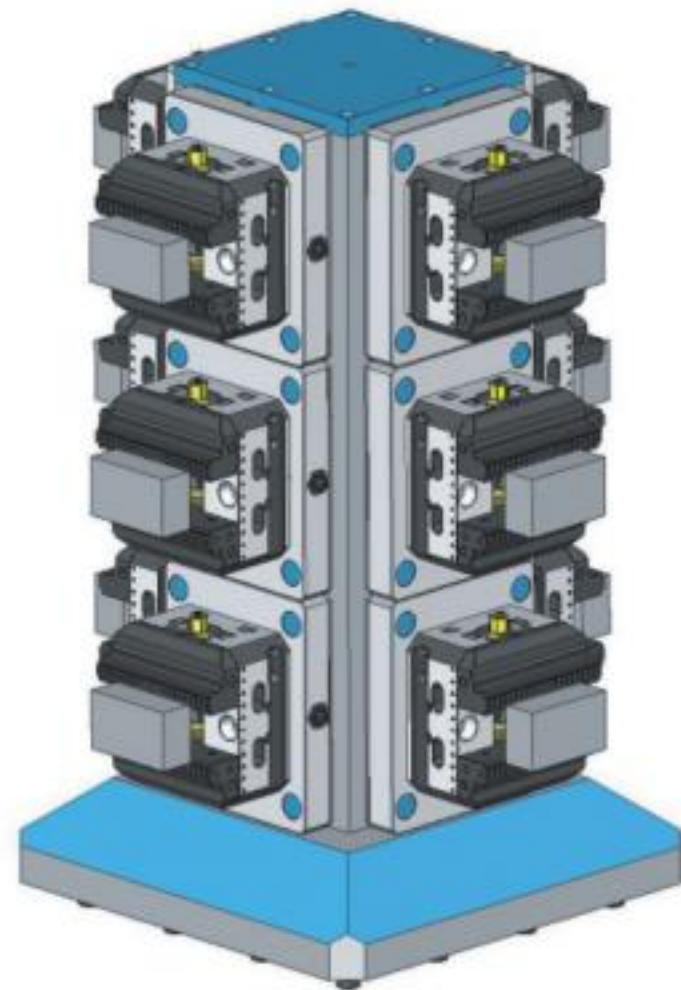
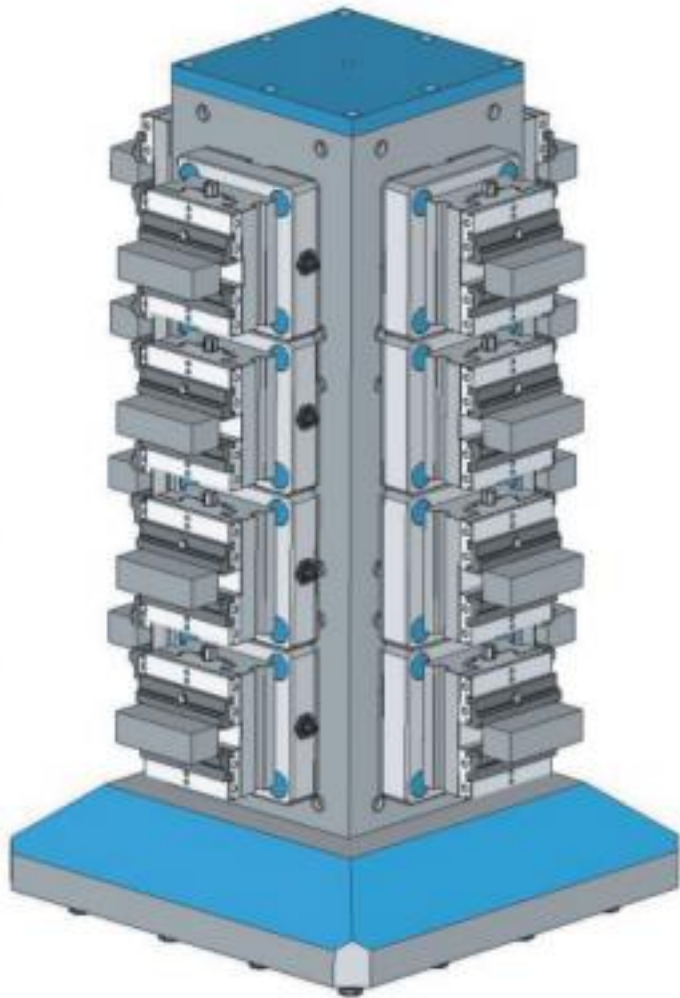

## 96 轉 52 快換基座

Adaptor plate 96 to 52

方型快換轉接板

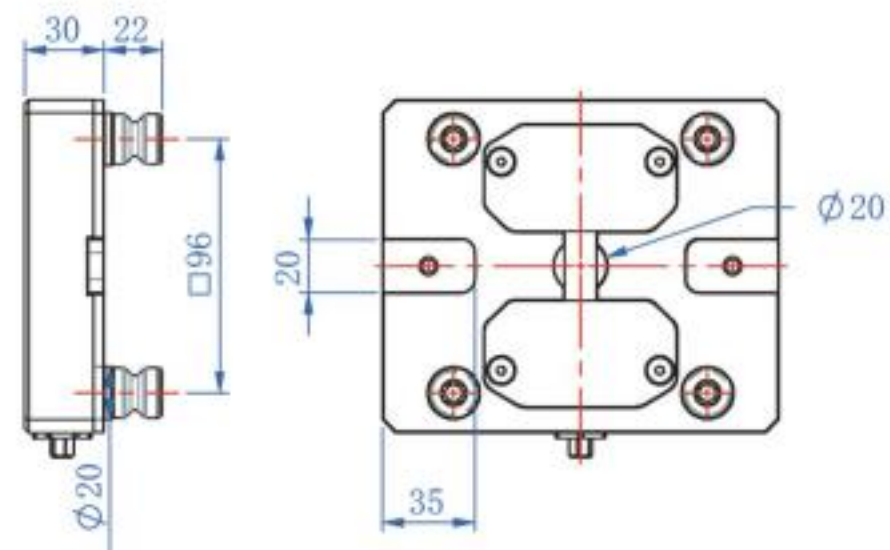
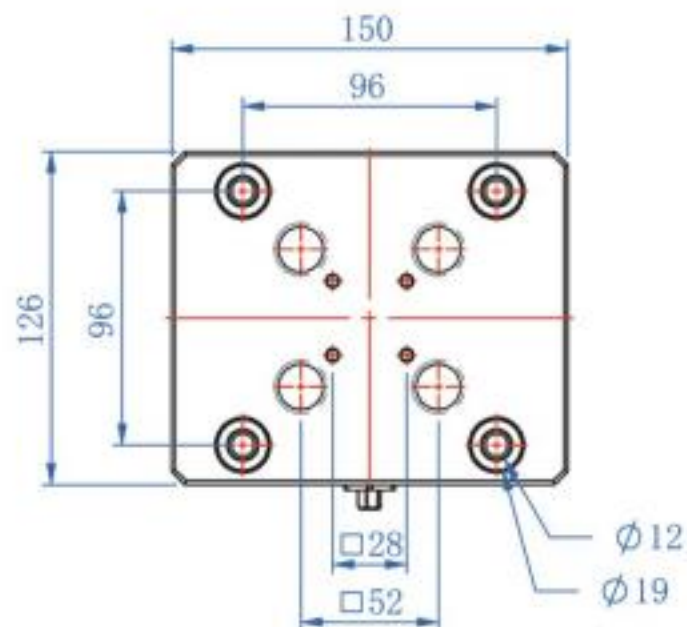
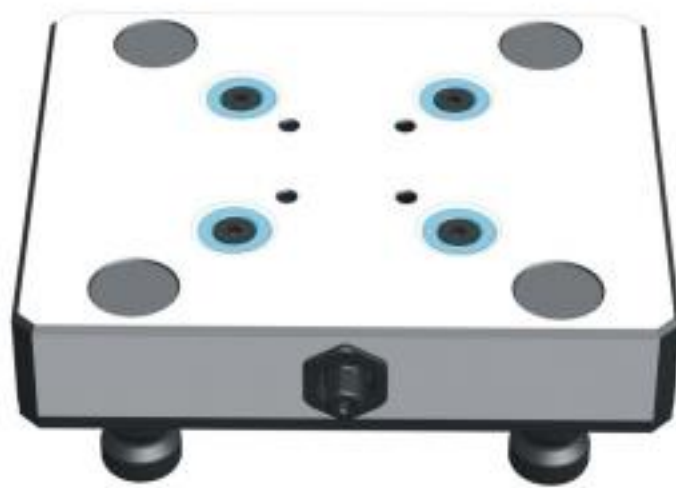

訂購編號 / Order No.		64912
型號 / Model		EQS96-52
尺寸 / Dimensions	mm	150 x 126 x 30
零點系統 / Zero-point system	mm	96 / 52
零點螺栓 / Zero-point bolt	mm	Ø16
適用虎鉗 / Compatible		PQV77-54 / PQV77-75
擰緊力矩 / Max. tightening torque	Nm	45
保持力 / Holding force (4 studs)	kN	60
定位精度 / Accuracy	mm	0.005
重量 / Weight	kg	3.4

### 零點定位三爪轉接板

Zero-point flange plate for jaw chuck

#### 圓型三爪轉接板

5" 三爪轉接板  
5" Flange plate

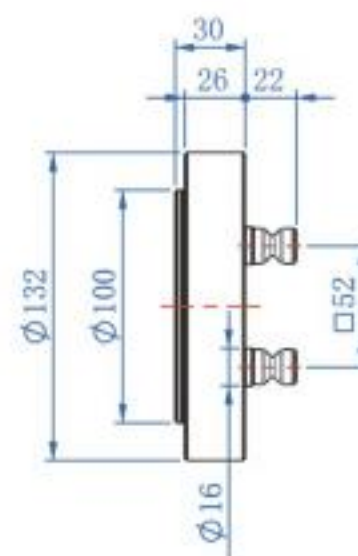
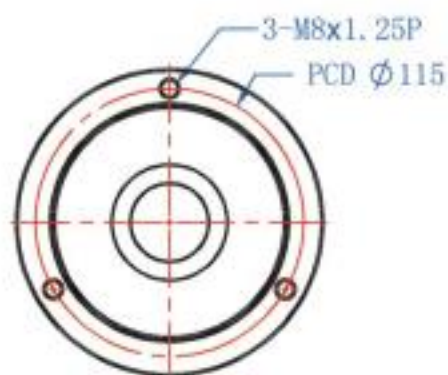

6" 三爪轉接板  
6" Flange plate

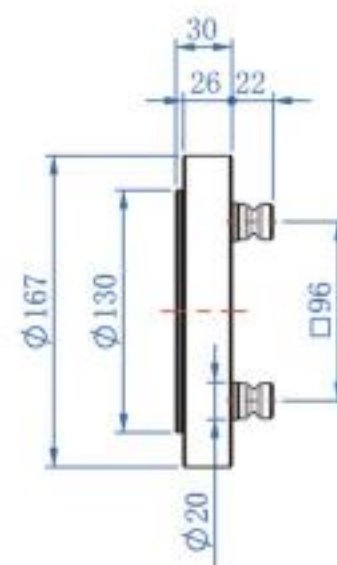
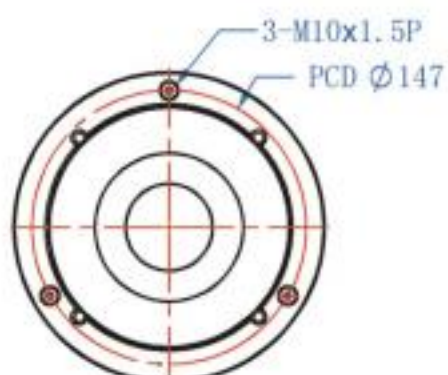

訂購編號 / Order No.		64915	64916
型號 / Model		EQR5	EQR6
尺寸 / Dimensions	mm	Ø132x30	Ø167x30
零點系統 / Zero-point system	mm	52	96
零點螺栓 / Zero-point bolt	mm	Ø16	Ø20
孔位模式 / Hole pattern		Ø115	Ø147
重量 / Weight	kg	3.3	5.3

## 52 快換基座 (圓型)

Zero-point plate 52

圓型快換板(含壓板邊)

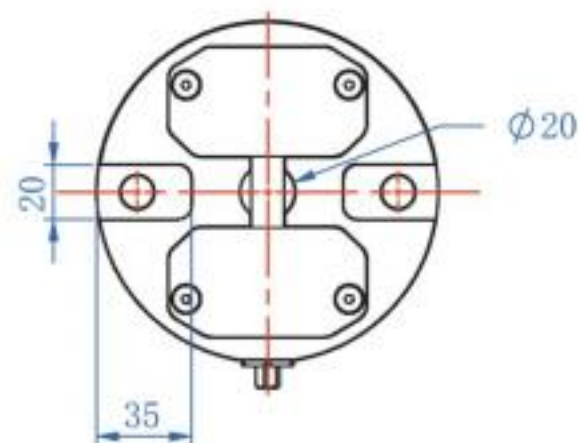
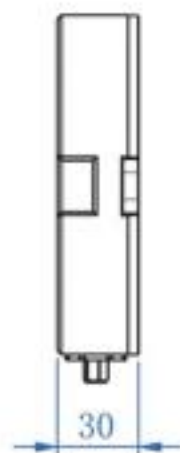
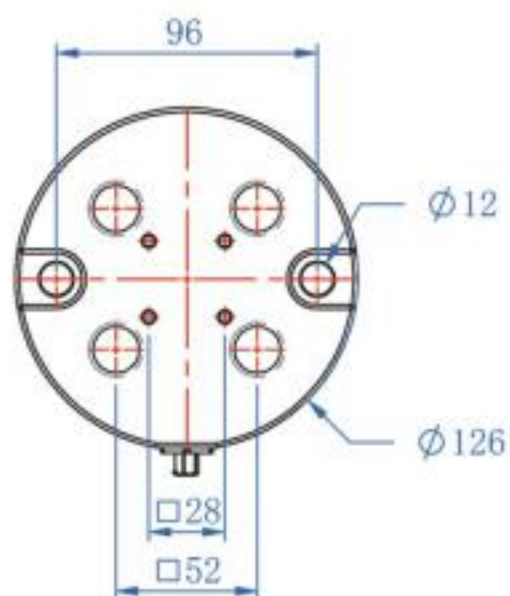
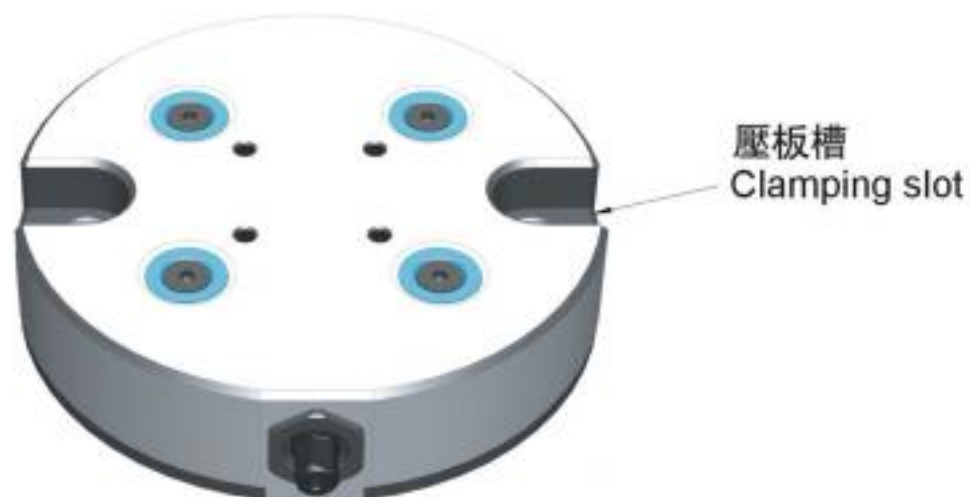

訂購編號 / Order No.		64920
型號 / Model		EQR52
尺寸 / Dimensions	mm	Ø126 x30
零點系統 / Zero-point system	mm	52
零點螺栓 / Zero-point bolt	mm	Ø16
適用虎鉗 / Compatible		PQV77-54 / PQV77-75
擰緊力矩 / Max. tightening torque	Nm	45
保持力 / Holding force (4 studs)	kN	60
定位精度 / Accuracy	mm	0.005
重量 / Weight	kg	1.9

## 96 / 52 快換基座 (圓型)

Zero-point plate 96/52

圓型快換板(含安裝孔)

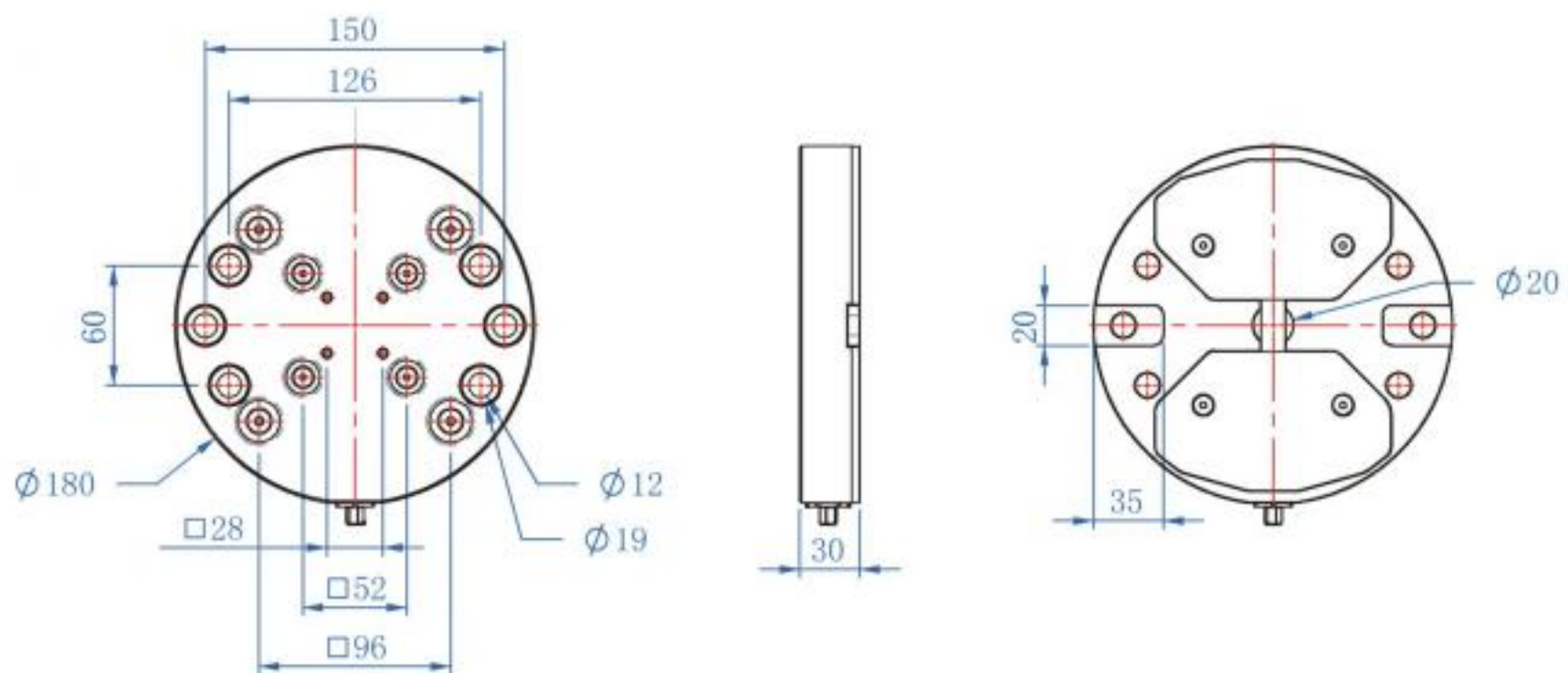
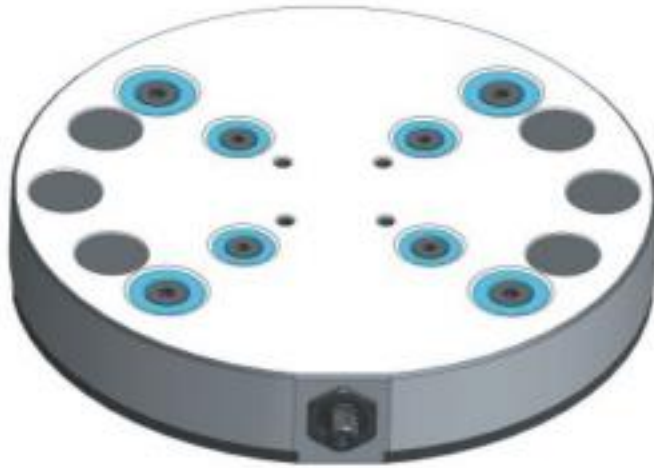

訂購編號 / Order No.

64921

型號 / Model

EQR96/52

尺寸 / Dimensions

mm

Ø180 x30

零點系統 / Zero-point system

mm

96 / 52

零點螺栓 / Zero-point bolt

mm

Ø20 / 16

適用虎鉗 / Compatible

PQV77-54 / PQV77-75 / PQV125-75 / PQV125-125

擰緊力矩 / Max. tightening torque

Nm

45

保持力 / Holding force (4 studs)

kN

60

定位精度 / Accuracy

mm

0.005

重量 / Weight

kg

4.7

### 96 轉 52 快換基座 (圓型)

Adaptor plate 96 to 52

圓型快換轉接板

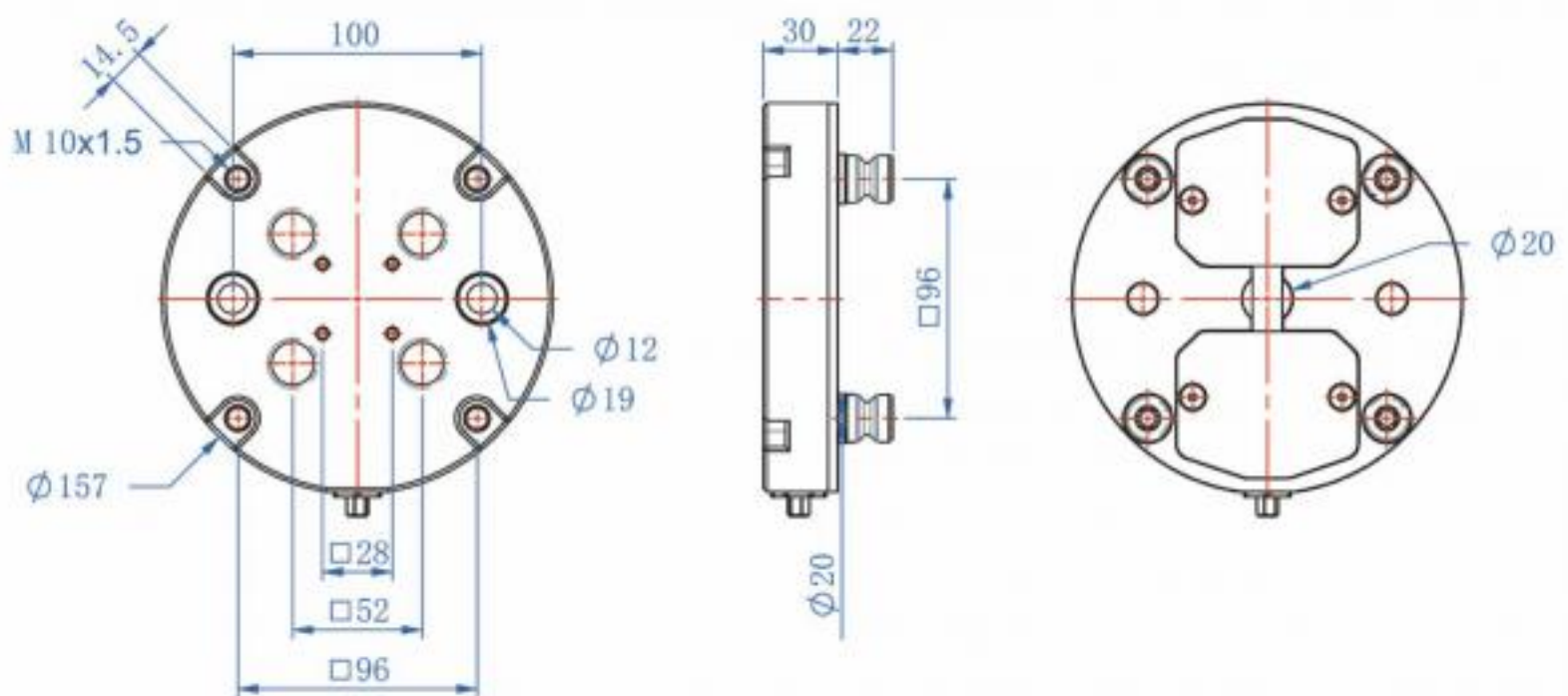
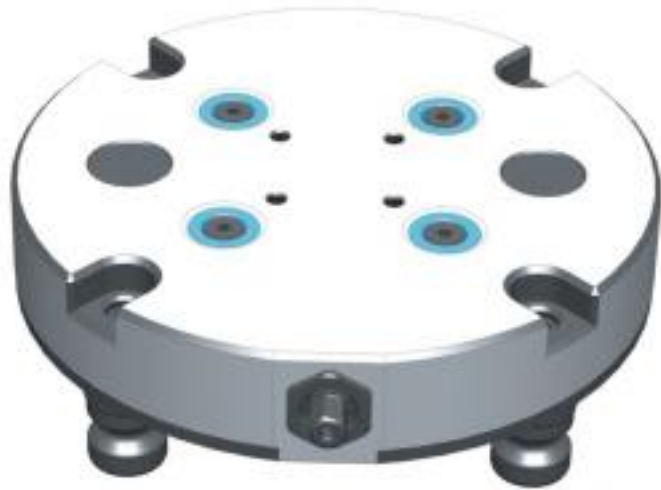

訂購編號 / Order No.	64922	
型號 / Model	EQR96-52	
尺寸 / Dimensions	mm	Ø157 x 30
零點系統 / Zero-point system	mm	96 / 52
零點螺栓 / Zero-point bolt	mm	Ø16
適用虎鉗 / Compatible	PQV77-54 / PQV77-75	
擰緊力矩 / Max. tightening torque	Nm	45
保持力 / Holding force (4 studs)	kN	60
定位精度 / Accuracy	mm	0.005
重量 / Weight	kg	3.7



## 96 快換基座 (快換圓型加高座)

Zero-point riser 96

圓型墊高板60mm/100mm

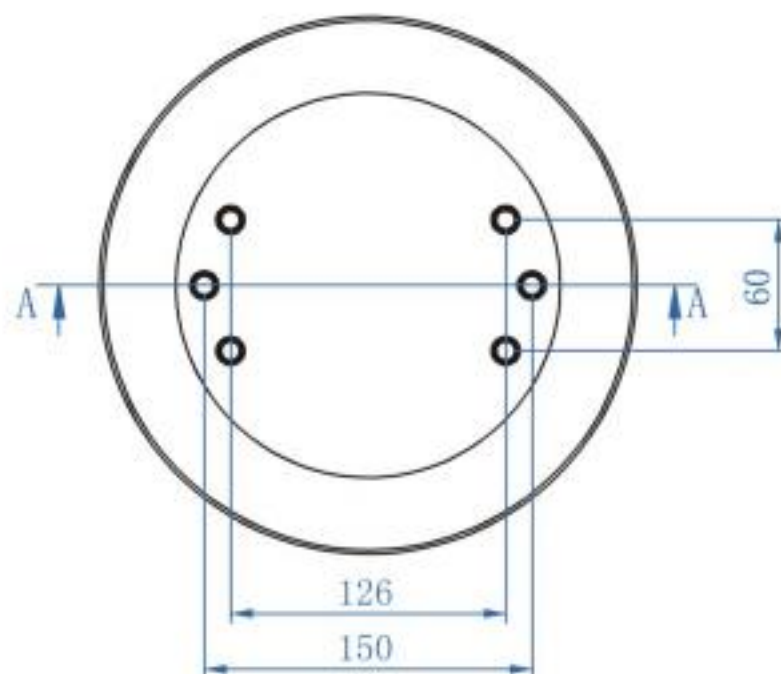

使用示意圖：(此產品含EQR96 / 52)  
Application: (EQR96 / 52 is included)

B12

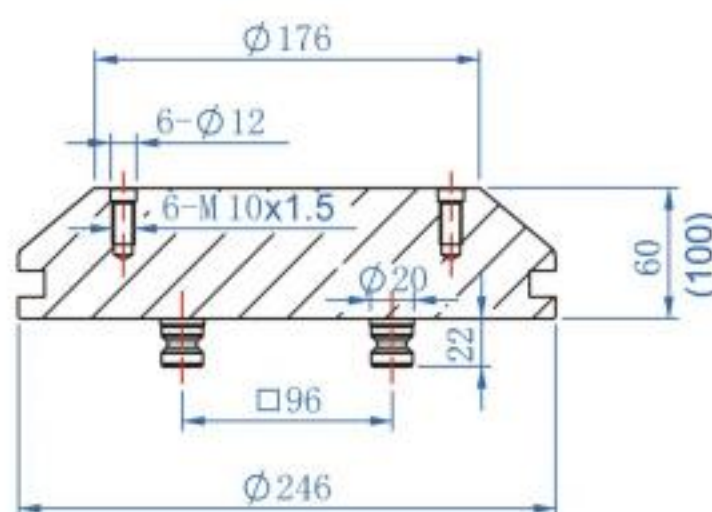
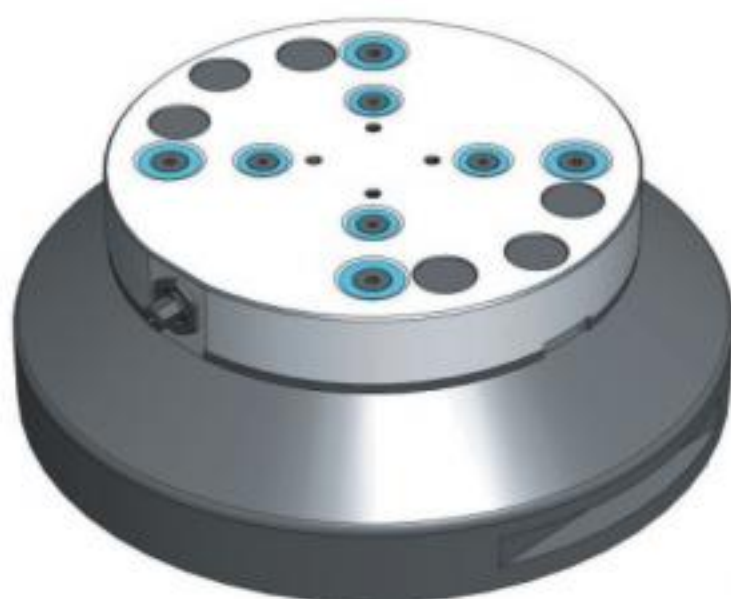

剖面圖 A-A

訂購編號 / Order No.		64925-060	64925-100
型號 / Model		EQR060	EQR100
尺寸 / Dimensions	mm	Ø 246 x 60	Ø 246 x 100
零點系統 / Zero-point system	mm	96	96
零點螺栓 / Zero-point bolt	mm	Ø 20	Ø 20
定位精度 / Accuracy	mm	0.005	0.005
重量 / Weight	kg	11.3	16.5

## 快換3面基座 (含圓型快換基座)

Zero-point pyramid

用於五軸加工中心



## 特點 Features

- ▲ 提高5軸機床的運行時間，並節省安裝時間。  
Increasing machining hours and saving set up time in 5-axis machines.
- ▲ 設計緊湊，鋁合金材質。  
Compactness in design, made of aluminium.
- ▲ 已包含EQR96 / 52快換基座  **B12**  
EQR96/52 are included.

## 使用示意圖 Application:

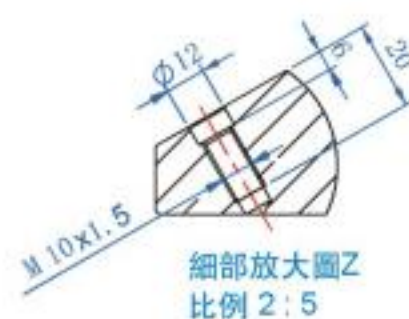
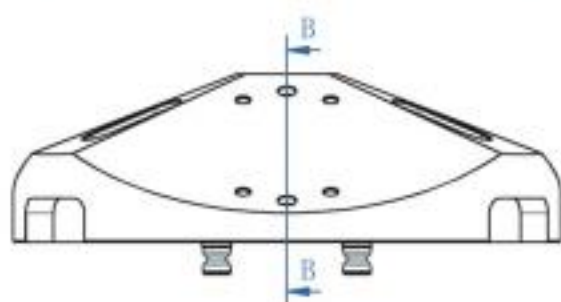
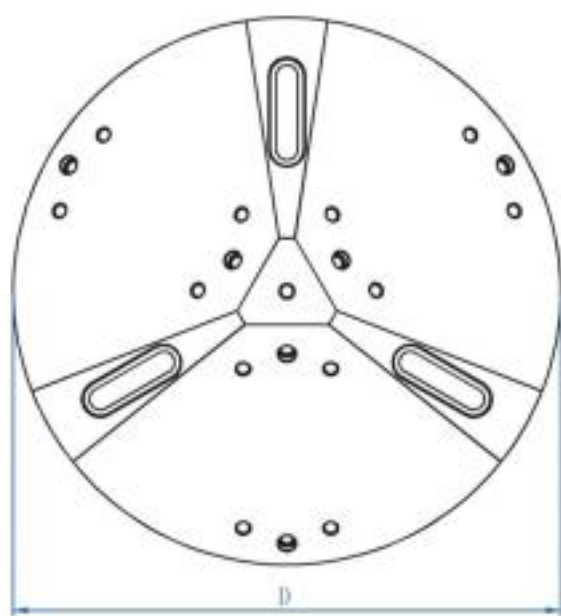
細部放大圖Z  
比例 2:5

訂購編號 / Order No.		64926-310	64926-375	64926-425
型號 / Model		EQP96/52-310	EQP96/52-375	EQP96/52-425
尺寸 / Dimensions	mm	Ø310	Ø375	Ø425
高度 / Dimensions(D)	mm	125	115	100
角度 / Angle(A)		40°	30°	20°
零點系統 / Zero-point system	mm		96 / 52	
零點螺栓 / Zero-point bolt	mm		Ø20 / 16	
適用虎鉗 / Compatible		PQV77-54 / PQV77-75 / PQV125-75 / PQV125-125		
定位精度 / Accuracy	mm	0.005		
重量 / Weight	kg	29.5	36.2	41.3

### 96 / 52 立管 (雙面轉向快換基座)

Twin base 96 / 52

淬火和磨削的雙基座是用3軸機床製造5軸零件的理想選擇。工件可安全定位4x90°，重複精度高。

With zero-point, twin base is suitable for 3-axis machining center to produce workpeice where originally shall be produced by 5-axis machine.

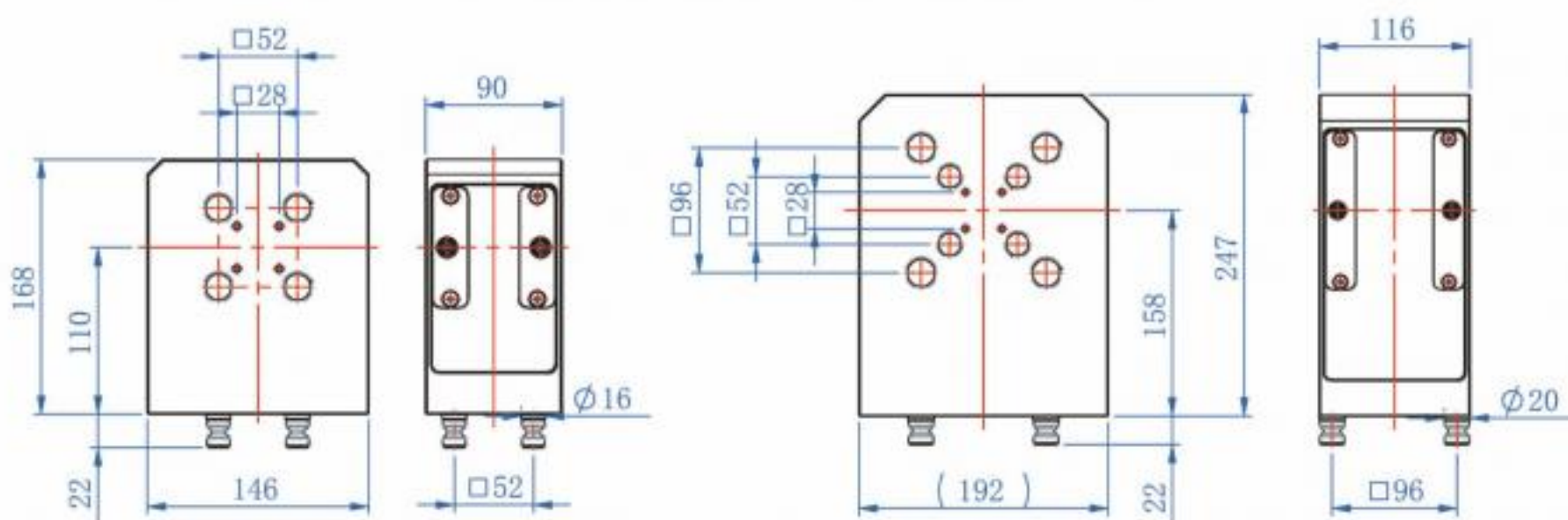

訂購編號 / Order No.		64927	64928
型號 / Model		EQTB52	EQTB96/52
尺寸 / Dimensions	mm	146 x 168 x 90	192 x 247 x 116
零點系統 / Zero-point system	mm	52	96 / 52
零點螺栓 / Zero-point bolt	mm	Ø16	Ø20 / 16
適用虎鉗 / Compatible		PQV77-54 / PQV77-75	PQV77-54 / PQV77-75 PQV125-75 / PQV125-125
擰緊力矩 / Max. tightening torque	Nm	45	45
保持力 / Holding force (4 studs)	kN	60	60
定位精度 / Accuracy	mm	0.005	0.005
重量 / Weight	kg	14.1	35.2

**EQH****零點定位系統****Mechanical Zero-point System****5軸虎鉗零點加高座**

5-axis riser with zero-point 52

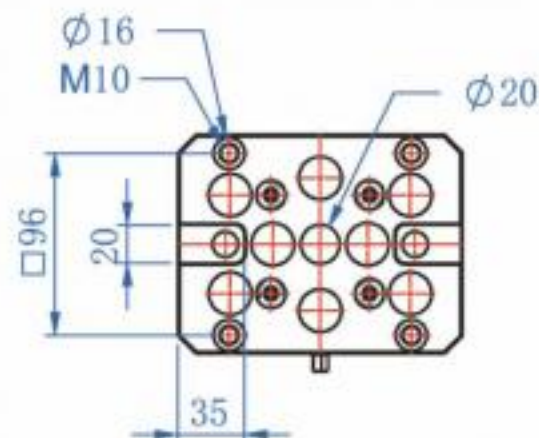
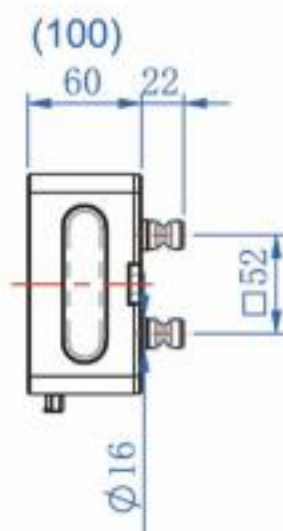
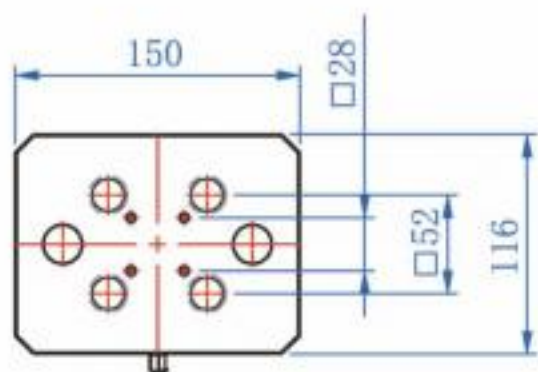

訂購編號 / Order No.		64930-060	64930-100
型號 / Model		<b>EQH52060</b>	<b>EQH52100</b>
尺寸 / Dimensions	mm	150 x 116 x 60	150 x 116 x 100
零點系統 / Zero-point system	mm	52	52
零點螺栓 / Zero-point bolt	mm	Ø16	Ø16
適用虎鉗 / Compatible		PQV77-54 / PQV77-75	PQV77-54 / PQV77-75
擰緊力矩 / Max. tightening torque	Nm	45	45
保持力 / Holding force (4 studs)	kN	60	60
定位精度 / Accuracy	mm	0.005	0.005
重量 / Weight	kg	6.8	11.2

## 5軸虎鉗零點加高座

5-axis riser with zero-point 96/52

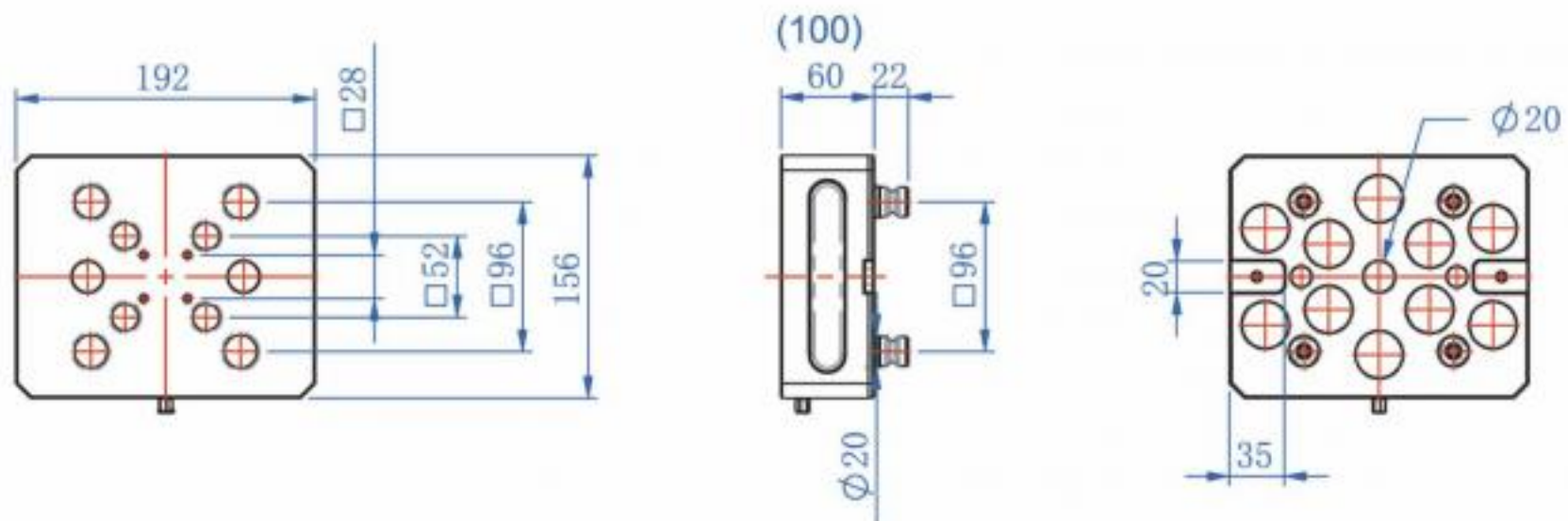

訂購編號 / Order No.		64932-060	64932-100
型號 / Model		EQH96060	EQH96100
尺寸 / Dimensions	mm	192 x 156 x 60	192 x 156 x 100
零點系統 / Zero-point system	mm	96 / 52	96 / 52
零點螺栓 / Zero-point bolt	mm	Ø20 / 16	Ø20 / 16
適用虎鉗 / Compatible		PQV77-54 / PQV77-75 PQV125-75 / PQV125-125	PQV77-54 / PQV77-75 PQV125-75 / PQV125-125
擰緊力矩 / Max. tightening torque	Nm	45	45
保持力 / Holding force (4 studs)	kN	60	60
定位精度 / Accuracy	mm	0.005	0.005
重量 / Weight	kg	11.0	18.2

## 連接座底板

Zero-point flange plates 96

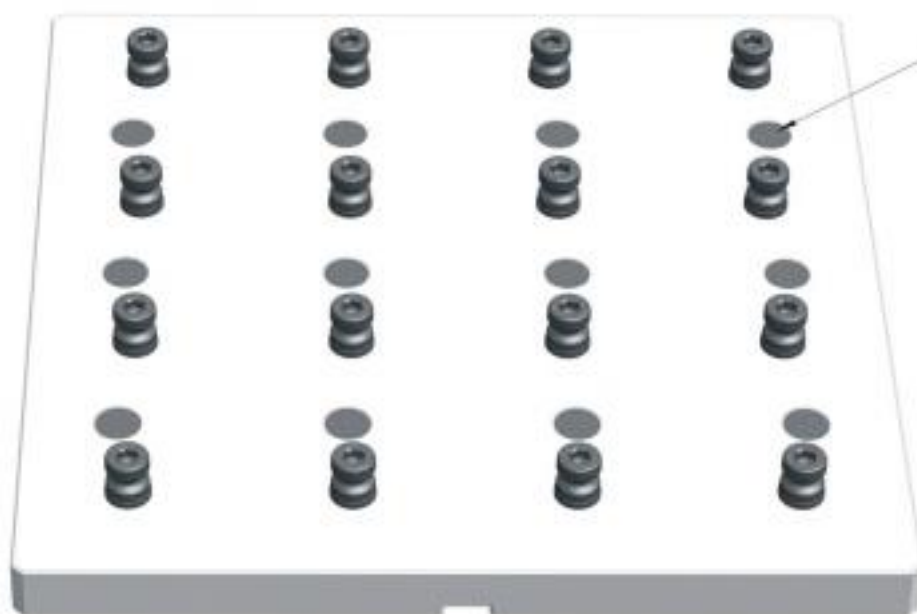

適用於各類機床固定孔。  
Compatible with various machine table.

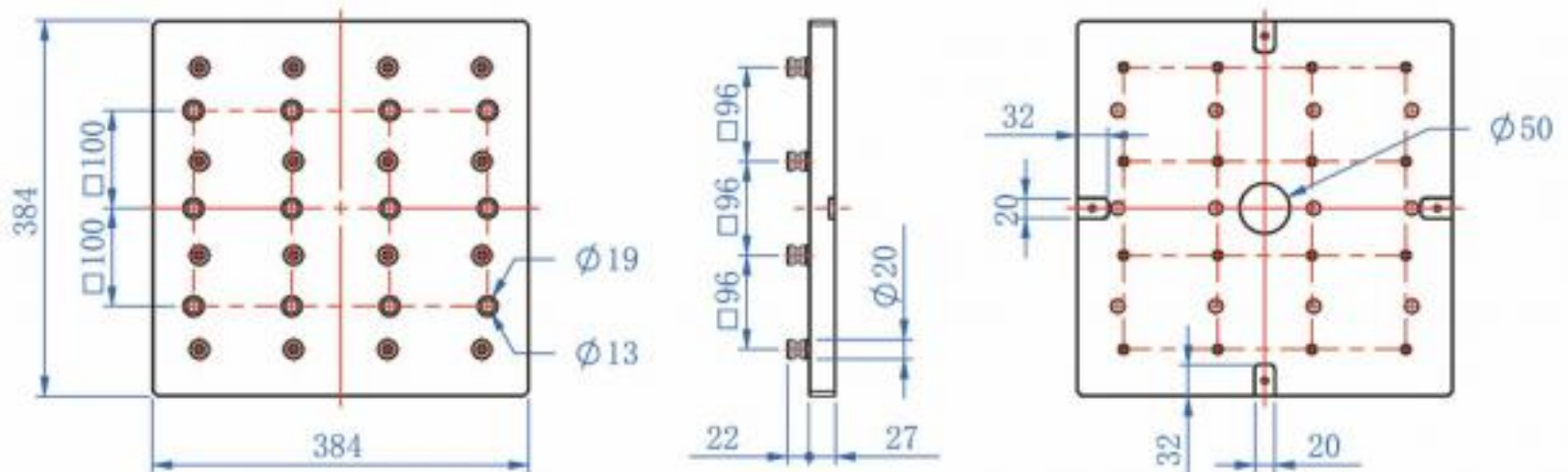

訂購編號 / Order No.		64935
型號 / Model		EQB1515
尺寸 / Dimensions	mm	384 x 384 x 27
零點系統 / Zero-point system	mm	96
零點螺栓 / Zero-point bolt	mm	Ø 20
孔位模式 / Hole pattern		100
重量 / Weight	kg	31.4

**EQE****零點定位系統**

Mechanical Zero-point System

**96 轉 96 / 52 快換連接座 (加高用)**

5-axis riser flange plate 96/52

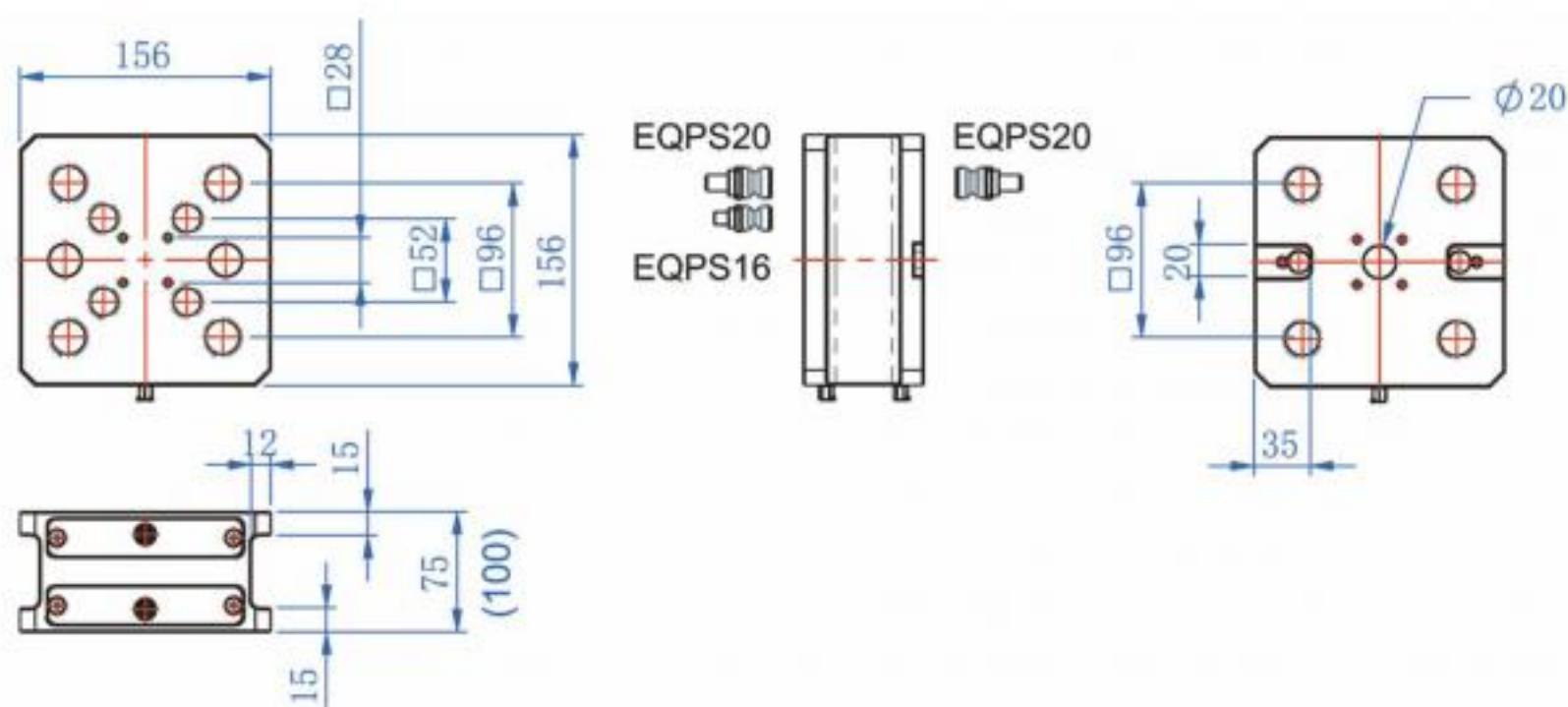
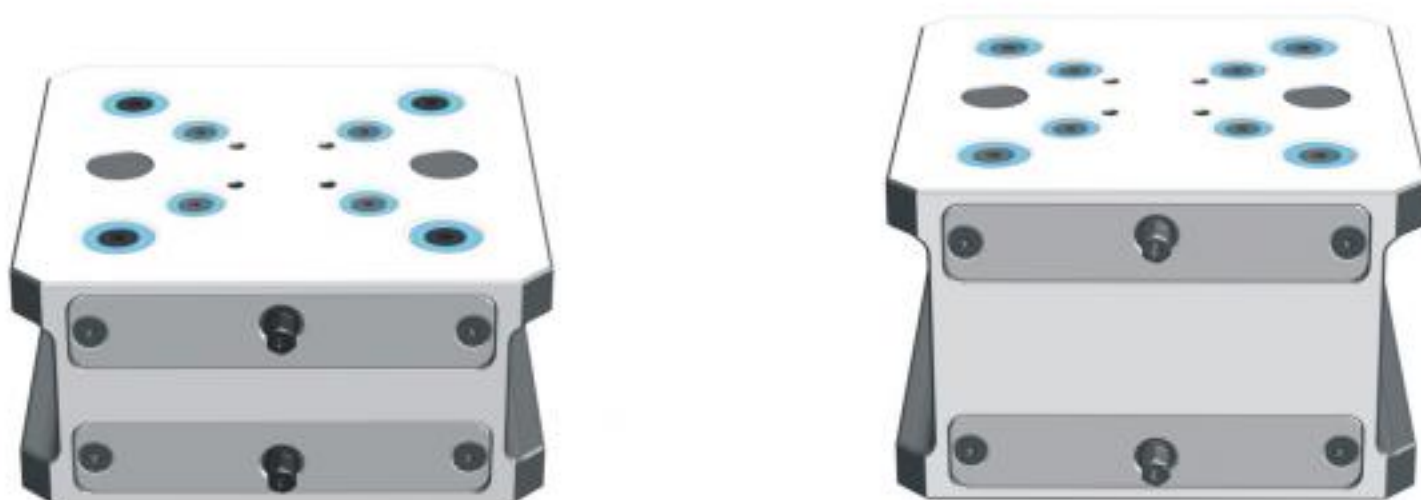

訂購編號 / Order No.		64938-075	64938-100
型號 / Model		<b>EQE075</b>	<b>EQE100</b>
尺寸 / Dimensions	mm	156 x 156 x 75	156 x 156 x 100
零點系統 / Zero-point system	mm	96 / 52	96 / 52
零點螺栓 / Zero-point bolt	mm	Ø20 / 16	Ø20 / 16
適用虎鉗 / Compatible		PQV77-54 / PQV77-75 PQV125-75 / PQV125-125	PQV77-54 / PQV77-75 PQV125-75 / PQV125-125
擰緊力矩 / Max. tightening torque	Nm	45	45
保持力 / Holding force (4 studs)	kN	60	60
定位精度 / Accuracy	mm	0.005	0.005
重量 / Weight	kg	10.5	14.0

## 96 / 52 零點定位校正托盤

## Zero-Point Gauging Pallet

用於快速和精確對準快換板的測量托盤。特別推薦用於轉盤或卡盤，  
Recommended application for rotating axes and chucks.

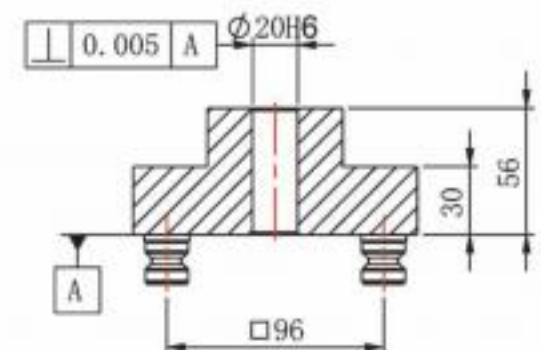
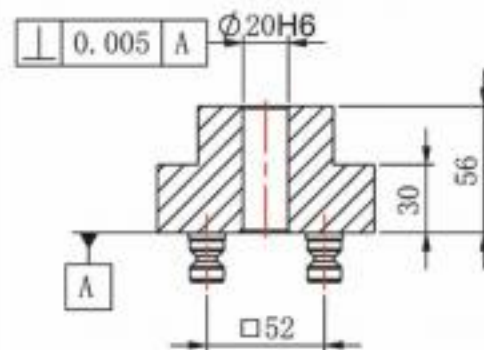
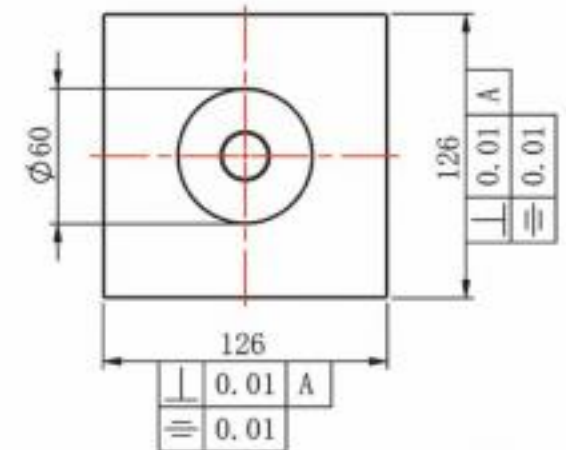
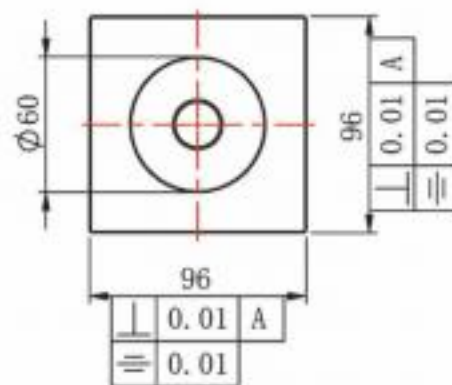
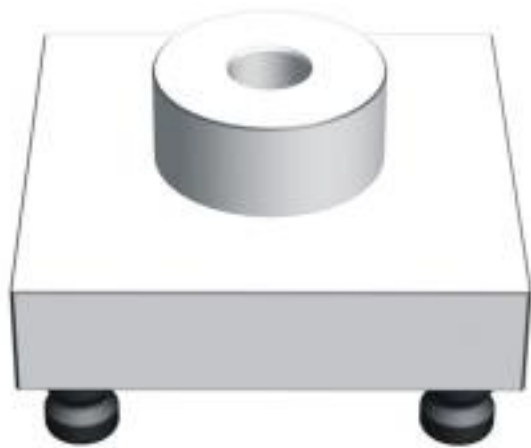

訂購編號 / Order No.	64940-52	64940-96
型號 / Model	EQA52	EQA96
適用於 / Suitable for Zero-point system	□ 52	□ 96
尺寸 / Dimensions	mm 96 x 96 x 56	mm 126 x 126 x 56
測量長度 / Measuring length	mm 每邊95 each side	mm 每邊125 each side
重量 / Weight	kg 2.6	kg 4.2

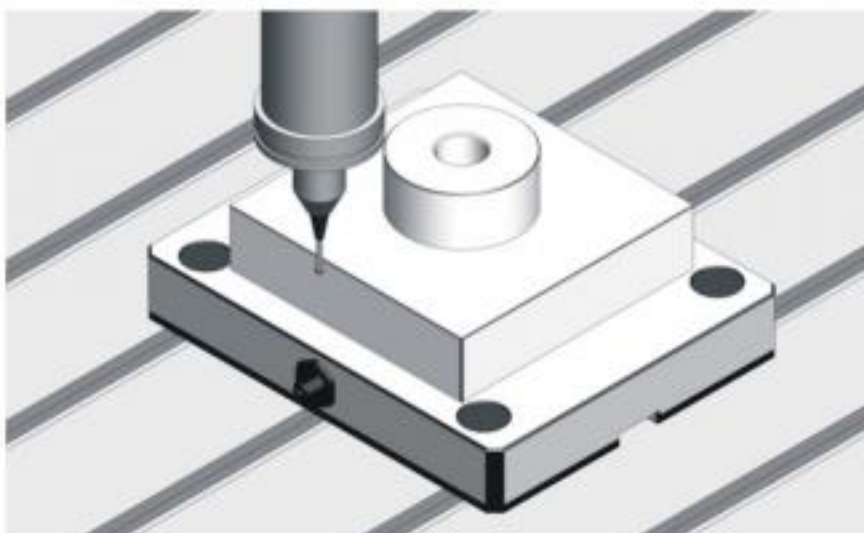

## 它是如何工作的 How it works:

將校正托盤夾緊在快換基座上，探測測量托盤的側邊來完成軸向對準，探測測量托盤內徑來完成同心對準。

The coordinate-ground gauging pallet enables quick and accurate alignment of zero-point plates. For concentric alignment of the zero-point plate, the inner diameter of the measuring body is utilised, while for axial alignment the side surfaces of the measuring body are traversed.



## 96 / 52 快速定位拉緊螺栓

## Zero-Point Clamping Studs

用於將夾具、工件或現有夾具單獨適配到我們的快換零點夾緊系統上。

Studs could be applied to your own jig and fixture to compatible with our zero-point system.



請注意：一個快換板需要4個夾緊螺栓

Note: 4 studs needed for each plate.

訂購編號 / Order No.	64942-16	64942-20
型號 / Model	EQPS16	EQPS20
尺寸 / Dimensions	Ø16	Ø20
適用 / Compatible	□ 52 定位孔	□ 96 定位孔

它是如何工作的：

How it works:

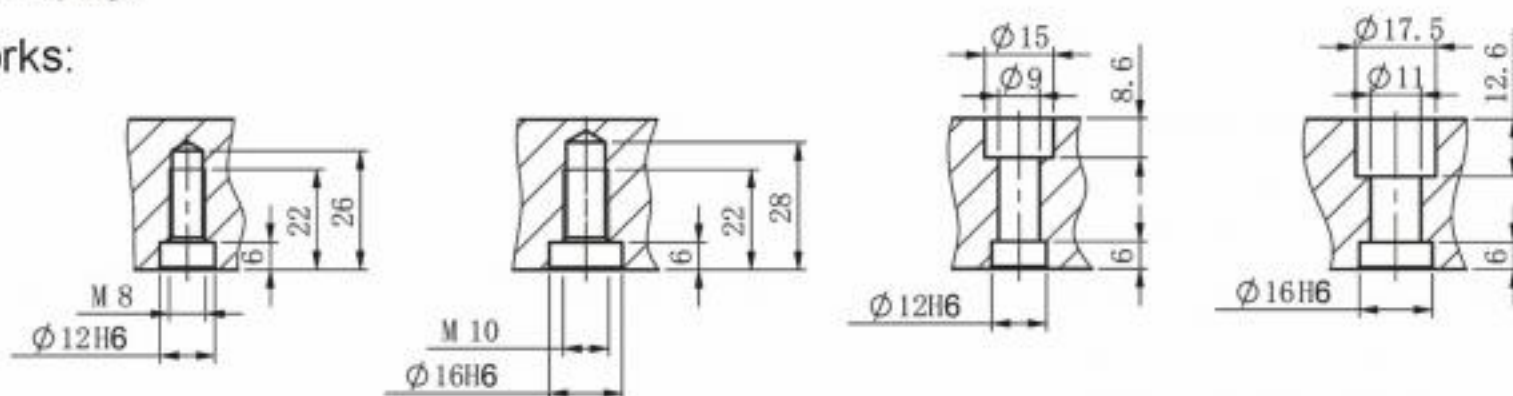

帶螺紋銷  
with threaded pins

帶螺絲  
with screws

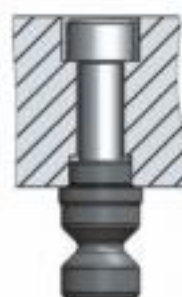

□ 52

□ 96

□ 52

□ 96

# 零點定位系統

## Mechanical Zero-point System

### 定位配件

Alignment Accessories



槽鍵 Slot keys

訂購編號 Order No.	型號 Model	尺寸 Size	重量 N.W.(kg)
64944-18-14	ZA18-14	18x14x28	0.048
64944-20-14	ZA20-14	20x14x28	0.051
64944-20-18	ZA20-18	20x18x28	0.059

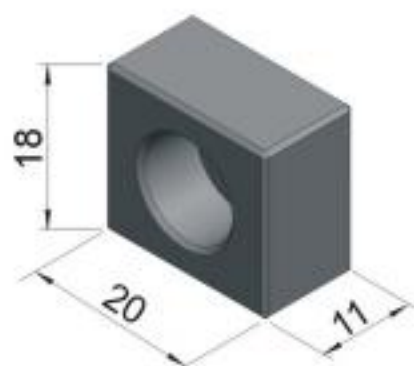

槽鍵 Slot keys

訂購編號 Order No.	型號 Model	尺寸 Size	重量 N.W.(kg)
64946-20-18	ZB20,18	18x20x11	0.025



定位鍵 Centring Studs

訂購編號 Order No.	型號 Model	尺寸 Size	重量 N.W.(kg)
64948-10-10	ZC10-10	∅10x11	0.005
64948-10-12	ZC10-12	∅12x11	0.006
64948-10-14	ZC10-14	∅14x11	0.008
64948-10-16	ZC10-16	∅16x11	0.010
64948-10-18	ZC10-18	∅18x11	0.013
64948-10-20	ZC10-20	∅20x11	0.016
64948-20-20	ZC20-20	∅20x11	0.025



襯套 Bushing

訂購編號 Order No.	型號 Model	尺寸 Size	重量 N.W.(kg)
64950-12-M10	ZD12-M10	∅12x12	0.003
64950-12-M8	ZD12-M8	∅12x12	0.006
64950-16-M10	ZD16-M10	∅16x15	0.011

# 零點定位系統

## Mechanical Zero-point System

### 附屬品

Accessories

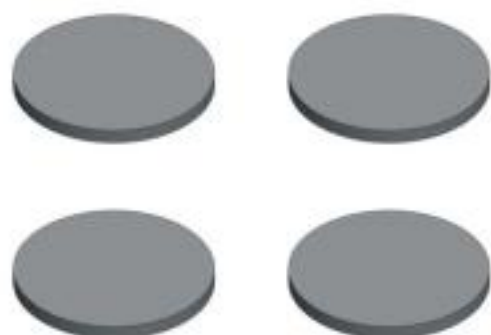

防塵蓋板(塑膠) Dust Plates

Unit:mm

訂購編號 Order No.	型號 Model	內容物 Content
64952-20	ZE20MM	1組4pcs / set of 4 pcs



定位孔栓塞(塑膠附有金屬螺絲) Protective Plugs

Unit:mm

訂購編號 Order No.	型號 Model	內容物 Content
64954-16	ZF16MM	1組4pcs / set of 4 purchase
64954-20	ZF20MM	



可利用磁性筆MSB150將防塵塞取下

The protective plugs can be removed by using the magnetic pen MSB150

磁性筆 Magnetic Pen

Unit:mm

訂購編號 Order No.	型號 Model	L	Holding force
54850-150	MSB150	135-650	1.8kg



\*\*Gin Tech reserves the right to change the specification without prior notice\*\*

**精展精密科技股份有限公司(總公司)  
GIN TECH PRECISION CO., LTD.**

238001台灣新北市樹林區保安街一段341巷7號  
Address: No 7, Lane 341, Sec. 1, Bau An Street, Shu lin Dist.,  
New Taipei City, 238001, Taiwan  
TEL: 886-2-2681-8596 (Rep.)      Email: Sales@ginchan.com.tw  
FAX: 886-2-2681-8516      Web: www.gin-chan.com

**東莞美商精展機械五金有限公司  
東莞市精展機械五金有限公司  
GIN CHAN MACHINERY & HARDWARE CO., LTD.(DONGGUAN)**

廣東省東莞市大朗鎮石廈村金沙崗二路27號  
Address: No 27, Jinshagang 2nd Road, Shixia Village,  
Dalang Town, Dongguan, Guandong, P.R. China  
TEL : 86-769-8318-5858 (Rep.)      Email: Sales@ginchan.com.cn  
FAX: 86-769-8318-5838/8313-5003      Web: www.ginchan.com.cn



YouTube



微信扫一扫