

# 頂針系列

## Extrusion Series



射梢、司筒  
Ejector Pins/Ejector Sleeves



扁梢  
Rectangular ejector Pin



灌嘴  
Sprue Bush



拉杆  
Puller Bolt



拉料梢  
Runner Lock Pins



導柱、導套  
Leader Pins/  
Leader Bushings



停止銷、華司、支撐柱、限位螺絲  
Stop Pins/Washers/Shore/Limiting Screw



無給油導套、滑動板  
Oil-free Guide Bushings/  
Self Lubricating Plate





 <p><b>GBDS</b> A01 SKD61全硬單節射銷GBDS型 THRU HARD HOT WORK STRAIGHT EJECTOR PINS GBDS TYPE M 材質 SKD61 H 硬度 HRC50°~54°</p>	 <p><b>GEPH</b> A07 SKH51精級單節射銷GEPH型 SKH51 PRECISION STRAIGHT EJECTOR PINS GEPH TYPE M 材質 SKH51 H 硬度 HRC58°~62°</p>	 <p><b>GSD</b> A15 小拉杆A型 PULLER BOLT A TYPE M 材質 SCM435 H 硬度 HRC38°~44°</p>
 <p><b>GBES</b> A02 SKD61全硬雙節射銷GBES型 THRU HARD HOT WORK STEPPED EJECTOR PINS GBES TYPE M 材質 SKD61 H 硬度 HRC50°~54°</p>	 <p><b>GENH</b> A08 SKH51精級雙節射銷GENH型 SKH51 PRECISION STEPPED EJECTOR PINS GENH TYPE M 材質 SKH51 H 硬度 HRC58°~62°</p>	 <p><b>GSB</b> A16 小拉杆C型 PULLER BOLT C TYPE M 材質 SCM435 H 硬度 HRC38°~44°</p>
 <p><b>GBFS</b> A02 SKD61全硬方型扁銷GBFS型 THRU HARD HOT WORK RECTANGULAR EJECTOR PINS GBFS TYPE M 材質 SKD61 H 硬度 HRC50°~54°</p>	 <p><b>GBGT</b> A09 FDAC射銷套筒(司筒)GBGT型 FDAC STRAIGHT EJECTOR SLEEVES GBGT TYPE M 材質 FDAC H 內部硬度(Core) HRC38°~42° 表面硬度(Surface) HV900~</p>	 <p><b>GRP/GRPG</b> A17 拉料銷(一般式) RUNNER LOCK PINS M 材質 SKH51 H 硬度 HRC61°~64°</p>
 <p><b>GBDT</b> A03 SKD61氮化處理單節射銷GBDT型 SKD61 NITRIDED STRAIGHT EJECTOR PINS GBDT TYPE M 材質 SKD61 H 內部硬度(Core) HRC40°~45° 表面硬度(Surface) HV900~</p>	 <p><b>GBHT</b> A10 FDAC雙節射銷套筒GBHT型 FDAC STEPPED EJECTOR SLEEVES GBHT TYPE M 材質 FDAC H 內部硬度(Core) HRC38°~42° 表面硬度(Surface) HV900~</p>	 <p><b>GRN/GRNG</b> A17 拉料銷(正規式) RUNNER LOCK PINS M 材質 SKH51 H 硬度 HRC61°~64°</p>
 <p><b>GBET</b> A04 SKD61氮化處理雙節射銷GBET型 SKD61 NITRIDED STEPPED EJECTOR PINS GBET TYPE M 材質 SKD61 H 內部硬度(Core) HRC40°~45° 表面硬度(Surface) HV900~</p>	 <p><b>GSB A</b> A11 灌嘴A型 SPRUE BUSH A TYPE M 材質 S45C / SUJ2 / SKD61 H 硬度 SR部加硬HRC40°以上 HRC58°~62° HRC50°~54°</p>	 <p><b>GAP</b> A18 斜撐銷 ANGULAR PIN M 材質 SUJ2 H 硬度 HRC60°±2° S 表面處理 高週波處理</p>
 <p><b>GBFT</b> A04 SKD61氮化處理方型扁銷GBFT型 SKD61 NITRIDED RECTANGULAR EJECTOR PINS GBFT TYPE M 材質 SKD61 H 內部硬度(Core) HRC40°~45° 表面硬度(Surface) HV900~</p>	 <p><b>GSB B</b> A12 灌嘴B型 SPRUE BUSH B TYPE M 材質 S45C / SUJ2 / SKD61 H 硬度 SR部加硬HRC40°以上 HRC58°~62° HRC50°~54°</p>	 <p><b>GLN</b> A19 精密級導柱(附油溝式) PRECISION LEADER PINS (WITH OIL GROOVE TYPE) M 材質 SUJ2 H 硬度 HRC58°(高週波燒入)</p>
 <p><b>GEPS</b> A05 SKH51單節射銷GEPS型 SKH51 STRAIGHT EJECTOR PINS GEPS TYPE M 材質 SKH51 H 硬度 HRC58°~62°</p>	 <p><b>GSBC</b> A13 灌嘴C型 SPRUE BUSH C TYPE M 材質 S45C H 硬度 SR部加硬HRC40°以上</p>	 <p><b>GBD</b> A21 精密級襯套(凸緣式) PRECISION LEADER BUSHINGS (FLANGE TYPE) M 材質 SUJ2 H 硬度 HRC58°</p>
 <p><b>GCES</b> A06 SKH51雙節射銷GCES型 SKH51 STEPPED EJECTOR PINS GCES TYPE M 材質 SKH51 H 硬度 HRC58°~62°</p>	 <p><b>GLRA</b> A14 定位圈A型 LOCATING RING - A TYPE M 材質 S45C</p>	 <p><b>GBE</b> A22 精密級襯套(直式) PRECISION LEADER BUSHINGS (STRAIGHT TYPE) M 材質 SUJ2 H 硬度 HRC58°</p>
 <p><b>GCFS</b> A06 SKH51方型扁銷GCFS型 SKH51 RECTANGULAR EJECTOR PINS GCFS TYPE M 材質 SKH51 H 硬度 HRC58°~62°</p>	 <p><b>GLRB</b> A14 定位圈B型 LOCATING RING - B TYPE M 材質 S45C</p>	 <p><b>GBF</b> A22 導套(配鋼珠套用) EJECTOR BALL BUSHINGS (BALL TYPE) M 材質 SUJ2 H 硬度 HRC58°</p>



**GSPA** A23  
停止銷  
stop pins



**CYM** B01  
卡位式傳統日期章  
TRADITIONAL DATE STAMP  
M 材質 SUS420  
H 硬度 HRC48°~50°



**TTBP** B09  
可移動水柱塞  
COOLING CIRCUIT PLUGS  
M 材質 黃銅(C3604)



**GSPB** A23  
停止銷  
stop pins



**DTAA** B02  
可分拆式日期章  
SPLIT-TYPE DATE STAMP  
M 材質 SUS420  
H 硬度 HRC48°~50°



**Z942** B10  
止水栓  
COOLING CIRCUIT PLUGS



**GWA/B/C** A23  
汎用型華司・皿頭型華司  
WASHERS  
M 材質 S45C  
H 硬度 HRC46°~50°



**DYY** B02  
日期章內指針鑲件  
INNER POINTER OF DATE STAMP  
M 材質 SUS420  
H 硬度 HRC48°~50°



**GVA** B11  
氣頂  
AIR VALVES  
M 材質 SUS420  
H 硬度 HRC48°~54°



**GSH** A24  
支撐柱  
SHORE



**UYM** B03  
內鑲件可換式日期章  
INSERTED RENEWABLE  
DATE SEAL  
M 材質 SUS420  
H 硬度 HRC48°~50°



**GAJV** B12  
氣頂  
AIR VALVES  
M 材質 SUS420  
H 硬度 HRC48°~54°



**GLS** A24  
限位螺絲  
LIMITING SCREW  
M 材質 S45C  
H 硬度 HRC35°±2°  
S 表面處理 發藍(Fe3O4)



**FD** B04  
三層組合型日期章  
THREE-LAY COMBINED DATE  
STAMP  
歐式西班牙標準  
European Spanish standard  
M 材質 SUS420  
H 硬度 HRC48°~50°



**GVJ** B13  
氣頂  
AIR VALVES  
M 材質 SUS420  
H 硬度 HRC48°~54°



**GPB** A25  
無給油導套(銅合金)  
OIL-FREE GUIDE BUSHINGS  
M 材質: 銅合金  
石墨(黑鉛)



**FDA** B04  
三層組合型日期章  
THREE-LAY COMBINED DATE  
STAMP  
M 材質 SUS420  
H 硬度 HRC48°~50°



**GFA** B13  
氣頂  
AIR VALVES  
M 材質 SUS420  
H 硬度 HRC48°~54°



**GPF** A26  
無給油凸緣導套  
OIL-FREE FLANGE GUIDE  
BUSHINGS  
M 材質: 銅合金  
石墨(黑鉛)



**BT01** B05  
環保日期章  
RECYCLING INSERTS



**GVD** B13  
氣頂  
AIR VALVES  
M 材質 SUS420  
H 硬度 HRC48°~54°



**GPP** A27  
無給油滑動板  
SELF LUBRICATING PLATE  
M 材質: 銅合金  
石墨(黑鉛)



**GH** B06  
冷卻棒(熱管)  
HEAT SINK  
M 材質 銅+冷卻液



**APV** B14  
氣頂  
AIR VALVES  
M 材質 SUS420  
H 硬度 HRC48°~54°



**GPH** A28  
無給油耐磨滑板  
SELF LUBRICATING PLATE  
-EXTRA RESIST-  
M 材質: 銅合金  
石墨(黑鉛)



**GCA/GCB/GCT** B07  
冷卻螺旋水套  
SPIRAL BAFFLE TUBE



**GAS** B15  
排氣栓  
GAS VENT  
M 不銹鋼——射出模具專用  
H 硬度 RV50 孔徑 0.05  
M 銅——中空模具專用  
H 硬度 RV20 孔徑 0.35





# 頂針系列 Extrusion Series

**GBDS**

SKD61全硬單節射梢GBDS型

Thru Hard Hot Work Straight Ejector Pins Gbds Type

塑膠模用標準零配件

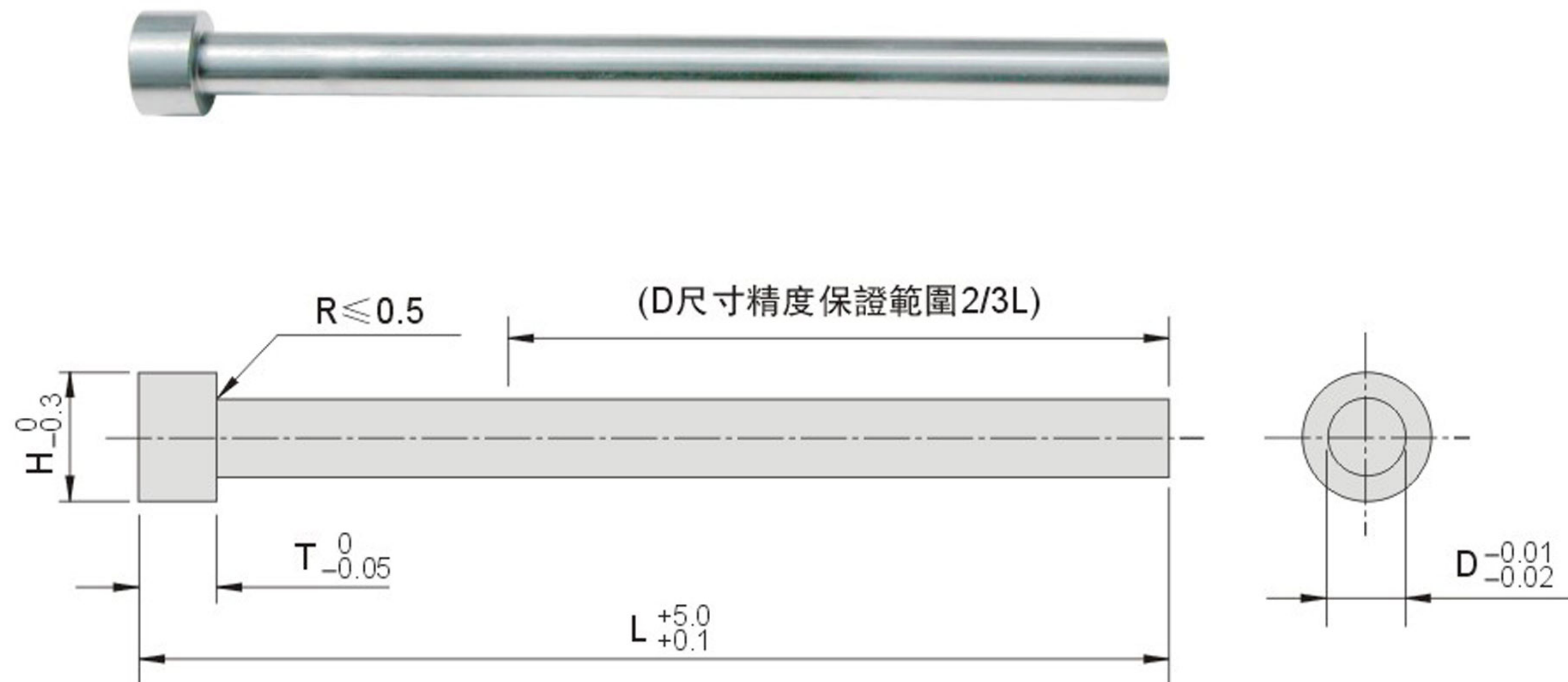

**M** 材質 SKD61  
**H** 硬度 HRC50°~54°

公制: mm

Type	頭厚 T 0 -0.05	頭徑 H 0 -0.3	外徑 D -0.01 -0.02	長度 L <sup>+5.0</sup> <sub>+0.1</sub>							
				100	150	200	250	300	350	400	
GBDS	4	6	1.0	○	○	○	○	○	○	○	
			1.2	○	○	○	○	○	○	○	
			1.5	○	○	○	○	○	○	○	
			2.0	○	○	○	○	○	○	○	
			2.5	○	○	○	○	○	○	○	
			3.0	○	○	○	○	○	○	○	
	6	7	3.5	○	○	○	○	○	○	○	
			8	4.0	○	○	○	○	○	○	○
				4.5	○	○	○	○	○	○	○
			9	5.0	○	○	○	○	○	○	○
				10	5.5	○	○	○	○	○	○
			11		6.0	○	○	○	○	○	○
	11	6.5		○	○	○	○	○	○	○	
		11	7.0	○	○	○	○	○	○	○	
	8		8	13	○	○	○	○	○	○	○
		14		○	○	○	○	○	○	○	
		15		○	○	○	○	○	○	○	
16		○		○	○	○	○	○	○		
17		○		○	○	○	○	○	○		

Order: GBDS - D - L - H - T - Q'TY

※超出以上尺寸或公差價格另計

※D部在12-16之間，D部公差為-0.01至-0.03，長度大於或等於900時，D部公差為-0.01至-0.04



# GBES

## SKD61全硬雙節射梢GBES型 Thru Hard Hot Work Stepped Ejector Pins Gbes Type

塑膠模用標準零配件



**M** 材質 SKD61  
**H** 硬度 HRC50°~54°

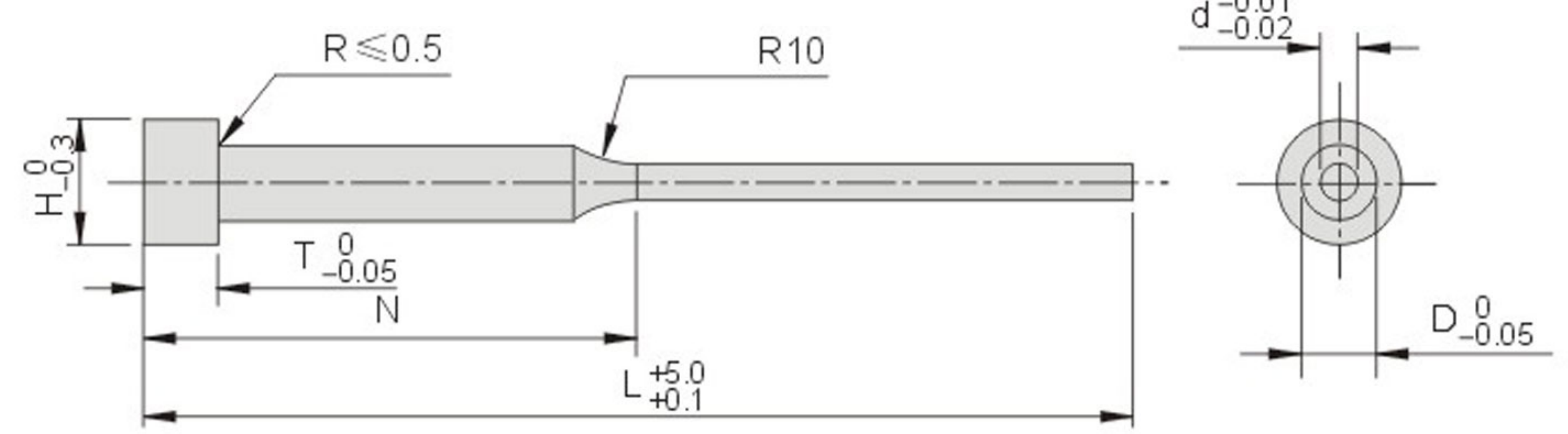

公制: mm

Type	頭厚 T 0 -0.05	頭徑 H 0 -0.3	大徑 D 0 -0.05	小徑 d -0.01 -0.02	長度 L <sup>+5.0</sup> / <sub>+0.1</sub>					
					100		150		200	
					N=40	N=50	N=70	N=70	N=100	
GBES	4	6	2.0	0.8	○	○	○	○	○	
				1.0	○	○	○	○	○	
				1.2	○	○	○	○	○	
				1.5	○	○	○	○	○	
			2.5	0.8	○	○	○	○	○	
				1.0	○	○	○	○	○	
				1.2	○	○	○	○	○	
				1.5	○	○	○	○	○	
			3.0	1.0	○	○	○	○	○	
				1.2	○	○	○	○	○	
				1.5	○	○	○	○	○	
				2.0	○	○	○	○	○	

Order: GBES - D - d - N - L - H - T - Q'TY

※超出以上尺寸或公差價格另計

# GBFS

## SKD61全硬方型扁梢GBFS型 Thru Hard Hot Work Rectangular Ejector Pins Gbfs Type



**M** 材質 SKD61  
**H** 硬度 HRC50°~54°

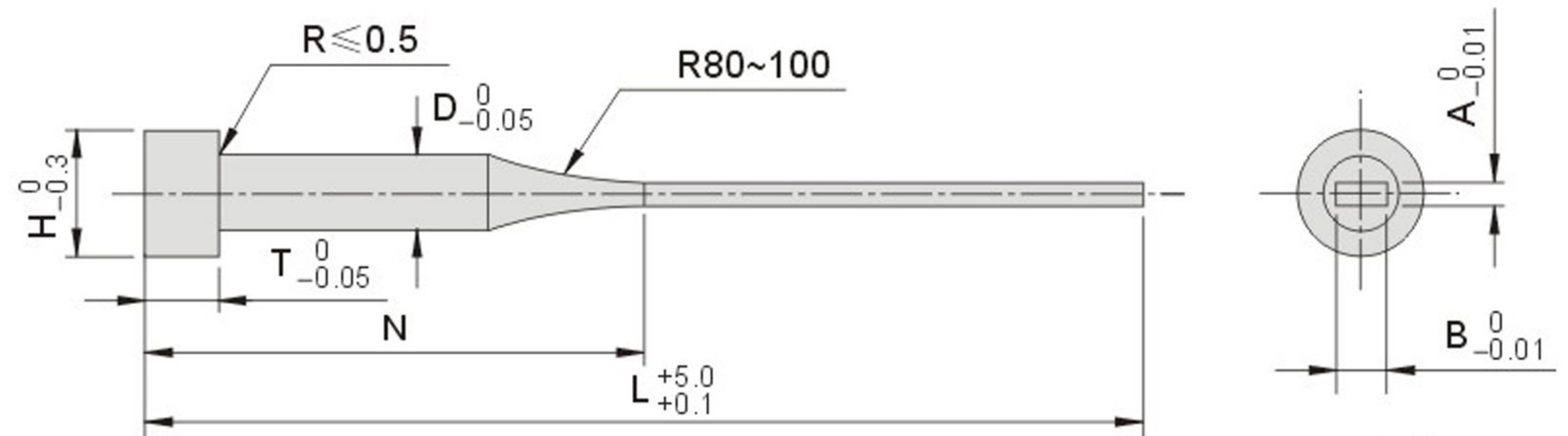

公制: mm

Type	頭厚 T 0 -0.05	頭徑 H 0 -0.3	外徑 D 0 -0.05	長度 L <sup>+5.0</sup> / <sub>+0.1</sub>									
				100	150	200	250	300	350	400	450	500	
GBFS	4	6	2.0	○	○	○							
			2.5	○	○	○							
			3.0	○	○	○	○						
		7	3.5	○	○	○	○						
			8	4.0	○	○	○	○	○				
				4.5	○	○	○	○	○				
	6	9	5.0	○	○	○	○	○					
			10	○	○	○	○	○					
		11	6.0	○	○	○	○	○					
			6.5	○	○	○	○	○	○				
	8	13	7.0	○	○	○	○	○	○	○	○	○	
			7.5	○	○	○	○	○	○	○	○	○	
		14	8.0	○	○	○	○	○	○	○	○	○	
			8.5	○	○	○	○	○	○	○	○	○	
	15	9.0	○	○	○	○	○	○	○	○	○		
		9.5	○	○	○	○	○	○	○	○	○		
17	10.0	○	○	○	○	○	○	○	○	○			
	10.5	○	○	○	○	○	○	○	○	○			

Order: GBFS - D - A - B - N - L - H - T - Q'TY

※超出以上尺寸或公差價格另計  
※N≥30 L-N≥30 A≥0.5 B≥0.8



# 頂針系列 Extrusion Series

**GBDT**

SKD61氮化處理單節射梢GBDT型

SKD61 Nitrided Straight Ejector Pins Gbdt Type

塑膠模用標準零配件

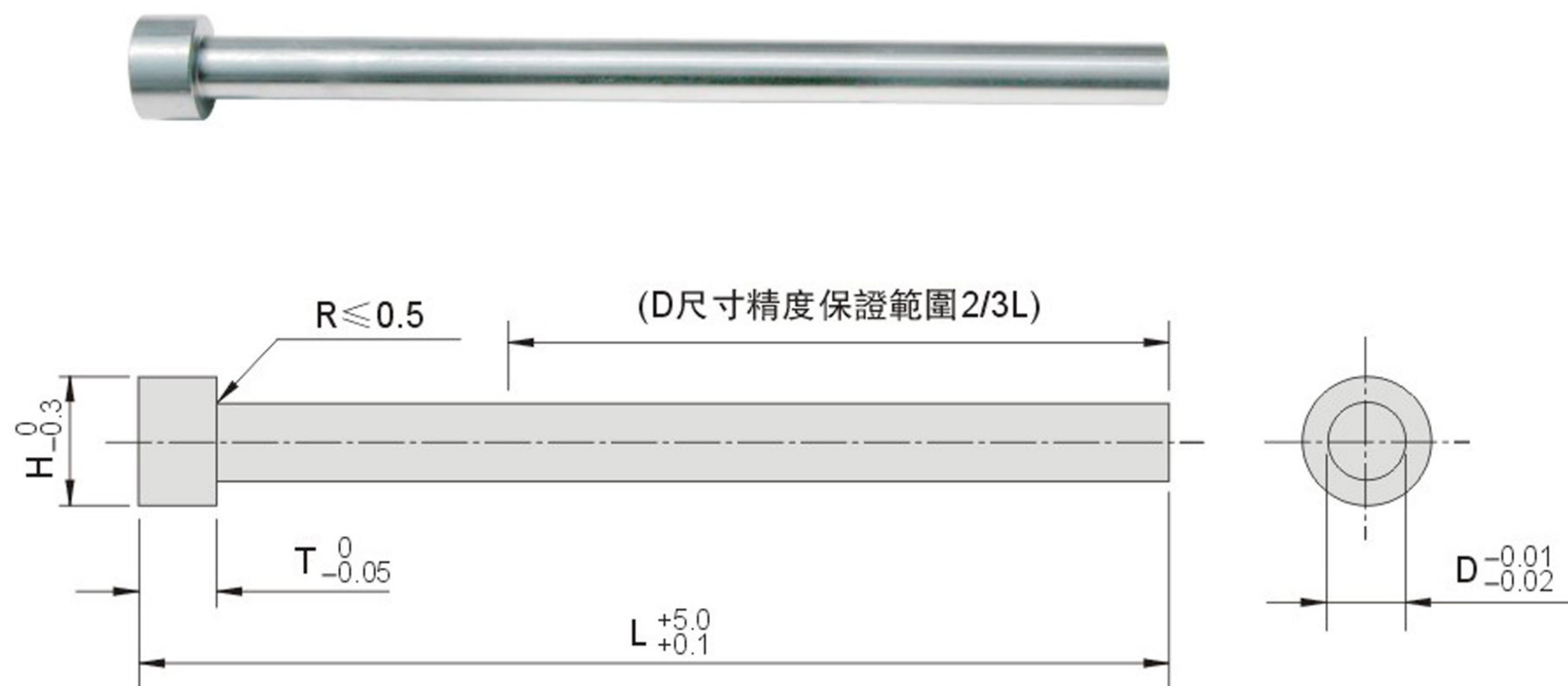

**M** 材質 SKD61  
**H** 內部硬度(Core) HRC40°~45°  
 表面硬度(Surface) HV900~

公制: mm

Type	頭厚 T 0 -0.05	頭徑 H 0 -0.3	外徑 D -0.01 -0.02	長度 L <sup>+5.0</sup> / <sub>+0.1</sub>														
				100	150	200	250	300	350	400	450	500	550	600	650	700	750	800
GBDT	4	6	1.0	○	○	○	○	○	○	○								
			1.2	○	○	○	○	○	○	○	○							
			1.5	○	○	○	○	○	○	○	○	○						
			2.0	○	○	○	○	○	○	○	○	○	○	○	○	○	○	○
			2.5	○	○	○	○	○	○	○	○	○	○	○	○	○	○	○
			3.0	○	○	○	○	○	○	○	○	○	○	○	○	○	○	○
	7	3.5	○	○	○	○	○	○	○	○	○	○	○	○	○	○	○	
	6	8	4.0	○	○	○	○	○	○	○	○	○	○	○	○	○	○	○
		9	4.5	○	○	○	○	○	○	○	○	○	○	○	○	○	○	○
			5.0	○	○	○	○	○	○	○	○	○	○	○	○	○	○	○
		10	5.5	○	○	○	○	○	○	○	○	○	○	○	○	○	○	○
			6.0	○	○	○	○	○	○	○	○	○	○	○	○	○	○	○
		11	6.5	○	○	○	○	○	○	○	○	○	○	○	○	○	○	○
	7.0		○	○	○	○	○	○	○	○	○	○	○	○	○	○	○	
	8	13	8.0	○	○	○	○	○	○	○	○	○	○	○	○	○	○	○
		14	9.0	○	○	○	○	○	○	○	○	○	○	○	○	○	○	○
		15	10.0	○	○	○	○	○	○	○	○	○	○	○	○	○	○	○
17		12.0	○	○	○	○	○	○	○	○	○	○	○	○	○	○	○	

Order: **GBDT** - **D** - **L** - **H** - **T** - Q'TY

※超出以上尺寸或公差價格另計

※D部在12-16之間，D部公差為-0.01至-0.03，長度大於或等於900時，D部公差為-0.01至-0.04



# GBET

## SKD61氮化處理雙節射梢GBET型 SKD61 Nitrided Stepped Ejector Pins Gbet Type

塑膠模用標準零配件

☑ 材質 SKD61

☑ 內部硬度(Core) HRC40°~45°  
表面硬度(Surface) HV900~

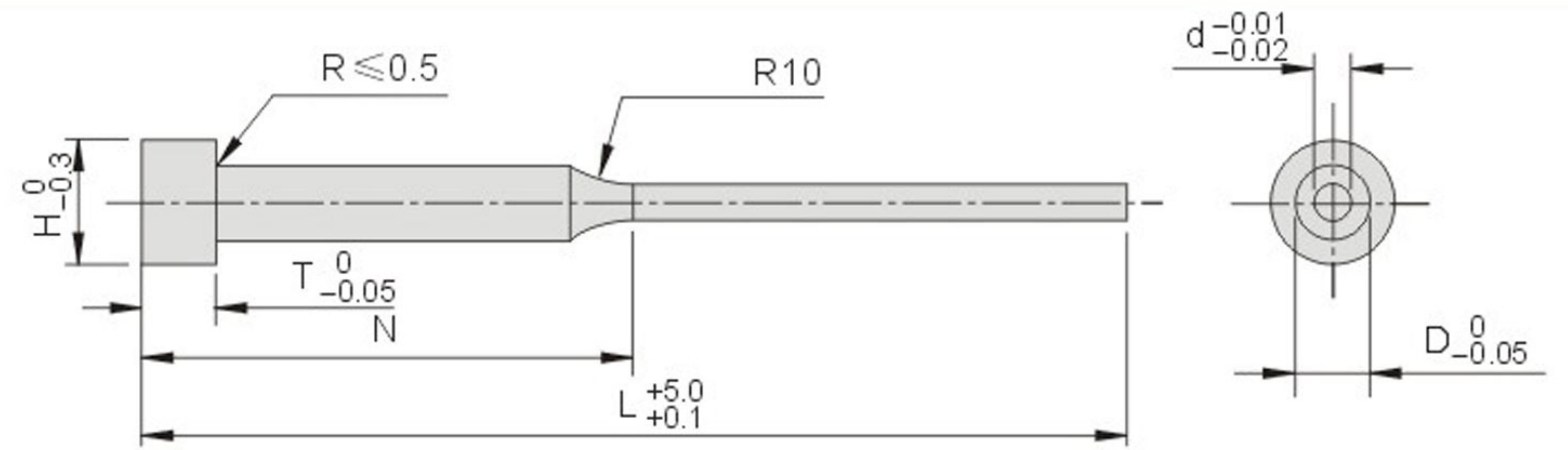

公制: mm

Type	頭厚 T 0 -0.05	頭徑 H 0 -0.3	大徑 D 0 -0.05	小徑 d -0.01 -0.02	長度 L <sup>+5.0</sup> <sub>+0.1</sub>					
					100		150		200	
					N=40	N=50	N=70	N=70	N=100	
GBET	4	6	2.0	0.8	○	○	○	○	○	
				1.0	○	○	○	○	○	
				1.2	○	○	○	○	○	
				1.5	○	○	○	○	○	
				2.5	0.8	○	○	○	○	○
					1.0	○	○	○	○	○
			1.2		○	○	○	○	○	
			1.5		○	○	○	○	○	
			3.0	1.0	○	○	○	○	○	
				1.2	○	○	○	○	○	
				1.5	○	○	○	○	○	
				2.0	○	○	○	○	○	

Order: GBET - D - d - N - L - H - T - Q'TY

※超出以上尺寸或公差價格另計

# GBFT

## SKD61氮化處理方型扁梢GBFT型 SKD61 Nitrided Rectangular Ejector Pins Gbft Type

GBFT



☑ 材質 SKD61

☑ 內部硬度(Core) HRC40°~45°  
表面硬度(Surface) HV900~

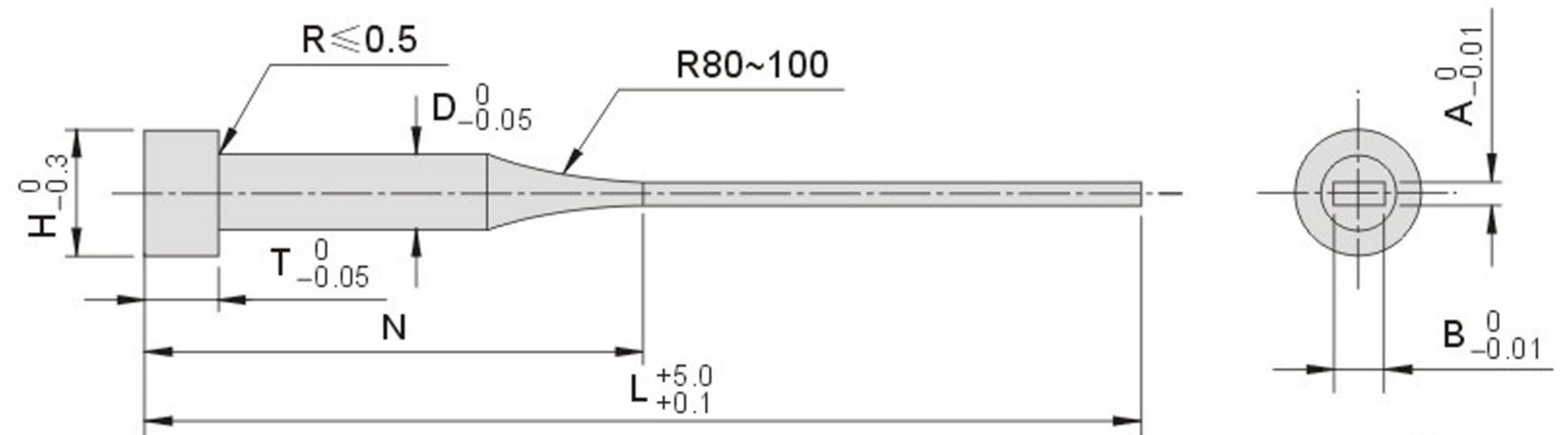

公制: mm

Type	頭厚 T 0 -0.05	頭徑 H 0 -0.3	外徑 D 0 -0.05	長度 L <sup>+5.0</sup> <sub>+0.1</sub>									
				100	150	200	250	300	350	400	450	500	
GBFT	4	6	2.0	○	○	○							
			2.5	○	○	○							
			3.0	○	○	○	○						
		7	3.5	○	○	○	○						
			8	4.0	○	○	○	○	○				
				4.5	○	○	○	○	○	○			
	6	10	5.0	○	○	○	○	○	○				
			5.5	○	○	○	○	○	○	○			
		11	6.0	○	○	○	○	○	○	○	○		
			6.5	○	○	○	○	○	○	○	○	○	
	8	13	7.0	○	○	○	○	○	○	○	○	○	
			7.5	○	○	○	○	○	○	○	○	○	
		15	8.0	○	○	○	○	○	○	○	○	○	
			8.5	○	○	○	○	○	○	○	○	○	
	17	9.0	○	○	○	○	○	○	○	○	○		
		9.5	○	○	○	○	○	○	○	○	○		

Order: GBFT - D - A - B - N - L - H - T - Q'TY

※超出以上尺寸或公差價格另計  
※N≥30 L-N≥30 A≥0.5 B≥0.8



# 頂針系列 Extrusion Series

**GEPS**

SKH51單節射梢GEPS型 SKH51 Straight Ejector Pins Geps Type

塑膠模用標準零配件

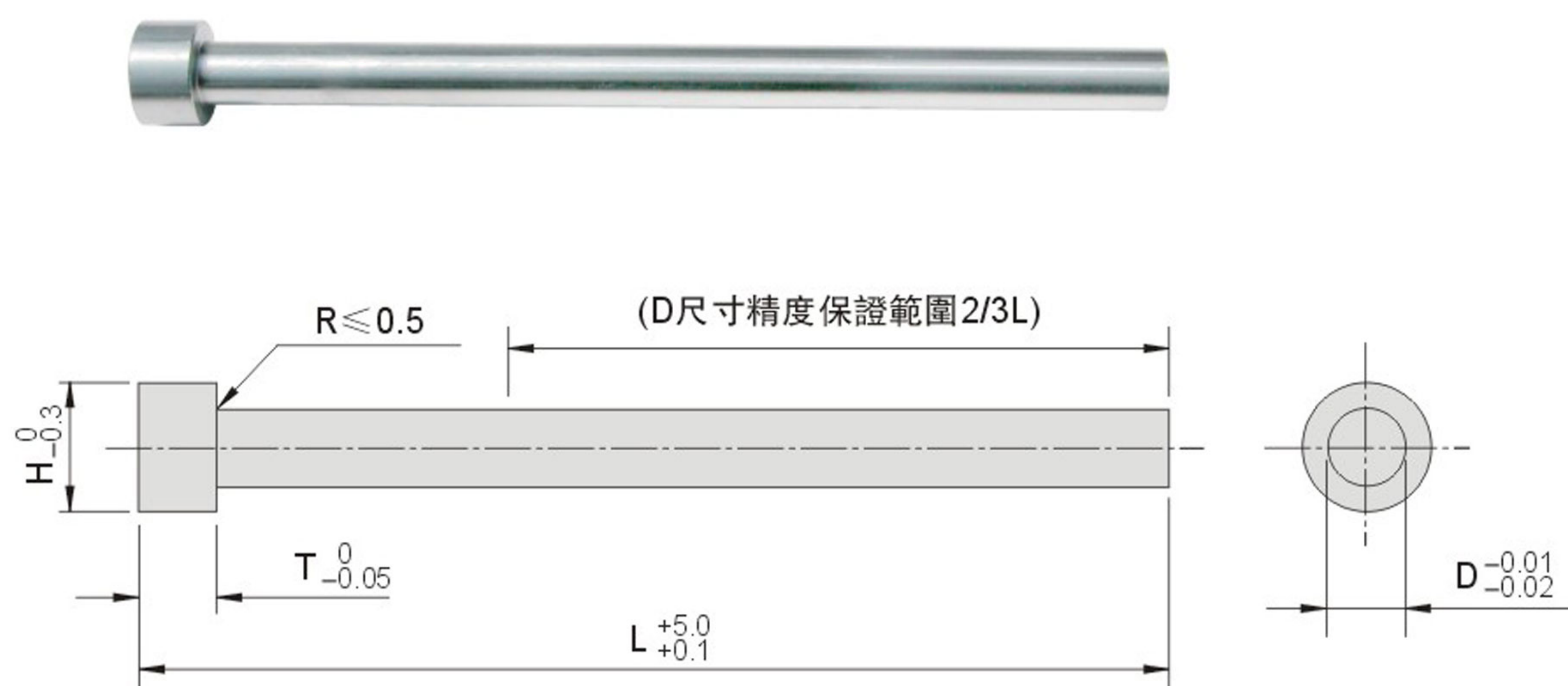

M 材質 SKH51  
H 硬度 HRC58°~62°

公制: mm

Type	頭厚 T 0 -0.02	頭徑 H 0 -0.3	外徑 D -0.01 -0.02	長度 L <sup>+5.0</sup> <sub>+0.1</sub>						
				100	150	200	250	300		
GEPS	4	3	0.8	○	○					
			0.9	○	○					
			1.0	○	○					
			1.1	○	○					
			1.2	○	○					
			1.3	○	○					
			1.4	○	○					
			1.5	○	○	○				
			1.6	○	○					
	4	4	1.7	○	○					
			1.8	○	○					
			1.9	○	○					
			2.0	○	○	○	○			
	4 • 6	5	2.5	○	○	○	○			
			6	3.0	○	○	○	○	○	
		7	3.5	○	○	○	○	○	○	
			4.0	○	○	○	○	○	○	
			9	4.5	○	○	○	○	○	○
				5.0		○	○	○	○	○
	4 • 8	10	5.5	○	○	○	○	○	○	
			6.0		○	○	○	○	○	
11		6.5		○	○	○	○	○		
		7.0		○	○	○	○	○		
13		8.0		○	○	○	○	○		
		14	9.0		○	○	○			
	15	10.0		○	○	○	○			
	16	11.0		○	○	○				
17	12.0		○	○	○	○	○			

Order: GEPS - D - L - H - T - Q'TY

※超出以上尺寸或公差價格另計



# GCES

## SKH51雙節射梢GCES型 SKH51 Stepped Ejector Pins Gces Type

塑膠模用標準零配件



M 材質 SKH51  
H 硬度 HRC58°~62°

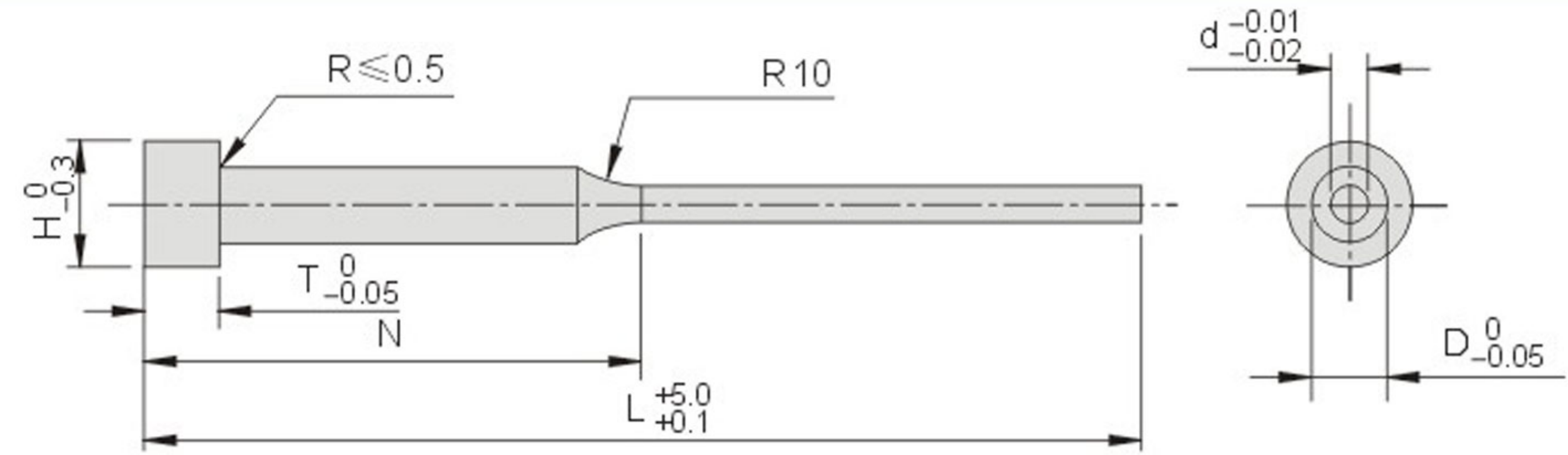

公制: mm

Type	頭厚 T 0 -0.02	頭徑 H 0 -0.3	大徑 D 0 -0.05	小徑 d -0.01 -0.02	長度 L <sup>+5.0</sup> / <sub>+0.1</sub>						
					100		150		200		
					N=40	N=50	N=70	N=70	N=100		
GCES	4	4	2.0	0.8	○	○	○				
				1.0	○	○	○				
				1.2	○	○	○				
				1.5	○	○	○				
				5	2.5	0.8	○	○	○		
						1.0	○	○	○	○	○
		1.2	○			○	○	○	○		
		1.5	○			○	○	○	○		
		6	3.0	1.0	○	○	○	○	○		
				1.2	○	○	○	○	○		
				1.5	○	○	○	○	○		
				2.0	○	○	○	○	○		

Order: GCES - D - d - N - L - H - T - Q'TY

※超出以上尺寸或公差價格另計

# GCFS

## SKH51方型扁梢GCFS型 SKH51 Rectangular Ejector Pins Gcfs Type



M 材質 SKH51  
H 硬度 HRC58°~62°

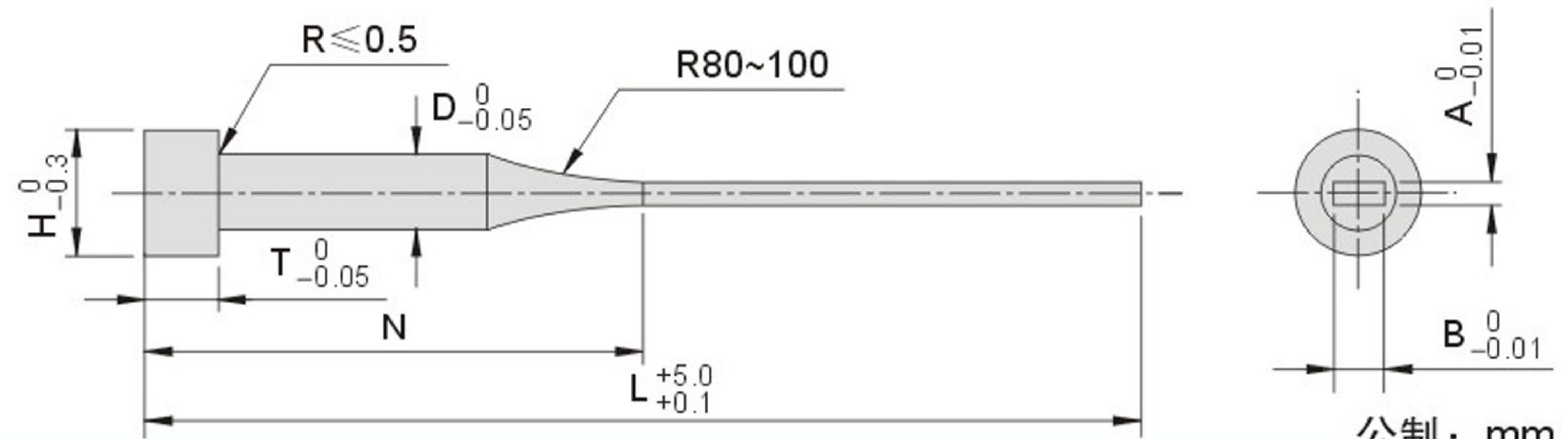

公制: mm

Type	頭厚 T 0 -0.02	頭徑 H 0 -0.3	外徑 D 0 -0.05	長度 L <sup>+5.0</sup> / <sub>+0.1</sub>					
				100	150	200	250	300	350
GCFS	4	3	1.5	○	○	○			
			2.0	○	○	○			
			2.5	○	○	○			
			3.0	○	○	○	○	○	
			3.5	○	○	○	○	○	
		7	4.0	○	○	○	○	○	
			4.5	○	○	○	○	○	
		6	9	5.0	○	○	○	○	○
				5.5	○	○	○	○	○
				6.0	○	○	○	○	○
	4 • 8	11	6.5	○	○	○	○	○	
			7.0	○	○	○	○	○	
		13	8.0	○	○	○	○	○	
			9.0	○	○	○	○	○	
		15	10.0	○	○	○	○	○	
			12.0	○	○	○	○	○	

Order: GCFS - D - A - B - N - L - H - T - Q'TY

※超出以上尺寸或公差價格另計



# 頂針系列 Extrusion Series

## GEPH SKH51精級單節射梢GEPH型

SKH51 Precision Straight Ejector Pins Geph Type

塑膠模用標準零配件

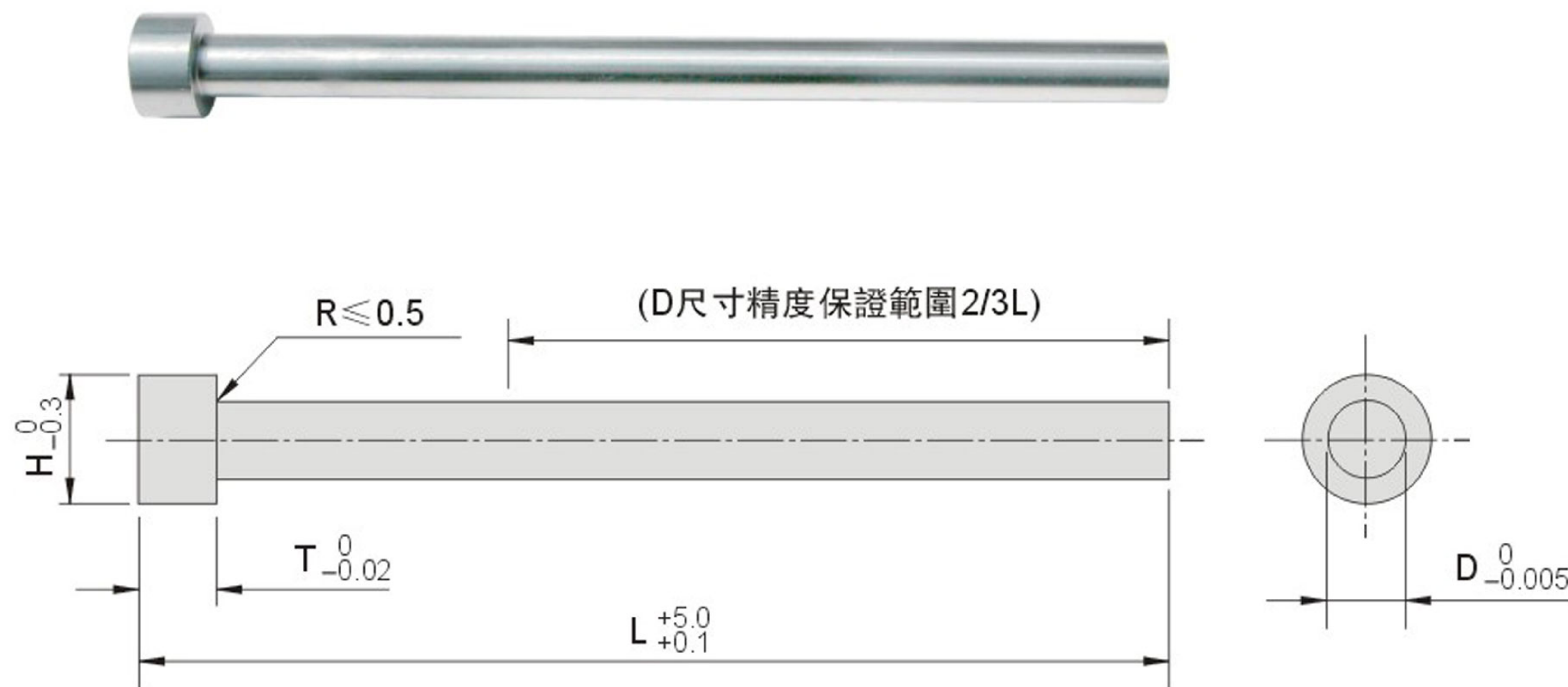

**M** 材質 SKH51  
**H** 硬度 HRC58°~62°

公制: mm

Type	頭厚 T 0 -0.02	頭徑 H 0 -0.3	外徑 D 0 -0.005	長度 L <sup>+5.0</sup> / <sub>+0.1</sub>				
				100	150	200	250	300
GEPH	4	3	0.8	○	○			
			0.9	○	○			
			1.0	○	○			
			1.1	○	○			
			1.2	○	○			
			1.3	○	○			
			1.4	○	○			
			1.5	○	○	○		
			1.6	○	○			
	4	4	1.7	○	○			
			1.8	○	○			
			1.9	○	○			
			2.0	○	○	○	○	
	4 • 6	5	2.5	○	○	○	○	
			3.0	○	○	○	○	○
		7	3.5	○	○	○	○	○
			4.0	○	○	○	○	○
		9	4.5	○	○	○	○	○
			5.0		○	○	○	○
		10	5.5	○	○	○	○	○
			6.0		○	○	○	○
4 • 8		11	6.5		○	○	○	○
			7.0		○	○	○	○
	13	8.0		○	○	○	○	
		9.0		○	○	○		
	14	9.0		○	○	○		
		10.0		○	○	○	○	
	15	10.0		○	○	○	○	
16	11.0		○	○	○			
17	12.0		○	○	○	○		

Order: GEPH - D - L - H - T - Q'TY

※超出以上尺寸或公差價格另計



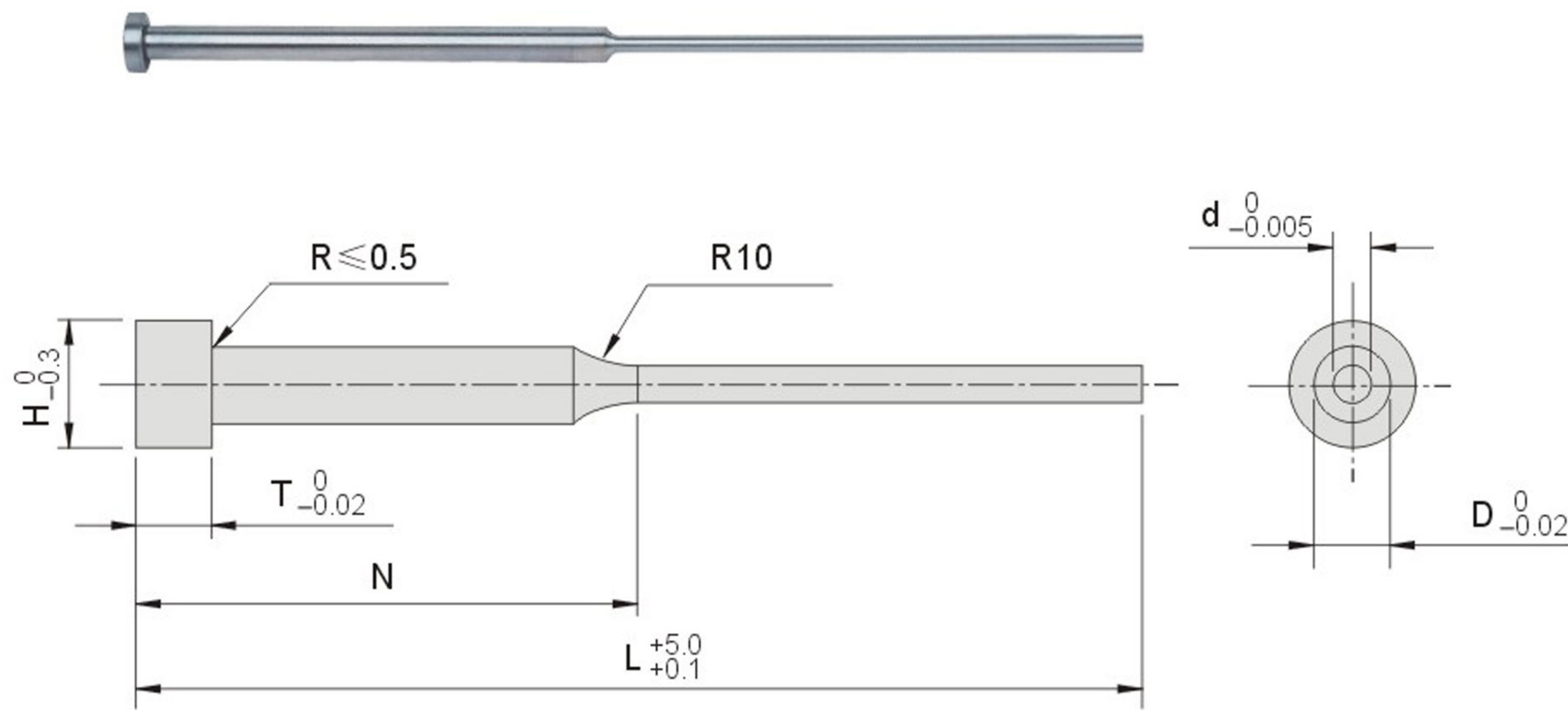

M 材質 SKH51  
H 硬度 HRC58°~62°

公制: mm

Type	頭厚 T 0 -0.02	頭徑 H 0 -0.3	大徑 D 0 -0.02	小徑 d 0 -0.005	長度 L <sup>+5.0</sup> <sub>+0.1</sub>				
					100	150		200	
					N=40	N=50	N=70	N=70	N=100
GENH	4	4	2.0	0.8	○	○	○		
				1.0	○	○	○		
				1.2	○	○	○		
				1.5	○	○	○		
		5	2.5	0.8	○	○	○		
				1.0	○	○	○	○	○
				1.2	○	○	○	○	○
				1.5	○	○	○	○	○
		6	3.0	1.0	○	○	○	○	○
				1.2	○	○	○	○	○
				1.5	○	○	○	○	○
				2.0	○	○	○	○	○

📞 Order: GENH - D - d - N - L - H - T - Q'TY

※超出以上尺寸或公差價格另計



# 頂針系列 Extrusion Series

**GBGT**

FDAC射梢套筒(司筒) GBGT型 FDAC Straight Ejector Sleeves Gbgt Type

塑膠模用標準零配件

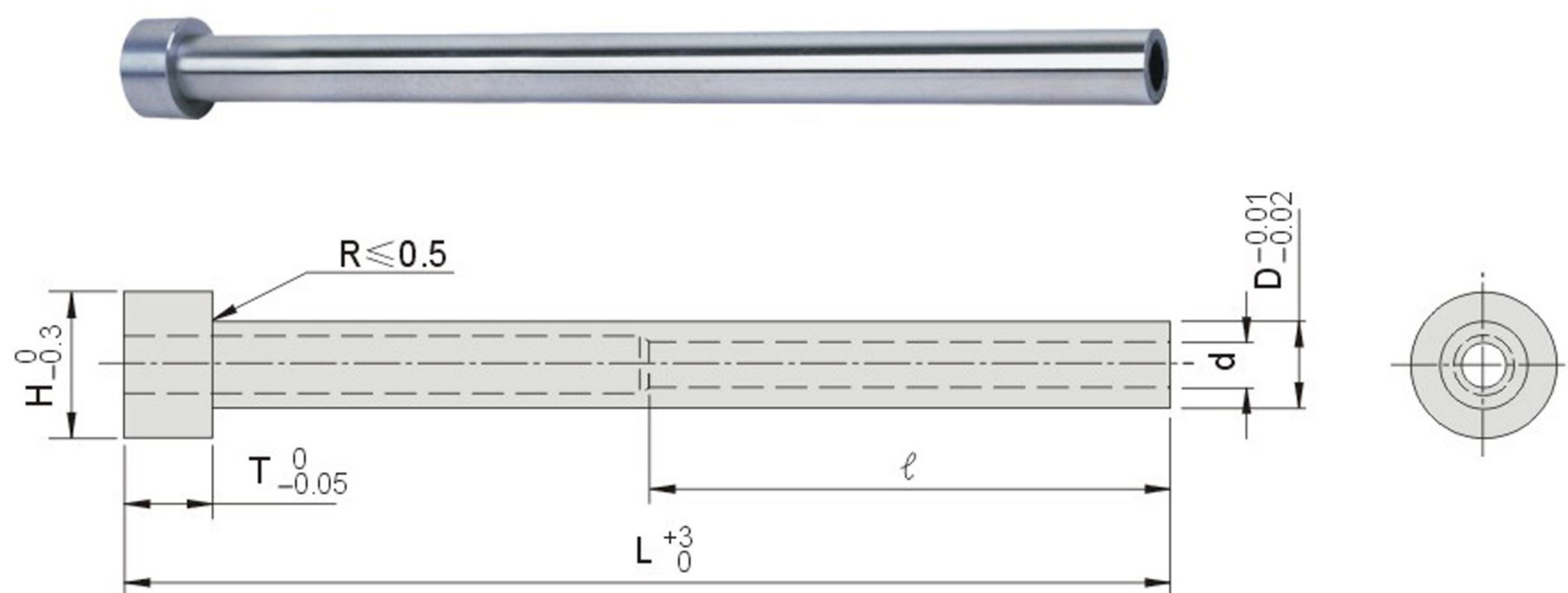

**M** 材質 FDAC  
**H** 內部硬度(Core) HRC38°~42°  
 表面硬度(Surface) HV900~

公制: mm

Type	頭厚 T 0 -0.05	頭徑 H 0 -0.3	外徑 D -0.01 -0.02	內孔 d H7	長度 L <sup>+3</sup> <sub>0</sub>																
					100	150	200	250	300	350	400	450	500	550	600	650	700	750	800		
GBGT	6	8	4	2	○	○	○	○	○												
				2.5	○	○	○	○	○												
		9	4.5	2/2.5	○	○	○	○	○	○											
				3	○	○	○	○	○	○											
		5	2/2.5/3	○	○	○	○	○	○	○	○										
			3.5	○	○	○	○	○	○	○											
		10	5.5	2/2.5	○	○	○	○	○	○	○	○	○	○	○						
				3/3.5	○	○	○	○	○	○	○	○	○	○							
			6	4	○	○	○	○	○	○	○										
				2/2.5	○	○	○	○	○	○	○	○	○	○	○	○					
		11	6.5	3/3.5	○	○	○	○	○	○	○	○	○	○	○	○					
				4	○	○	○	○	○	○	○	○	○	○	○						
	7		2/2.5/3/3.5	○	○	○	○	○	○	○	○	○	○	○	○	○					
			4/4.5/5	○	○	○	○	○	○	○	○	○	○	○	○	○					
	5.5		5	○	○	○	○	○	○	○	○	○	○	○	○	○					
			5.5	○	○	○	○	○	○	○	○	○	○	○	○	○					
	8	13	8	3/3.5/4	○	○	○	○	○	○	○	○	○	○	○	○	○	○	○	○	○
				4.5/5/5.5	○	○	○	○	○	○	○	○	○	○	○	○	○	○	○	○	○
				6	○	○	○	○	○	○	○	○	○	○	○	○	○	○	○	○	○
		14	9	3.5/4/4.5	○	○	○	○	○	○	○	○	○	○	○	○	○	○	○	○	○
				5/5.5/6	○	○	○	○	○	○	○	○	○	○	○	○	○	○	○	○	○
				6.5/7	○	○	○	○	○	○	○	○	○	○	○	○	○	○	○	○	○
		15	10	3.5/4/4.5	○	○	○	○	○	○	○	○	○	○	○	○	○	○	○	○	○
				5/5.5/6	○	○	○	○	○	○	○	○	○	○	○	○	○	○	○	○	○
6.5/7				○	○	○	○	○	○	○	○	○	○	○	○	○	○	○	○	○	
16		11	3.5/4/4.5	○	○	○	○	○	○	○	○	○	○	○	○	○	○	○	○	○	
			5/5.5/6	○	○	○	○	○	○	○	○	○	○	○	○	○	○	○	○	○	
			6.5/7/7.5	○	○	○	○	○	○	○	○	○	○	○	○	○	○	○	○	○	
17	12	8	○	○	○	○	○	○	○	○	○	○	○	○	○	○	○	○	○		
		3.5/4/4.5	○	○	○	○	○	○	○	○	○	○	○	○	○	○	○	○	○		
		5/5.5/6	○	○	○	○	○	○	○	○	○	○	○	○	○	○	○	○	○		
6.5/7/7.5	8	○	○	○	○	○	○	○	○	○	○	○	○	○	○	○	○	○			
	8	○	○	○	○	○	○	○	○	○	○	○	○	○	○	○	○	○			

Order: GBGT - D - d - ℓ - L - - -

※D=12時, 公差D:-0.01/-0.03  
 d=2~3時 公差d:+0.01/0, d=3.5~6時 公差d:+0.012/0, d=7~10時 公差d:+0.015/0, d=11~12時 公差d:+0.018/0  
 ※超出以上尺寸或公差價格另計



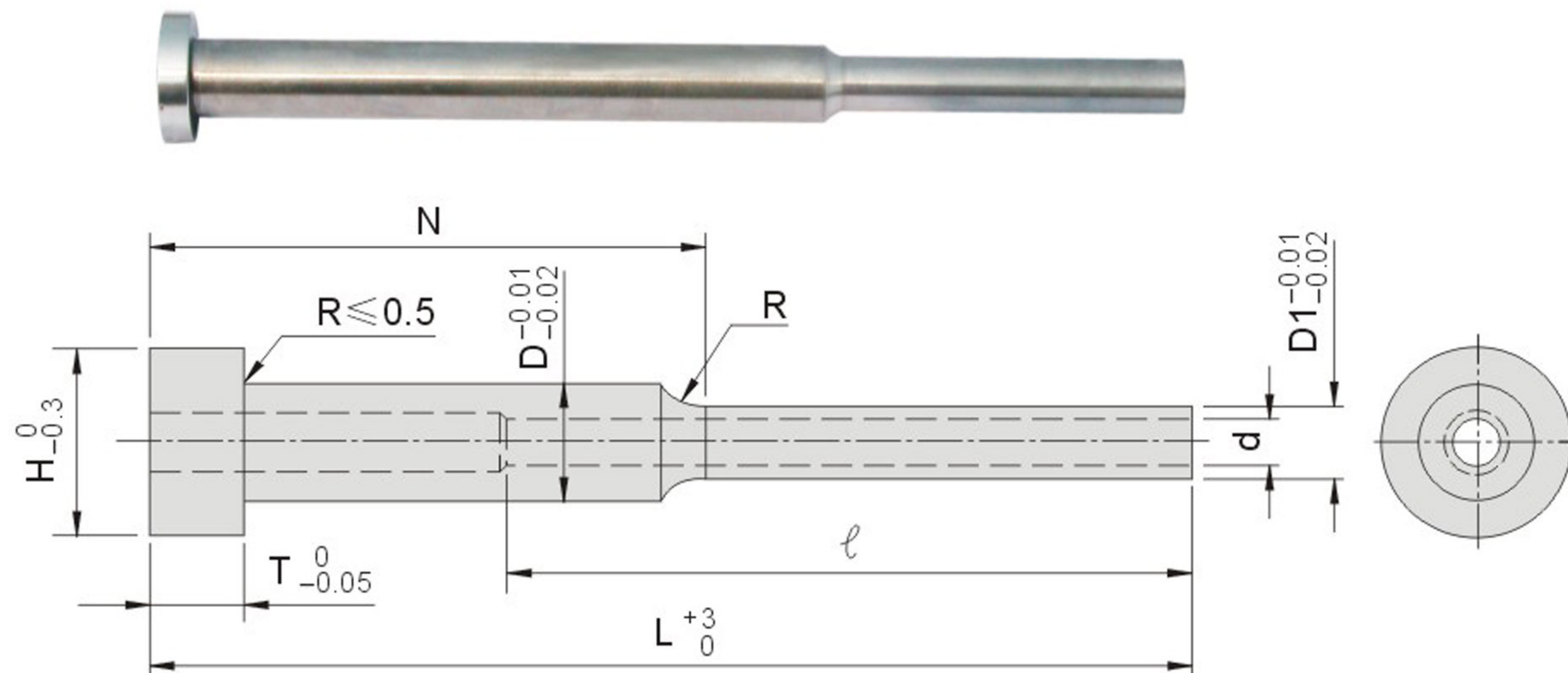

**M** 材質 FDAC  
**H** 內部硬度(Core) HRC38°~42°  
 表面硬度(Surface) HV900~

外徑1 D	頭徑 H 0 -0.3	頭厚 T 0 -0.05
3	6	4
3.5	7	4
4.0	8	6
4.5	9	
5.0	10	
5.5	11	
6.0	13	
6.5	11	8
7.0	13	
7.5	14	
8.0	15	
8.5	16	
9.0	17	
9.5	15	
10	16	
10.5	17	
11		
12		

公制: mm

Type	外徑2 D1 -0.01 -0.02	外徑1 D -0.01 -0.02	內孔 d H7	長度 L +3/0														
				100	150	200	250	300	350	400	450	500	550	600	650	700	750	800
GBHT	4	4.5-8	2	○	○	○	○	○										
			2.5	○	○	○	○	○										
	4.5	2/2.5	○	○	○	○	○	○										
		3	○	○	○	○	○	○										
	5	2/2.5/3	○	○	○	○	○	○	○	○								
		3.5	○	○	○	○	○	○	○									
	5.5	2/2.5/3	○	○	○	○	○	○	○	○	○							
		3.5	○	○	○	○	○	○	○	○								
	6	4	○	○	○	○	○	○	○									
		2/2.5/3	○	○	○	○	○	○	○	○	○							
		3.5	○	○	○	○	○	○	○	○	○							
		4	○	○	○	○	○	○	○	○								
	6.5	4.5	○	○	○	○	○	○	○	○								
		2/2.5/3	○	○	○	○	○	○	○	○	○							
		3.5/4/4.5	○	○	○	○	○	○	○	○	○							
	7	5	○	○	○	○	○	○	○	○								
		2.5/3/3.5	○	○	○	○	○	○	○	○	○							
		4/4.5/5	○	○	○	○	○	○	○	○	○							
	8	5.5	○	○	○	○	○	○	○	○								
		3/3.5/4	○	○	○	○	○	○	○	○	○	○	○	○	○	○	○	○
		4.5/5/5.5	○	○	○	○	○	○	○	○	○	○	○	○	○	○	○	○
	9	6	○	○	○	○	○	○	○	○								
		3.5/4/4.5	○	○	○	○	○	○	○	○	○	○	○	○	○	○	○	○
		5/5.5/6	○	○	○	○	○	○	○	○	○	○	○	○	○	○	○	○
10	6.5/7	○	○	○	○	○	○	○	○									
	3.5/4/4.5	○	○	○	○	○	○	○	○	○	○	○	○	○	○	○	○	
	5/5.5/6	○	○	○	○	○	○	○	○	○	○	○	○	○	○	○	○	
11	6.5/7	○	○	○	○	○	○	○	○									
	3.5/4/4.5	○	○	○	○	○	○	○	○	○	○	○	○	○	○	○	○	
	5/5.5/6	○	○	○	○	○	○	○	○	○	○	○	○	○	○	○	○	
	6.5/7/7.5	○	○	○	○	○	○	○	○	○	○	○	○	○	○	○	○	
			8	○	○	○	○	○	○	○	○	○	○	○	○	○	○	

Order: GBHT - D - D1 - d - N - ℓ - L - H - T - Q'TY

※超出以上尺寸或公差價格另計



# 頂針系列 Extrusion Series

**GSB A** 灌嘴A型 Sprue Bush A Type

塑膠模用標準零配件

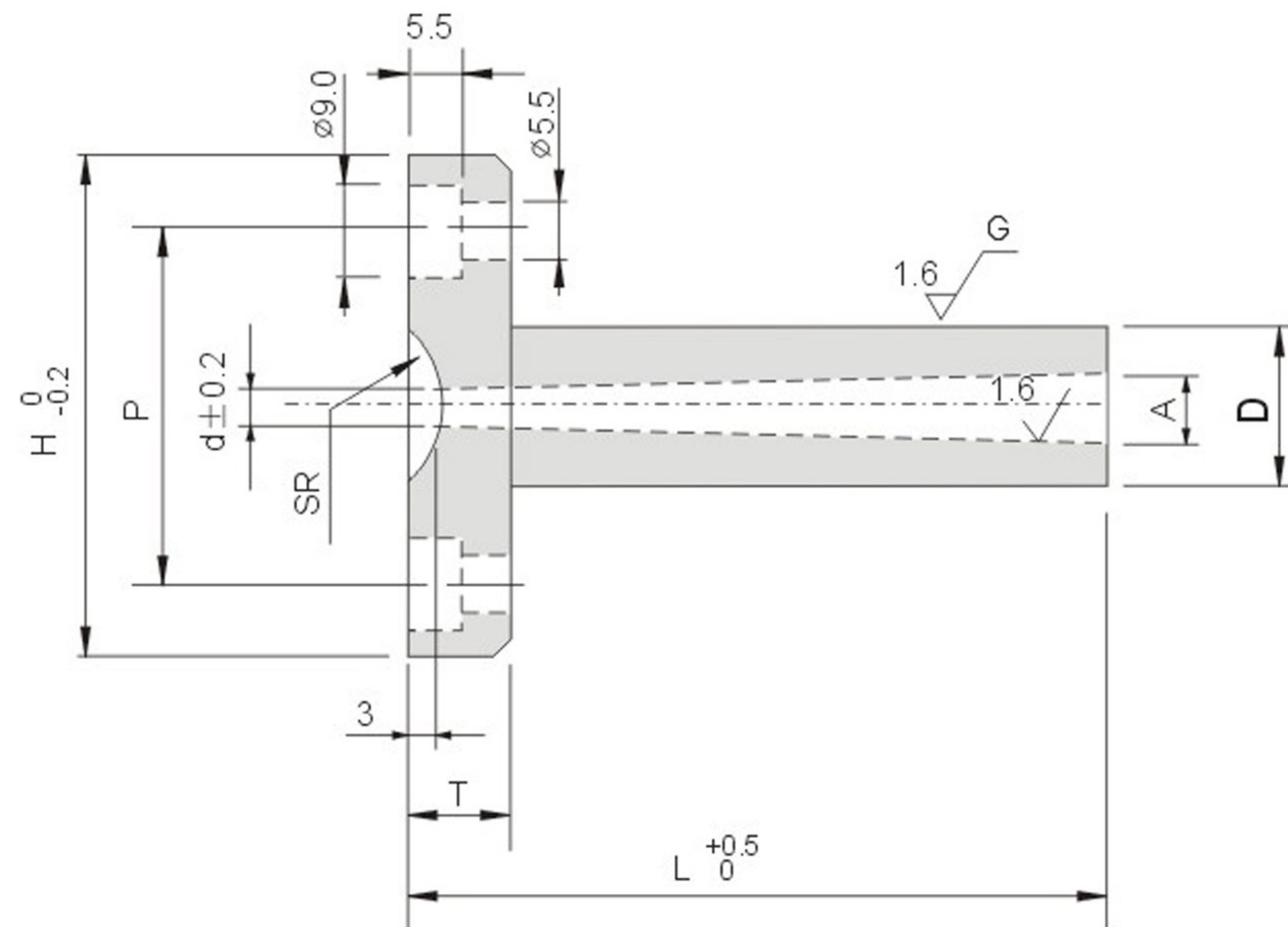

品名 Product	代號 Model	材質 Material	硬度 Hardened
45C灌嘴A型	<b>GSBCA</b>	S45C	SR部加硬HRC40°以上
WS灌嘴A型	<b>GSBUA</b>	SUJ2	HRC58°~62°
61灌嘴A型	<b>GSBSA</b>	SKD61	HRC48°~54°

(S45C)

公制: mm

Type No.	D	H	P	T	SR	d	A	L												
								40	50	60	70	80	90	100	110	120	130	140	150	
<b>GSBCA</b>	12	35	25	10	0	2.0	1°	○	○	○	○	○	○	○	○	○	○	○	○	○
	16			11	○			○	○	○	○	○	○	○	○	○	○	○	○	
				12	○			○	○	○	○	○	○	○	○	○	○	○	○	
<b>GSBUA</b>	20	50	36	20	13	2.5	2°	○	○	○	○	○	○	○	○	○	○	○	○	○
				3.0	○			○	○	○	○	○	○	○	○	○	○	○	○	
<b>GSBSA</b>	16	50	36	10	0	3.5	3°	○	○	○	○	○	○	○	○	○	○	○	○	○
				11	○			○	○	○	○	○	○	○	○	○	○	○		
	20			15	12	4.5	○	○	○	○	○	○	○	○	○	○	○	○	○	○
				13	○		○	○	○	○	○	○	○	○	○	○	○	○		
25	20	16	5.0	○	○	○	○	○	○	○	○	○	○	○	○	○	○	○		

Order: **GSBCA** - **D** - **L** - **Q'TY**



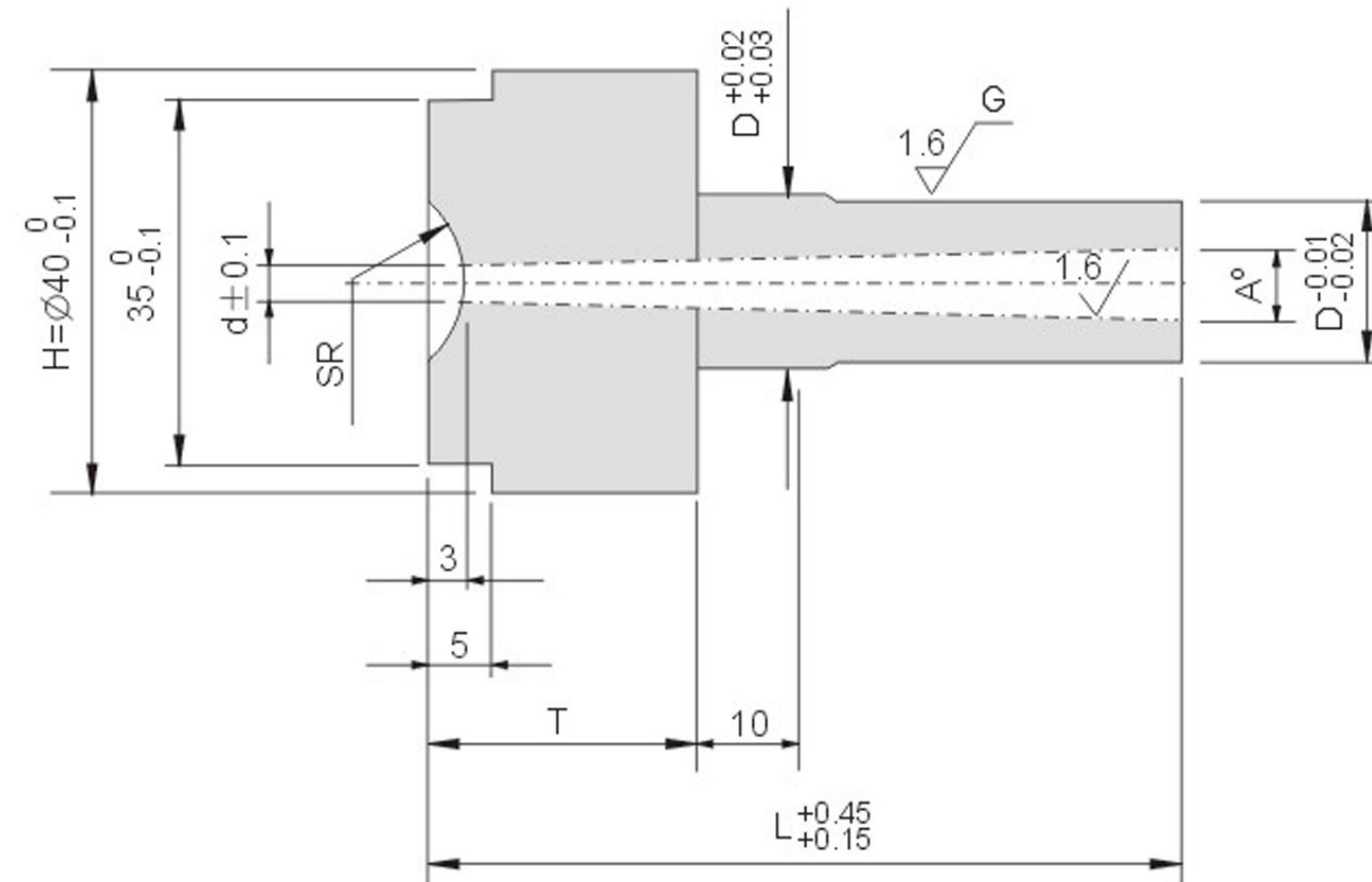

品名 Product	代號 Model	材質 Material	硬度 Hardened
45C灌嘴B型	<b>GSBCB</b>	S45C	SR部加硬HRC40°以上
WS灌嘴B型	<b>GSBUB</b>	SUJ2	HRC58°~62°
61灌嘴B型	<b>GSBSB</b>	SKD61	HRC48°~54°

(S45C)

公制：mm

Type No.	D		H	T	d	SR	A	L												
								40	50	60	70	80	90	100	110	120	130	140	150	
<b>GSBCB</b>	16	0 -0.011	40	20	2.0	0	1°	○	○	○	○	○	○	○	○	○	○	○	○	○
				25				○	○	○	○	○	○	○	○	○	○	○	○	○
				30				○	○	○	○	○	○	○	○	○	○	○	○	○
<b>GSBUB</b>	16	0 -0.011	40	3.5	13	11	2°	○	○	○	○	○	○	○	○	○	○	○	○	○
				4.0				○	○	○	○	○	○	○	○	○	○	○	○	○
<b>GSBSB</b>	20	0 -0.013	40	20	4.0	16	3°	○	○	○	○	○	○	○	○	○	○	○	○	○
				4.5				○	○	○	○	○	○	○	○	○	○	○	○	
				5.0				○	○	○	○	○	○	○	○	○	○	○	○	○
<b>GSBSB</b>	20	0 -0.013	40	25	5.0	21	3°	○	○	○	○	○	○	○	○	○	○	○	○	○
				30				○	○	○	○	○	○	○	○	○	○	○	○	○



 Order: **GSBCB** - **D** - **L** - **Q'TY**



# 頂針系列 Extrusion Series

## GSBC 灌嘴C型 Sprue Bush C Type

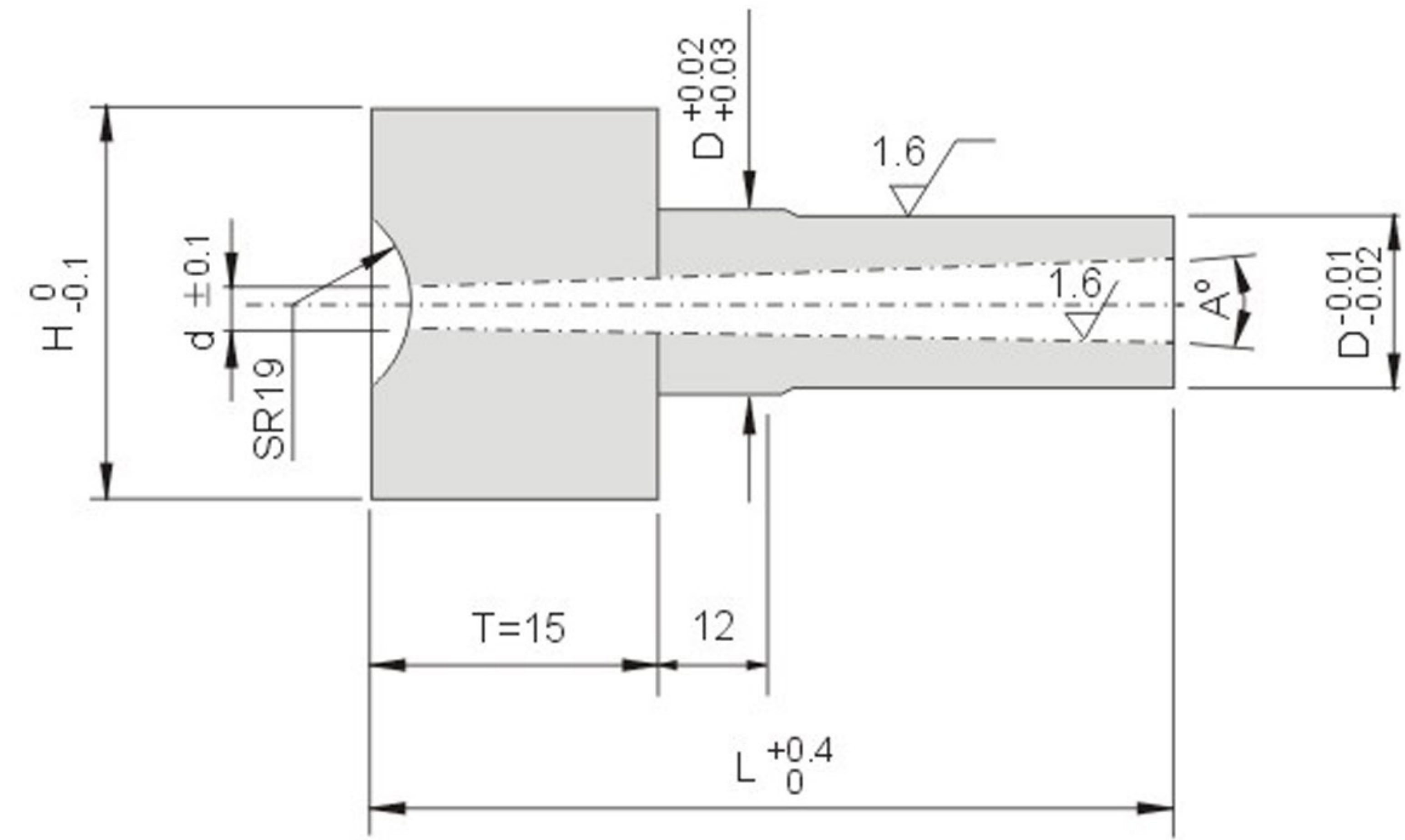
塑膠模用標準零配件



**M** 材質 S45C

**H** 硬度 SR部加硬HRC40°以上

公制: mm

Type No.	D	H	T	d	A°	L											
						50	60	70	80	90	100	110	120	130	140	150	
GSBC	12	25	15	2.0	1°	○	○	○	○	○	○	○					
				2.5													
				3.0													
	16	35		3.5		2°	○	○	○	○	○	○	○	○	○	○	○
				4.0		3°											
				4.5													
	20	35		5.0			○	○	○	○	○	○	○	○	○	○	○

Order: **GSBC** - **D** - **L** - **Q'TY**



GLRA

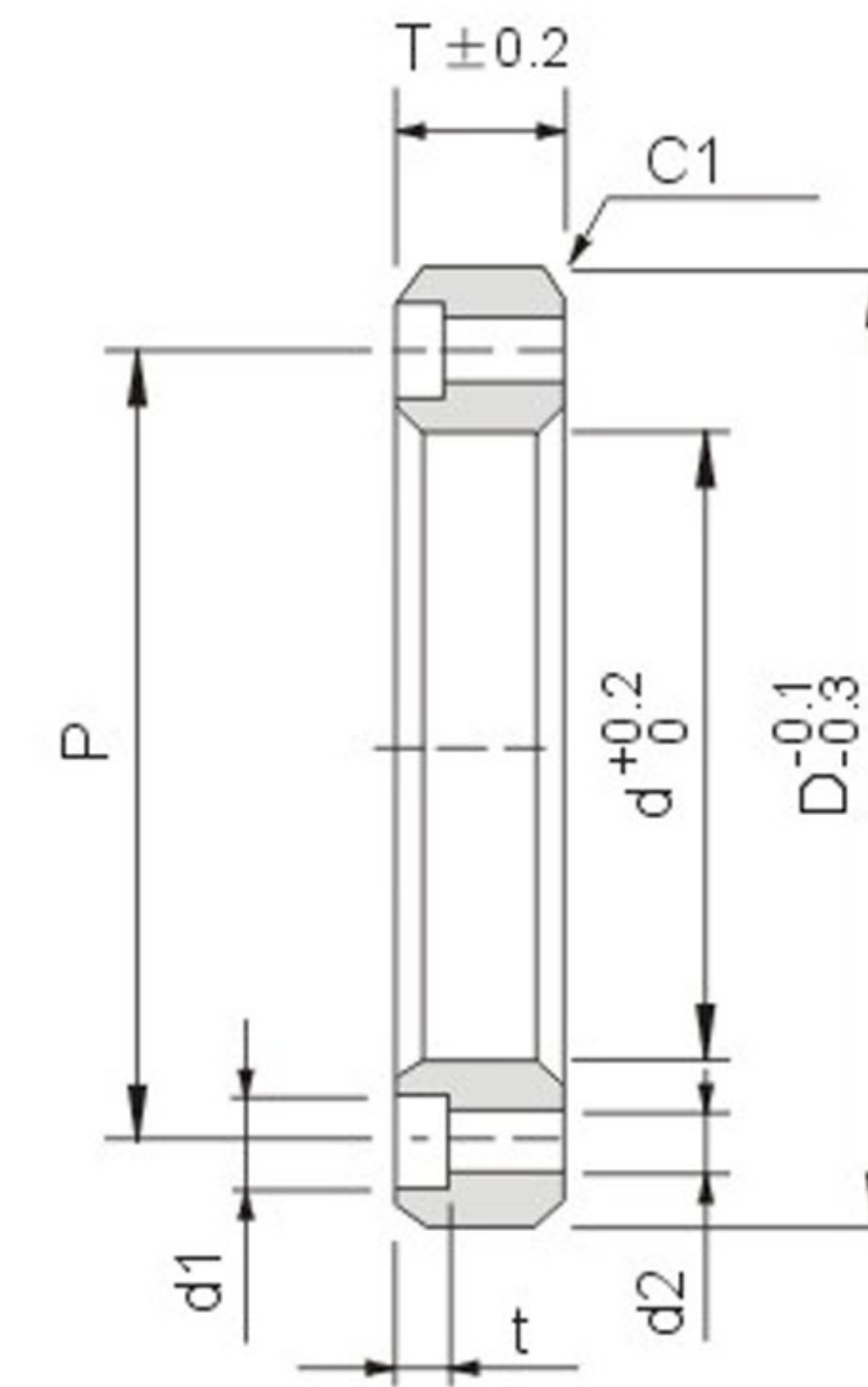
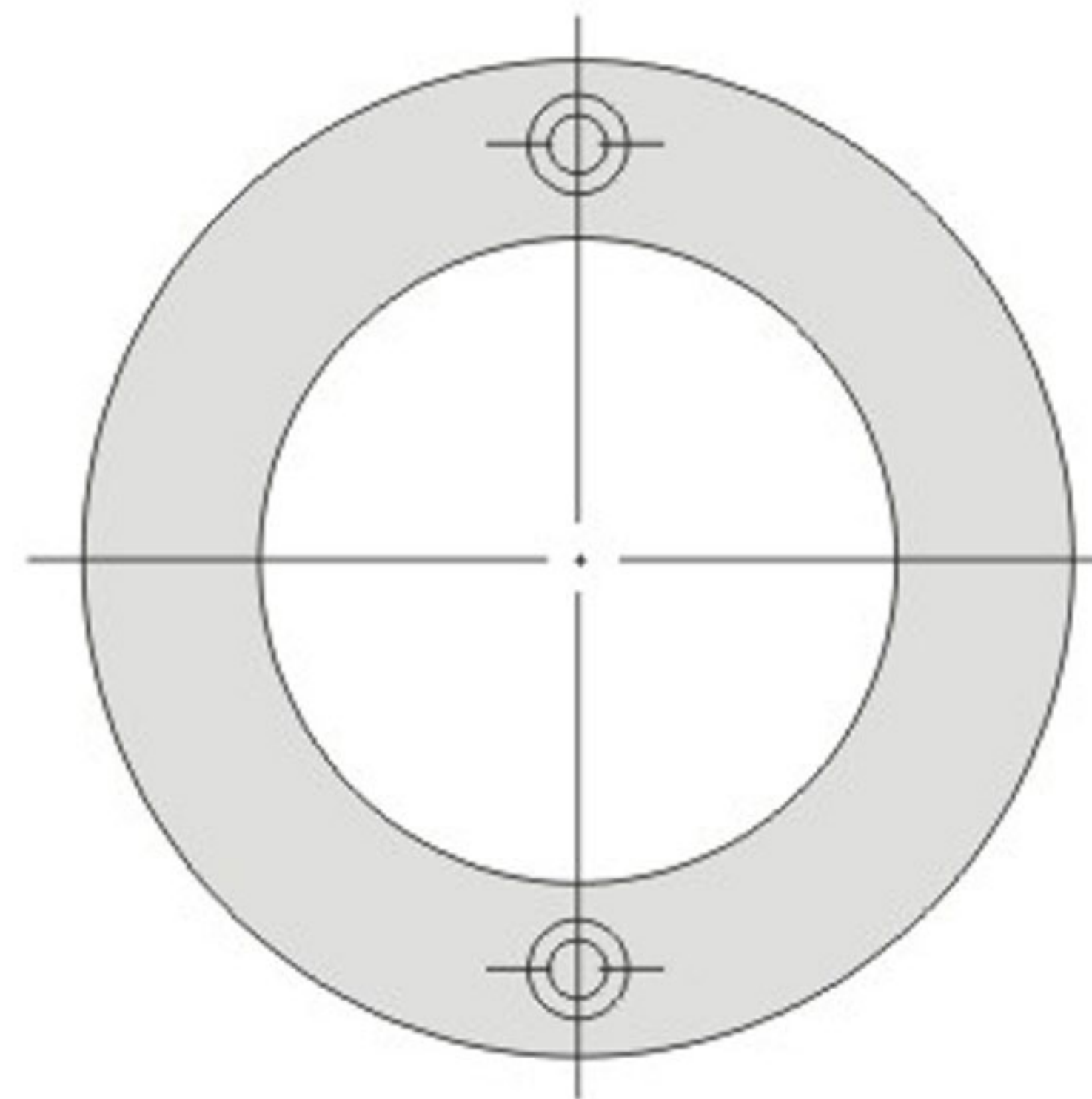

GLRB

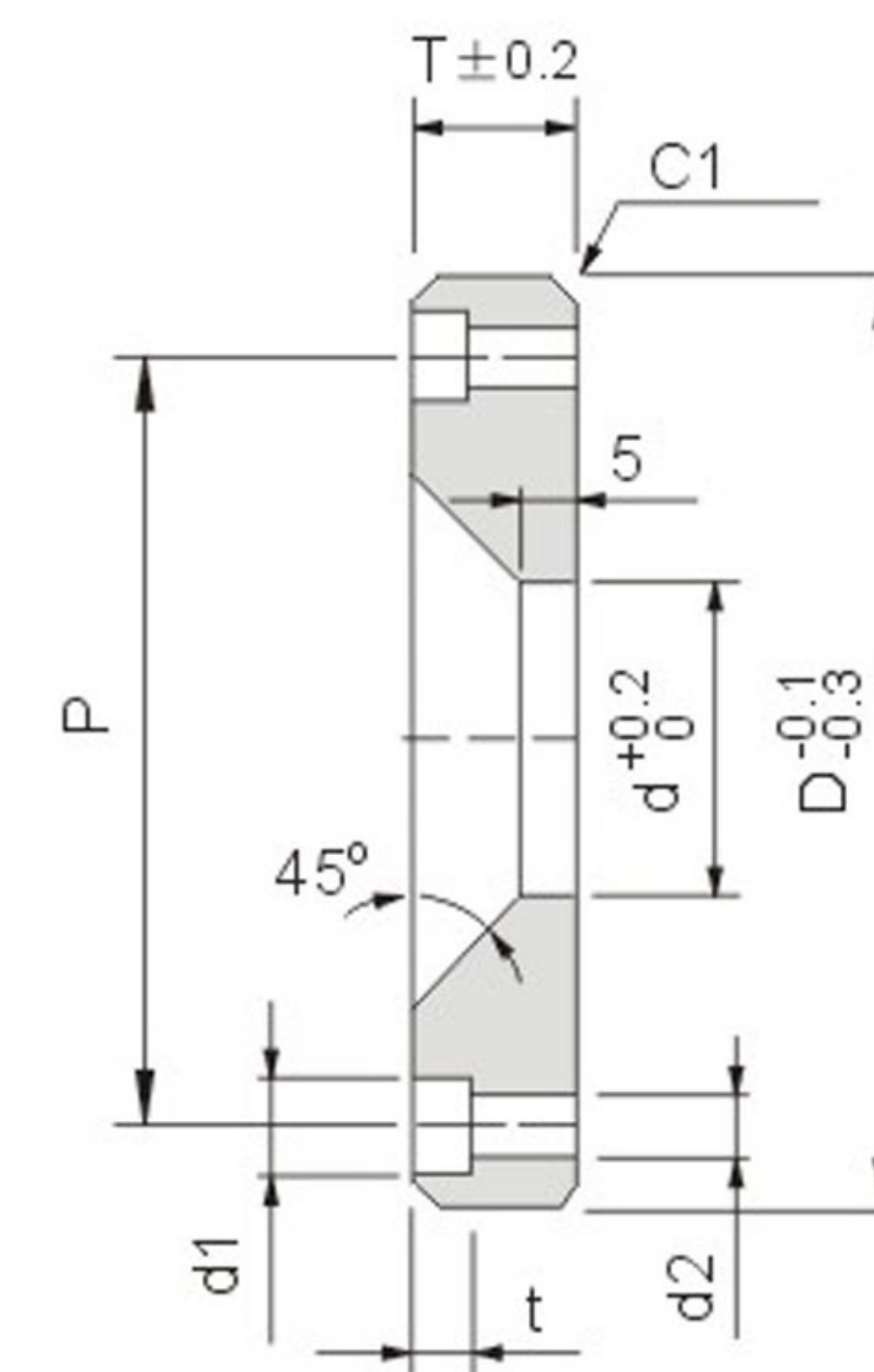
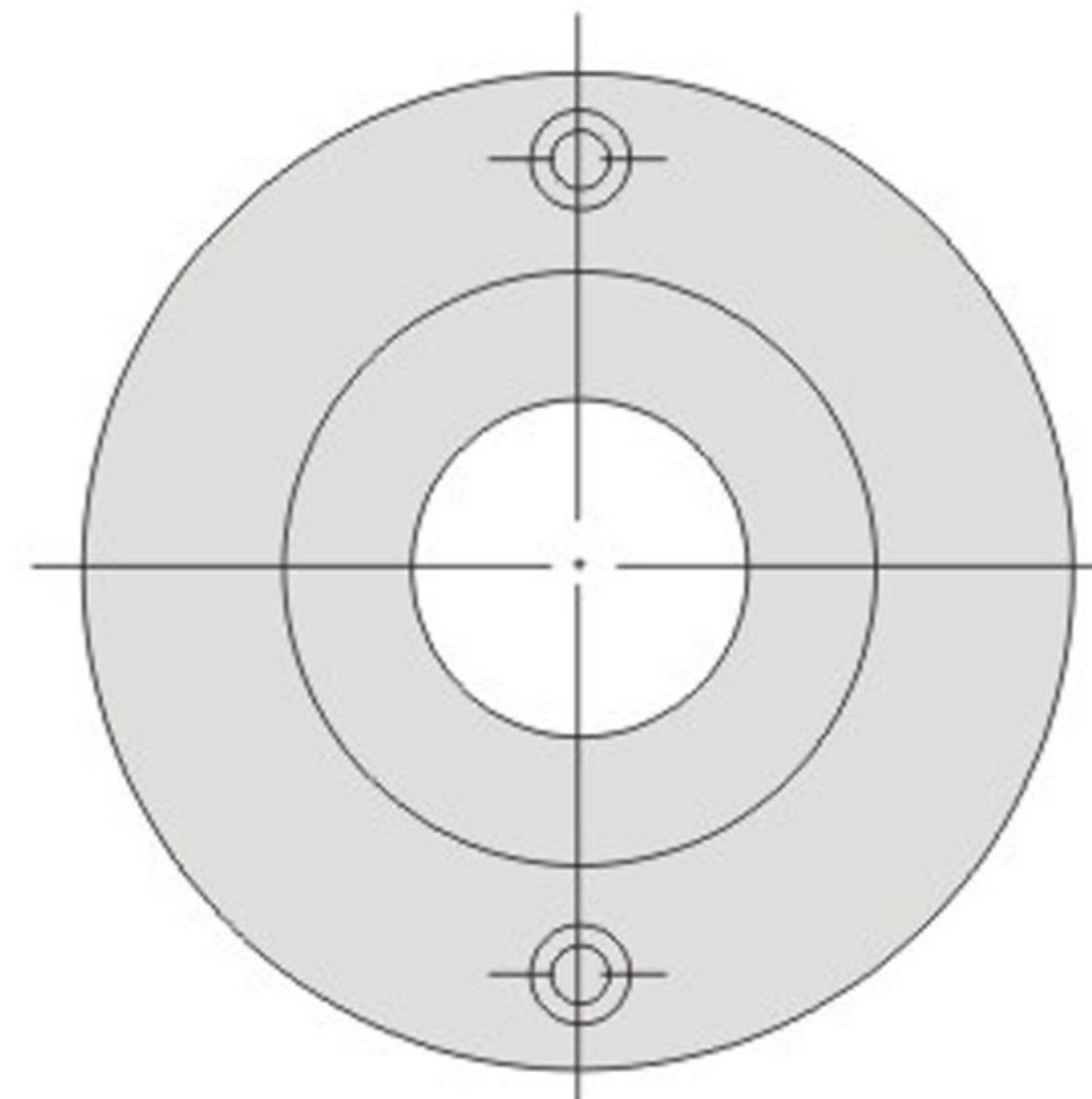
**M** 材質 S45C

Price:(HKD)

公制: mm

Type	D	T	P	t	d1	d2	d	單價 U'price
GLRA	60	15	48	4.5	7.5	5	35	○
	100	15	85	7	11	7	70	○
	120	15	105	7	11	7	90	○
	150	20	130	9	15	9	110	○

Price:(HKD)

Type	D	T	P	t	d1	d2	d	單價 U'price
GLRB	100	15	85	7	11	7	35	○
							50	
	120	15	105	7	11	7	35	○
							50	



Order: GLRA - D - T - Q'TY



# 頂針系列 Extrusion Series

**GSD**

小拉杆A型 Puller Bolt A Type

塑膠模用標準零配件

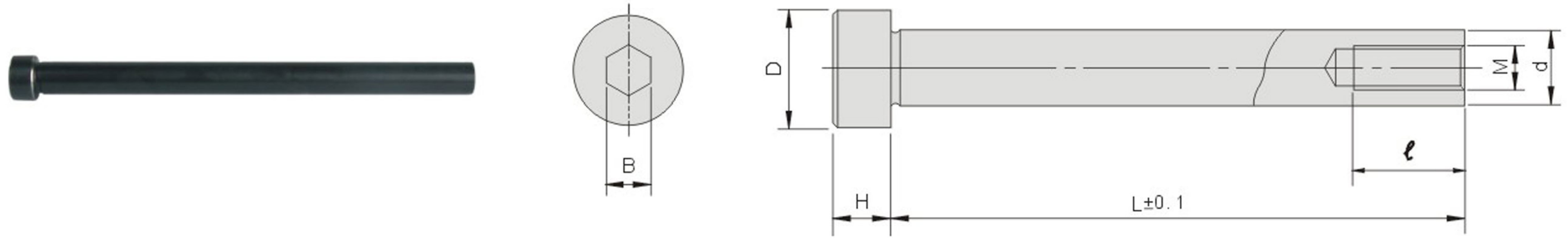

**M** 材質 SCM435

**H** 硬度 HRC38°~44°

D 容許差		H 容許差		Type No.		M	ℓ	B	
				Type	d 容許差				
16	0 -0.43	8	0 -0.36	GSD	10	0 -0.15	M6	12	6
18		10			13		M8	23	8
24	14	0 -0.43	16		M10		25	10	
28			20		M12	30	14		
33	0 -0.62	18	25		0 -0.20	M16	35	17	

L \ d	13	16	20
80	○	○	
90	○	○	
100	○	○	○
110	○	○	○
120	○	○	○
130	○	○	○
140	○	○	○
150	○	○	○
160	○	○	○
170	○	○	○
180	○	○	○
190	○	○	○
200	○	○	○
210	○	○	○
220	○	○	○
230	○	○	○
240	○	○	○
250	○	○	○
260	○	○	○
270	○	○	○
280	○	○	○

Order: **GSD** - **d** - **L** - Q'TY



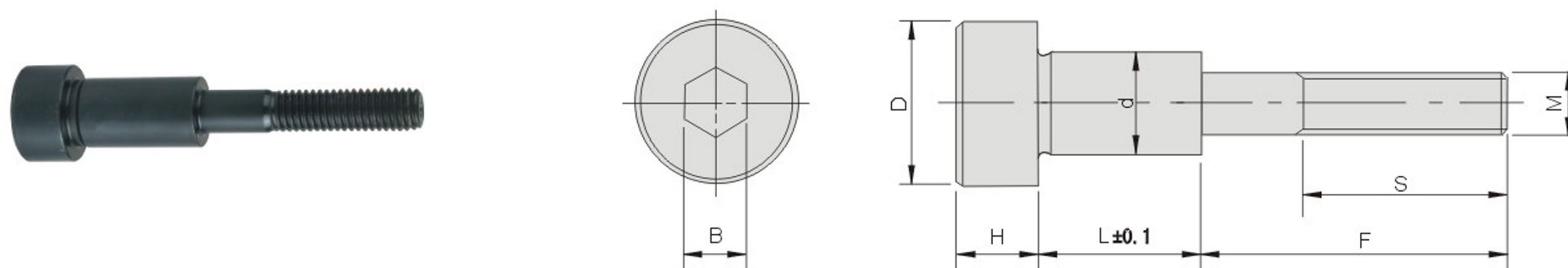

**M** 材質 SCM435

**H** 硬度 HRC38°~44°

D 容許差		H 容許差		Type No.		M	S	B	L	F	單價 U'price	
				Type	d 容許差							
16		8		GSB	10	M6	18	6	16	22	○	
									21	27	○	
18	0 -0.43	10	0 -0.36		13	0 -0.15	M8	24	8	14	30	○
										19	35	○
										24	40	○
24		14	0 -0.43		16		M10	26	10	15	35	○
										20	40	○
										30	45	○
28	0 -0.52	14	0 -0.43		20	0 -0.20	M12	30	14	20	45	○
										30	50	○
				35						55	○	
33	0 -0.62	18		25		M16	38	17	31	60	○	
									41	65	○	

Order: GSB - d - L - Q'TY



# 頂針系列 Extrusion Series

**GRP**

拉料銷(一般式) Runner Lock Pins

塑膠模用標準零配件

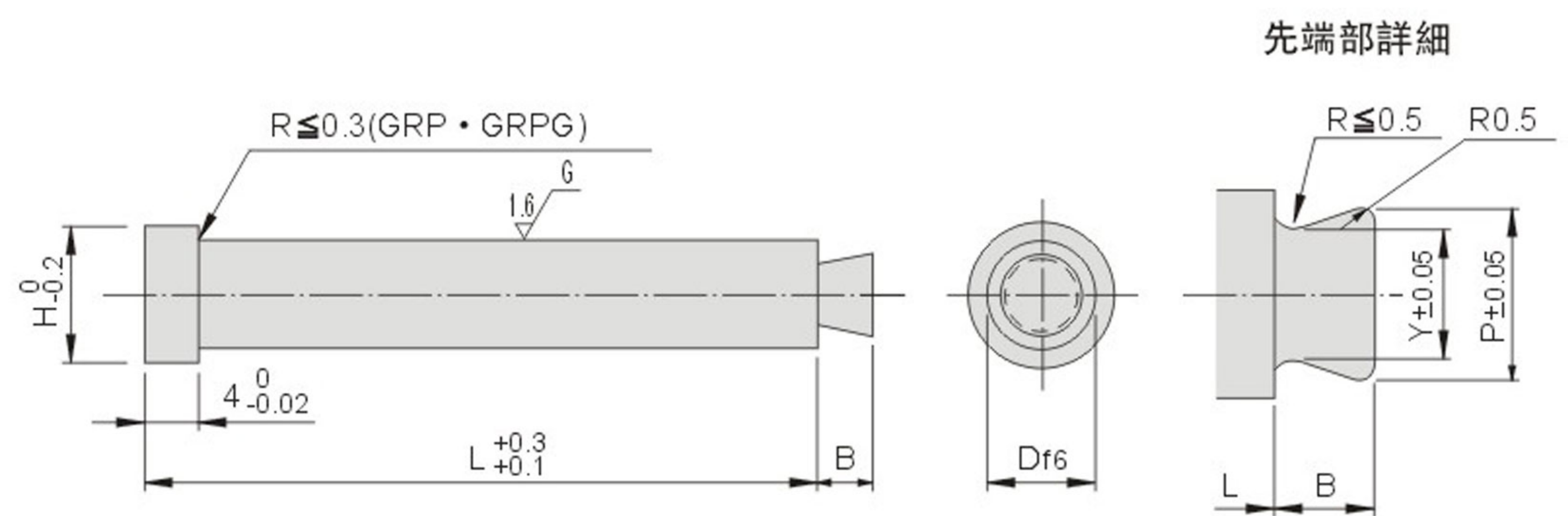

材質 SKH51

硬度 HRC61°~64°

H	B	P	Y	Type No.		L												
					D	15	20	25	30	35	40	45	50	60	70	80		
4	2	1.5	1.0	GRP	2	○	○	○	○	○	○							
5		2.3	1.8		3	○	○	○	○	○	○	○						
6	2.5	2.8	2.3		4	○	○	○	○	○	○	○	○	○	○	○	○	○
7		3.3	2.8		5	○	○	○	○	○	○	○	○	○	○	○	○	○
8	3	3.8	3.0		6	○	○	○	○	○	○	○	○	○	○	○	○	○
10		5.8	5.0		8				○	○	○	○	○	○	○	○	○	○

L寸法指定型

H	B	P	Y	Type No.		L 0.1mm單位
				Type	D	
4	2	1.5	1.0	GRPG	2	15.0~100.0
5		2.3	1.8		3	
6	2.5	2.8	2.3		4	
7		3.3	2.8		5	20.0~100.0
8	3	3.8	3.0		6	
10		5.8	5.0		8	

**GRN**

拉料銷(正規式) Runner Lock Pins

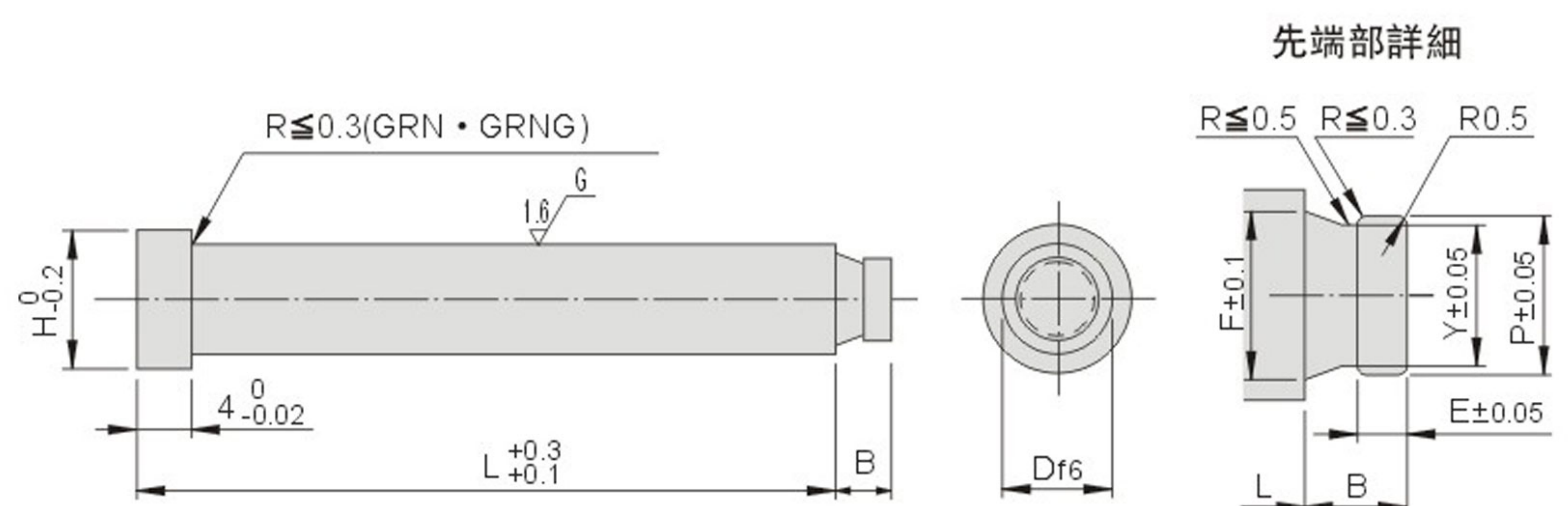

材質 SKH51

硬度 HRC61°~64°

H	B	E	P	Y	F	Type No.		L											
							D	15	20	25	30	35	40	45	50	60	70	80	
4	2	1	1.5	1.0	1.7	GRN	2	○	○	○	○	○	○						
5			2.3	1.8	2.5		3	○	○	○	○	○	○	○					
6	2.5		2.8	2.3	3.0		4	○	○	○	○	○	○	○	○	○	○	○	○
7		3	3.3	2.8	3.5		5	○	○	○	○	○	○	○	○	○	○	○	○
8	3		1.5	3.8	3.0		4.0	6	○	○	○	○	○	○	○	○	○	○	○
10		4		2	5.8		5.0	6.0	8	○	○	○	○	○	○	○	○	○	○

L寸法指定型

H	B	E	P	Y	F	Type No.		L 0.1mm單位
						Type	D	
4	2	1	1.5	1.0	1.7	GRNG	2	15.0~100.0
5			2.3	1.8	2.5		3	
6	2.5		2.8	2.3	3.0		4	
7		3	3.3	2.8	3.5		5	20.0~100.0
8	3		1.5	3.8	3.0		4.0	
10		4		2	5.8		5.0	



Order: GRP - D - L - Q'TY

※ 可接受圖面追加工  
(Special product is available)

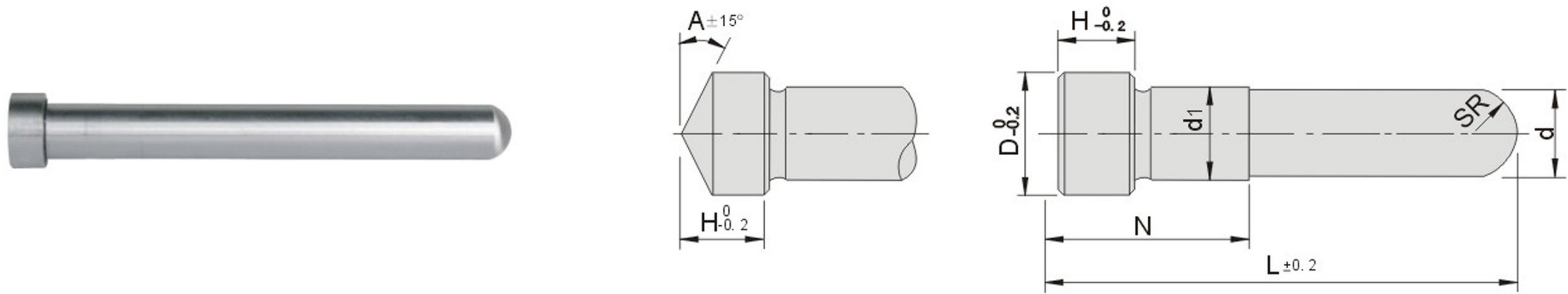

**M** 材質 SUJ2

**H** 硬度 HRC60° ± 2°

**S** 表面處理 高週波處理

公制: mm

Type No.				D	H	N
Type	d	d 容許差	d1 容許差			
GAP	10	-0.013 -0.022	+0.015 +0.006	13	8	19
	13	-0.016 -0.027	+0.018 +0.006	17	10	24
	16			20	12	29
	20	-0.020 -0.033	+0.021 +0.008	25	15	39
	25			30		49

Price:(HKD)

L	d							
	16	20	25	30	35	40	45	50
50	○	○						
60	○	○						
70	○	○	○	○				
80	○	○	○	○	○	○		
90	○	○	○	○	○	○		
100	○	○	○	○	○	○	○	○
110	○	○	○	○	○	○	○	○
120	○	○	○	○	○	○	○	○
130	○	○	○	○	○	○	○	○
140	○	○	○	○	○	○	○	○
150	○	○	○	○	○	○	○	○
160	○	○	○	○	○	○	○	○
170	○	○	○	○	○	○	○	○
180	○	○	○	○	○	○	○	○
190	○	○	○	○	○	○	○	○
200	○	○	○	○	○	○	○	○
210	○	○	○	○	○	○	○	○
220	○	○	○	○	○	○	○	○
230	○	○	○	○	○	○	○	○
240	○	○	○	○	○	○	○	○
250	○	○	○	○	○	○	○	○
260	○	○	○	○	○	○	○	○
270	○	○	○	○	○	○	○	○
280	○	○	○	○	○	○	○	○
290	○	○	○	○	○	○	○	○
300	○	○	○	○	○	○	○	○



Order: GAP - d - D - H - N - Q'TY



# 頂針系列 Extrusion Series

**GLN**

精密級導柱附(油溝式) Precision Leader Pins (With Oil Groove Type)

塑膠模用標準零配件



**M** 材質 SUJ2

**H** 硬度 HRC58° (高週波燒入)

公制: mm

D		Dm5		T	H	E
8	-0.015	8	+0.012	5	11	3
10	-0.020	10	+0.006		13	4
12	-0.020 -0.025	12	+0.015 +0.007		17	5
13		13		18		
16	-0.025 -0.030	16	+0.017 +0.008	21		
20		20		25		
25		25		30		
28	-0.030 -0.040	28	+0.020 +0.009	33	8	
30		30		35		
32	-0.030 -0.040	32	+0.024 +0.011	40		
35		35		45		
40		40		56		
50	-0.030 -0.050	50	+0.024 +0.011	12	8	
60		60		65		

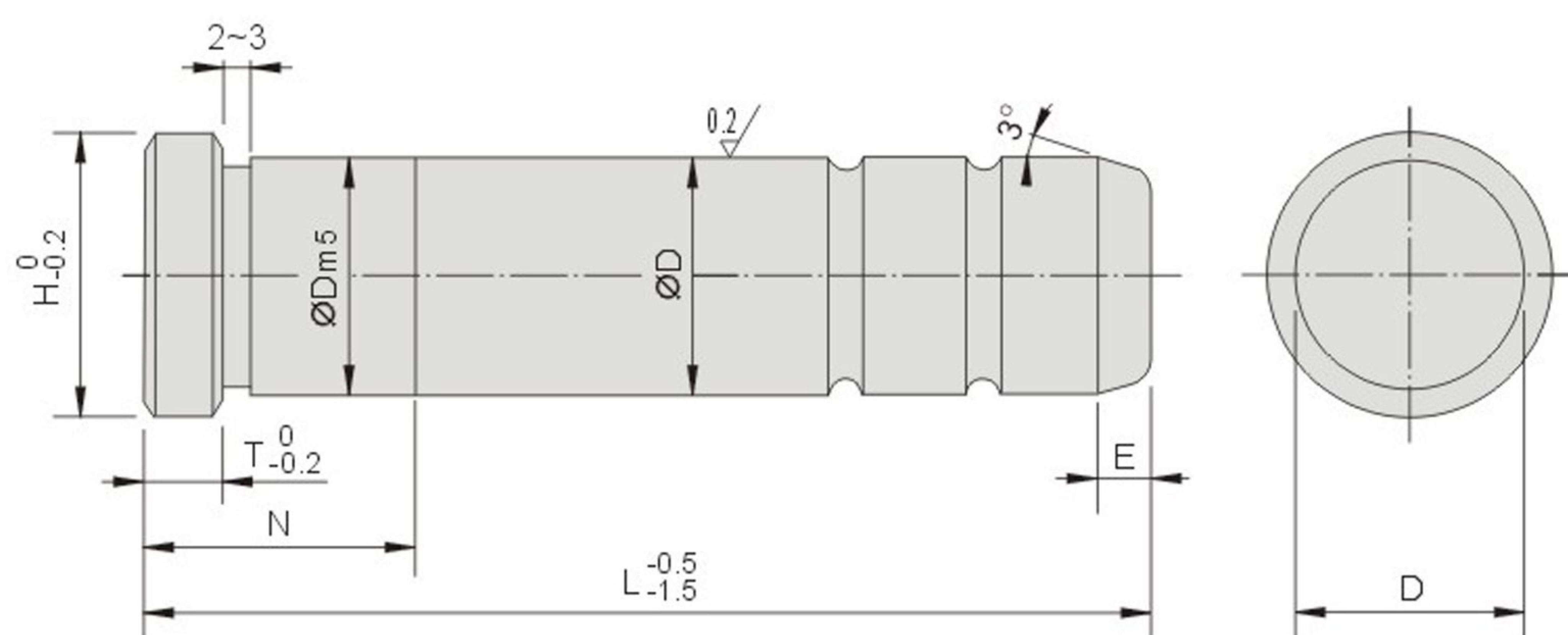

Type No.	L		N
Type	D		(1mm單位)
GLN	8	40 45	5 ~ 16
		50 55 60 65	5 ~ 24
		70	5 ~ 35
	10	40 45	5 ~ 16
		50 55 60 65	5 ~ 24
		70	5 ~ 35
	12	40 45	5 ~ 16
		50 55 60 65	5 ~ 24
		70 75	5 ~ 35
		80 85	5 ~ 45
		90 95	5 ~ 50
		100 105	5 ~ 60
110 115		5 ~ 70	
120 125 130 135 140 145 150 160		5 ~ 80	
13	40	6 ~ 16	
	45	6 ~ 16	
	50 55 60 65	6 ~ 24	
	70 75	6 ~ 35	
	80	6 ~ 45	
	85	6 ~ 45	
	90 95	6 ~ 50	
	100 105	6 ~ 60	
	110 115	6 ~ 70	
	120	6 ~ 80	
	125 130 135 140 145 150 155 160	6 ~ 80	
	165 170 175 180 185 190 195 200	6 ~ 80	

Type No.	L		N
Type	D		(1mm單位)
GLN	16	40	6 ~ 16
		45	6 ~ 16
		50 55 60 65	6 ~ 24
		70 75	6 ~ 35
		80	6 ~ 45
		85	6 ~ 45
	20	90 95	6 ~ 50
		100 105	6 ~ 60
		110 115	6 ~ 70
		120	6 ~ 80
		125 130 135 140 145 150 155 160	6 ~ 80
		165 170 175 180 185 190 195 200	6 ~ 80
20	20	210 220 230 240 250	6 ~ 80
		50	6 ~ 24
		55	6 ~ 24
		60 65	6 ~ 30
		70 75	6 ~ 35
		80 85	6 ~ 40
		90	6 ~ 50
		95	6 ~ 50
		100 105	6 ~ 60
		110 115	6 ~ 70
		120 125	6 ~ 80
		130 135	6 ~ 90
20	20	140 145 150	6 ~ 100
		155 160 165 170 175 180 185 190 195 200	6 ~ 100
		210 220 230 240 250 260	6 ~ 100
		270 280 290 300	6 ~ 100



公制: mm

Type No.		L	N (1mm單位)
Type	D		
GLN	25	50 55	8 ~ 24
		60	8 ~ 30
		65	8 ~ 30
		70 75 80 85	8 ~ 40
		90 95	8 ~ 50
		100 105	8 ~ 60
		110	8 ~ 70
		115	8 ~ 70
		120 125	8 ~ 80
		130 135	8 ~ 90
		140 145	8 ~ 100
		150 155	8 ~ 110
		160	8 ~ 110
		165 170 175 180 185 190 195 200	8 ~ 120
		210 220 230 240 250 260	8 ~ 120
		270 280 290 300	8 ~ 120
		310 320 330 340 350	8 ~ 120
		28	50 55
	60 65		8 ~ 30
	70 75 80 85		8 ~ 40
	90 95		8 ~ 50
	100 105		8 ~ 60
	110 115		8 ~ 70
	120 125		8 ~ 80
	130 135		8 ~ 90
	140 145		8 ~ 100
	150 155		8 ~ 110
	160 165 170 175 180 185 190 195 200		8 ~ 120
	30		60
		65	8 ~ 30
		70 75	8 ~ 35
		80 85	8 ~ 45
		90 95	8 ~ 50
		100 105 110	8 ~ 60
		115	8 ~ 60
		120 125	8 ~ 70
130 135		8 ~ 80	
140 145		8 ~ 90	
150 155		8 ~ 100	
160		8 ~ 110	
165		8 ~ 110	
170 175 180 185 190 195 200		8 ~ 120	
210 220 230 240 250 260		8 ~ 120	
270 280 290 300		8 ~ 120	
310 320 330 340 350		8 ~ 120	
360 370 380 390 400		8 ~ 130	
32	70 75	8 ~ 35	
	80 85	8 ~ 45	
	90 95	8 ~ 50	
	100 105 110 115	8 ~ 60	
	120 125	8 ~ 70	
	130 135	8 ~ 80	
	140 145	8 ~ 90	
	150 155	8 ~ 100	
	160 165	8 ~ 110	
	170 175	8 ~ 120	
	180 185 190 195 200	8 ~ 120	
	210 220 230 240 250 260	8 ~ 130	
	270 280 290 300	8 ~ 130	
	310 320 330 340 350	8 ~ 130	

Type No.		L	N (1mm單位)
Type	D		
GLN	35	70 75	8 ~ 35
		80 85	8 ~ 45
		90 95	8 ~ 50
		100	8 ~ 60
		105 115	8 ~ 60
		120 125	8 ~ 70
		130 135	8 ~ 80
		140 145	8 ~ 90
		150 155	8 ~ 100
		160	8 ~ 110
		165	8 ~ 110
		170 175	8 ~ 120
		180 185 190 195 200	8 ~ 120
		210 220 230 240 250 260	8 ~ 130
		270 280 290 300 310 320 330	8 ~ 130
		340 350 360 370 380 390 400	8 ~ 130
		410 420 430 440 450	8 ~ 130
		40	100 105
	110 115		10 ~ 50
	120 125 130 135		10 ~ 60
	140		10 ~ 70
	145		10 ~ 70
	150 155 160 165 170 175		10 ~ 80
	180 185 190		10 ~ 90
	195		10 ~ 90
	200 210		10 ~ 100
	220 230		10 ~ 110
	240		10 ~ 120
	250		10 ~ 130
	260 270	10 ~ 130	
	280 290 300	10 ~ 130	
	310 320 330 340 350 360 370 380	10 ~ 140	
	390 400 410 420 430 440 450	10 ~ 140	
	460 470 480 490 500	10 ~ 140	
	50	120 125	12 ~ 50
		130 135	12 ~ 60
140 145		12 ~ 70	
150		12 ~ 80	
155 160 165 170 175 180 185		12 ~ 80	
190		12 ~ 90	
195 200		12 ~ 90	
210		12 ~ 100	
220 230		12 ~ 100	
240		12 ~ 110	
250		12 ~ 110	
260 270		12 ~ 120	
280		12 ~ 130	
290 300		12 ~ 140	
310 320		12 ~ 150	
330 340		12 ~ 160	
350		12 ~ 170	
360		12 ~ 180	
370 380	12 ~ 190		
390 400	12 ~ 190		
410 420 430 440 450 460	12 ~ 200		
470 480 490 500	12 ~ 200		
510 520 530 540 550	12 ~ 200		
60	200 210	12 ~ 90	
	220 230	12 ~ 100	
	240	12 ~ 110	
	250	12 ~ 110	
	260 270	12 ~ 120	
	280	12 ~ 130	
	290 300	12 ~ 140	
	310 320	12 ~ 150	
	330 340	12 ~ 160	
	350	12 ~ 170	
	360	12 ~ 180	
	370 380	12 ~ 190	
	390 400	12 ~ 190	
	410 420 430 440 450 460	12 ~ 200	
	470 480 490 500	12 ~ 200	
	510 520 530 540 550	12 ~ 200	

 Order: **GLN - D - L - N - Q'TY**

※ 價格備詢

※ 可接受圖面追加工

(Special product is available)



# 頂針系列 Extrusion Series

**GBD**

精密級襯套(凸緣式) Precision Leader Bushings (Flange Type)

塑膠模用標準零配件

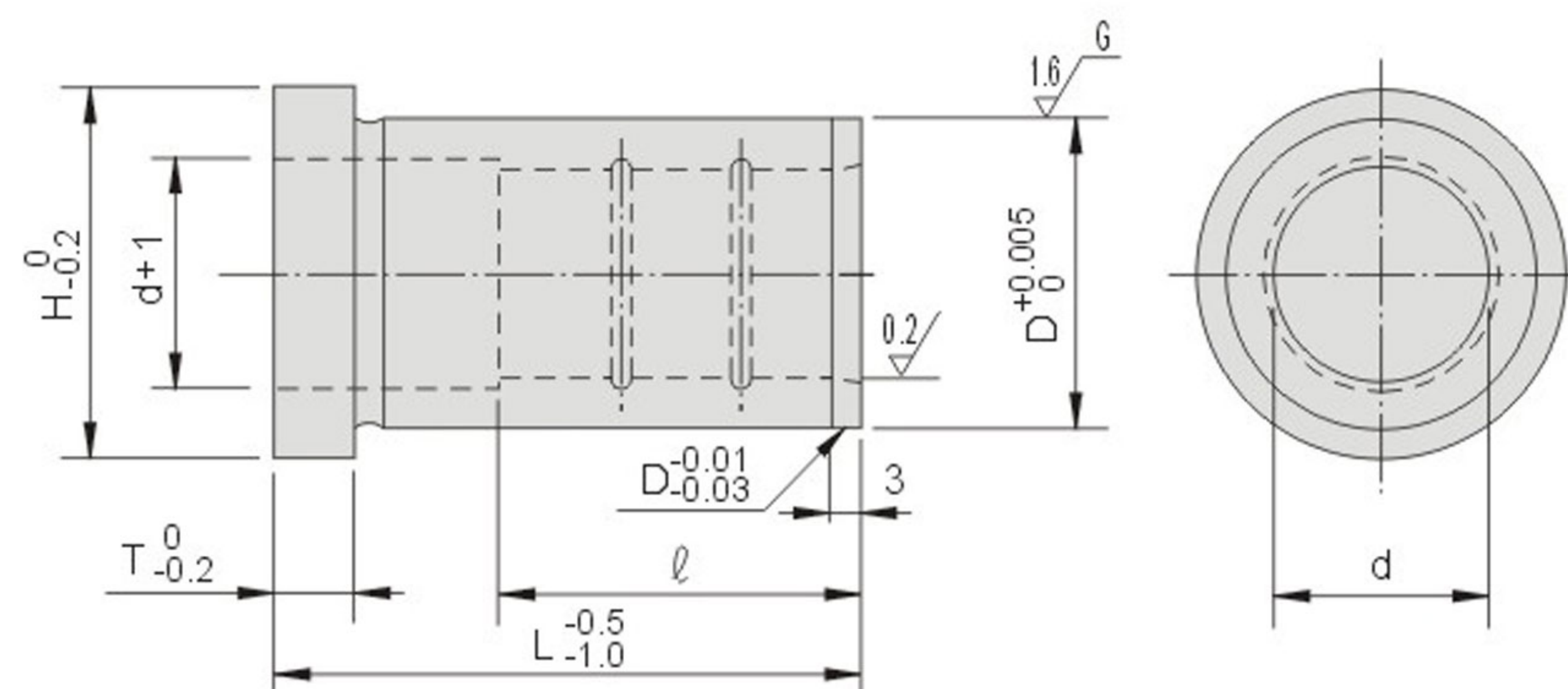

**M** 材質 SUJ2  
**H** 硬度 HRC58°

公制: mm

d	T	D	H	ℓ														
				L15	L20	L25	L30	L35	L40	L45	L50	L60	L70	L80	L90	L100		
8	0	12	14	15	15	15	-	-	-	-	-	-	-	-	-	-	-	-
10	-0.005	14	16	15	20	20	20	20	20	20	-	-	-	-	-	-	-	-
12	-0.005 -0.010	18	22	15	20	25	25	25	25	25	25	25	-	-	-	-	-	-
13		20	25	15	20	25	25	25	25	25	25	25	-	-	-	-	-	-
16	-0.010 -0.015	25	30	-	20	25	30	35	30	30	30	30	-	-	-	-	-	-
20		30	35	-	20	25	30	35	40	40	40	40	40	40	40	40	40	40
25		35	40	-	-	25	30	35	40	45	50	50	50	50	50	50	50	50
28		40	45	-	-	25	30	35	40	45	50	56	56	56	56	56	56	56
30	-	42	47	-	-	25	30	35	40	45	50	60	60	60	60	60	60	60

Type No.			L													
Type	D	d	15	20	25	30	35	40	45	50	60	70	80	90	100	
GBD	12	8	○	○												
	14	10	○	○												
	18	12	○	○	○											
	20	13	○	○	○	○										
	25	16		○	○	○										
	30	20		○	○	○	○									
	35	25			○	○	○									
	40	28				○	○	○								
	42	30					○	○	○							
										○	○	○	○	○	○	○

※ 可接受圖面追加工  
 (Special product is available)

Order: GBD - D - d - L - Q'TY



# GBE

## 精密級襯套(直式) Precision Leader Bushings (straight Type)

塑膠模用標準零配件

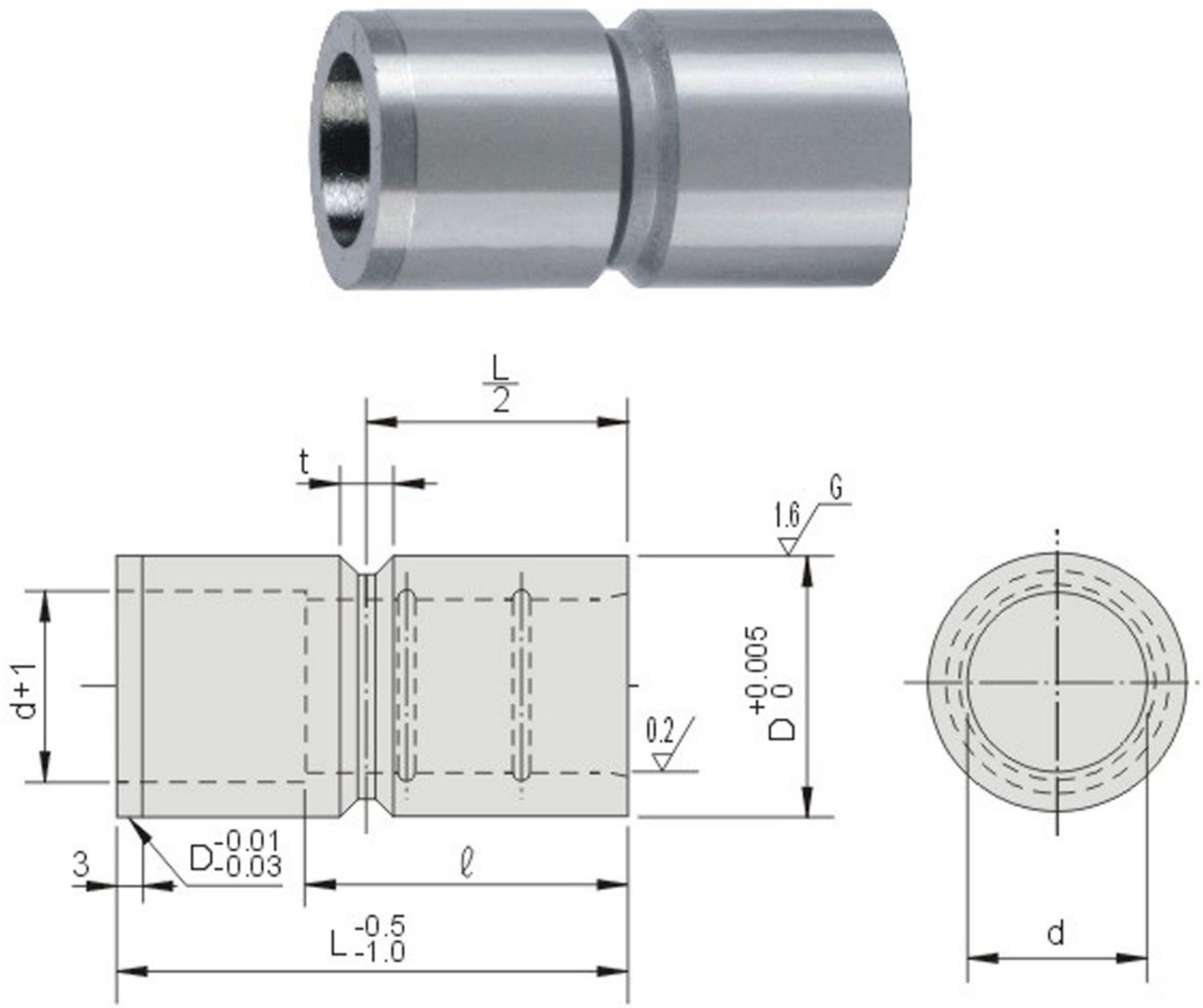

材質 SUJ2

硬度 HRC58°

※ 可接受圖面追加工

(Special product is available)

Order: GBE - D - d - L - Q'TY

Type No.		L											
Type	D	d	10	15	20	25	30	35	40	50	60	70	80
GBE	12	8	○	○	○								
	14	10				○	○						
	18	12	○	○	○								
	20	13	○	○	○	○		○	○				
	25	16		○	○	○		○	○		○	○	
	30	20		○	○	○	○		○	○	○		
	35	25			○	○	○	○		○	○	○	
	40	28				○	○	○		○	○	○	
	42	30					○	○	○	○		○	○

公制: mm

d	D	t	ℓ										
			L10	L15	L20	L25	L30	L35	L40	L50	L60	L70	L80
8	12	6	10	15	15	15	-	-	-				
10	14	6 (L=10→) t=4	10	15	20	20	20	20	20				
12	18		10	15	20	25	25	25	25				
13	20		10	15	20	25	25	25	25				
16	25	6		15	20	25	30	35	30	30			
20	30			15	20	25	30	35	40	40	40	40	
25	35	8			20	25	30	35	40	50	50	50	50
28	40					25	30	35	40	50	56	56	56
30	42					25	30	35	40	50	60	60	60

# GBF

## 襯套(配鋼珠套用) Ejector Ball Bushings (Ball Type)

公制: mm

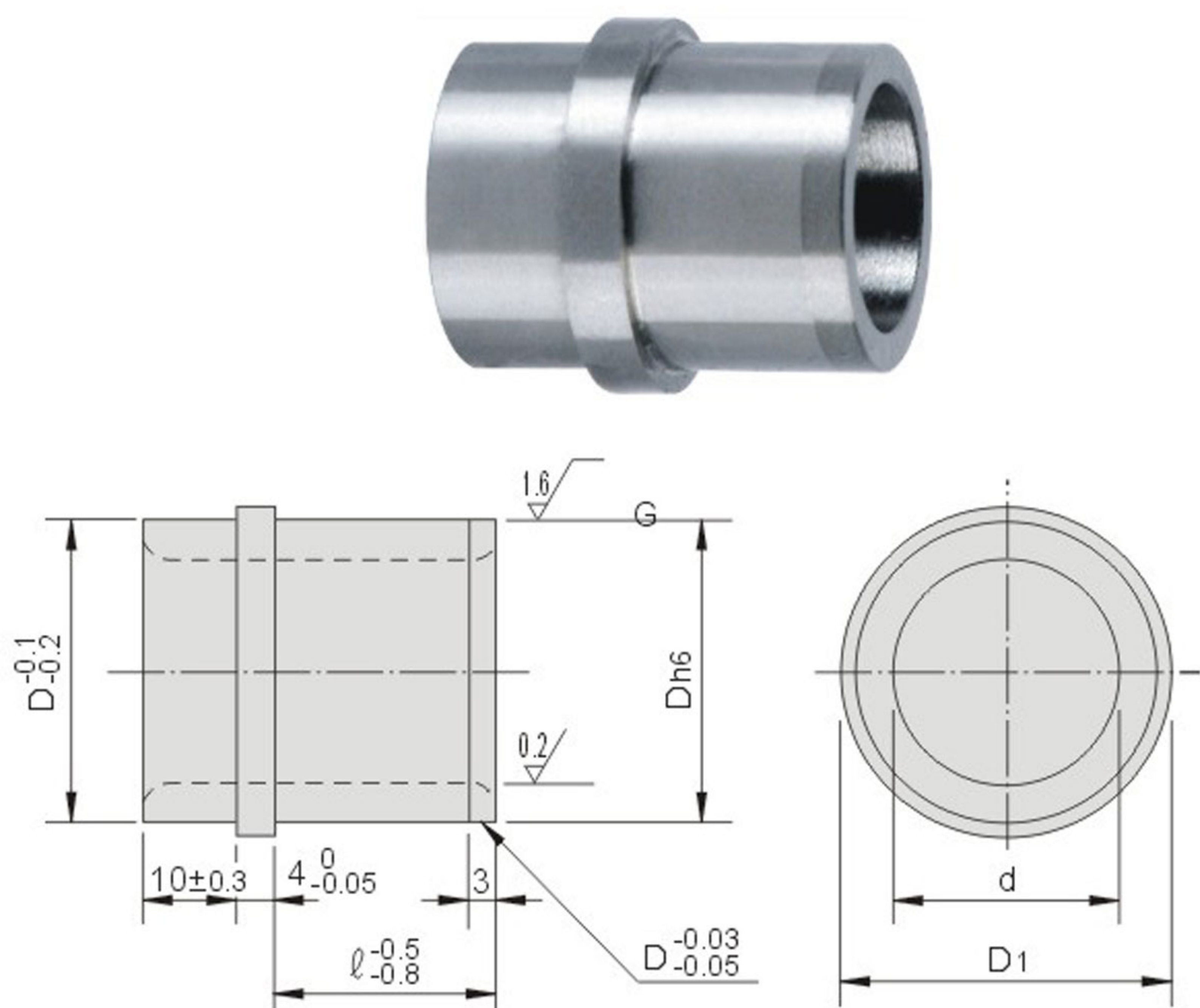

材質 SUJ2

硬度 HRC58°

D1	Dh6	d	Type No.		ℓ			
			Type	No.	13	15	20	25
19	16	12 -0.025 -0.030	GBF	8	○	○		
21	18			10	○	○		
25	22	17 -0.030 -0.035	GBF	13	○	○	○	○
28	25			16	○	○	○	○
33	30	24 -0.035 -0.040	GBF	20	○	○	○	○
38	35			25	○	○	○	○
43	40	34	GBF	30	○	○	○	○

Order: GBF - No. - ℓ - Q'TY



# 頂針系列 Extrusion Series

**GSPA**

停止銷 Stop Pins

塑膠模用標準零配件

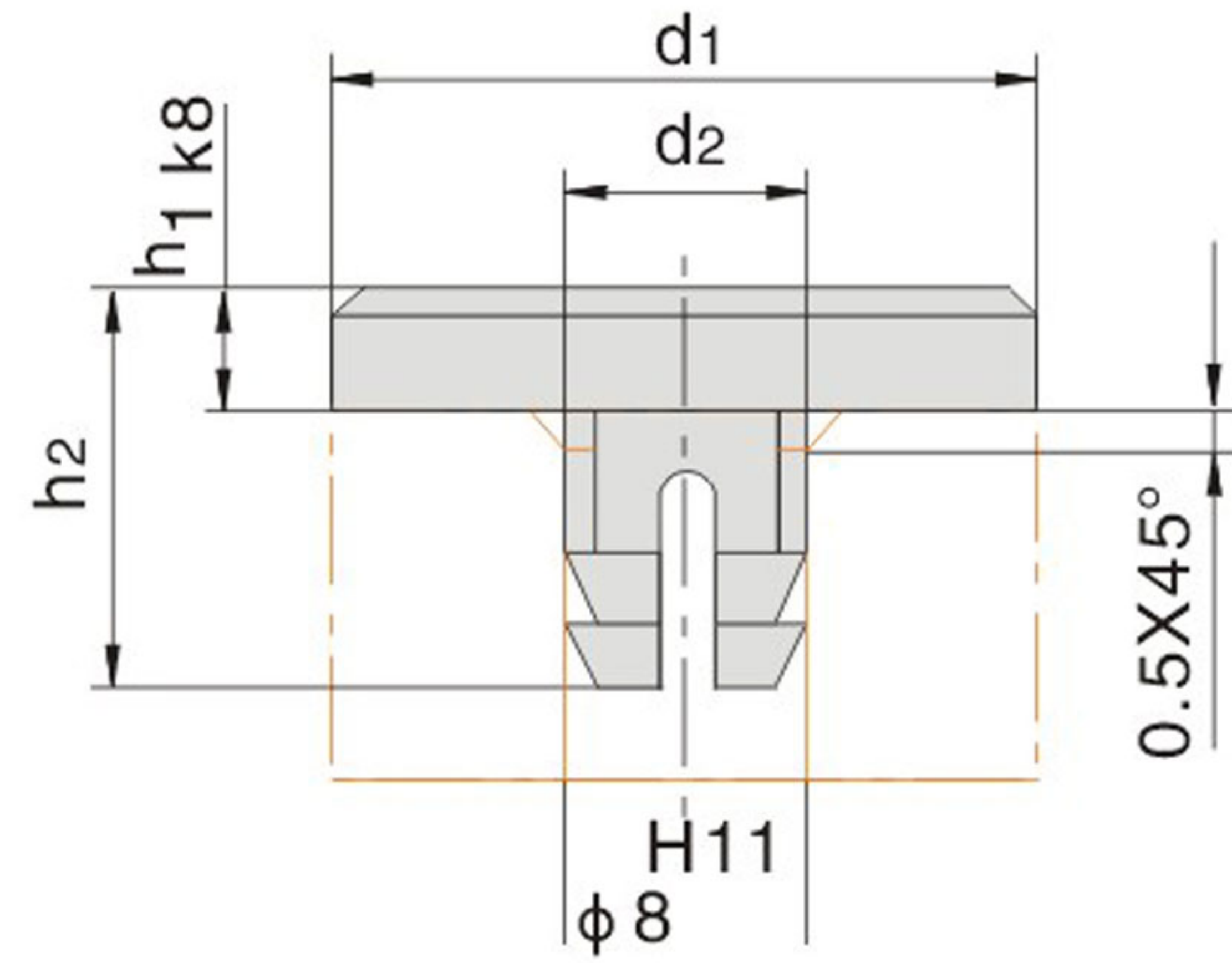

Nr./No.	h2	d2	d1	h1	单价(¥) Unit price
Z551/16 x 3	11	8.2	16	3	○
25 x 3			25		○

**GSPB**

停止銷 Stop Pins

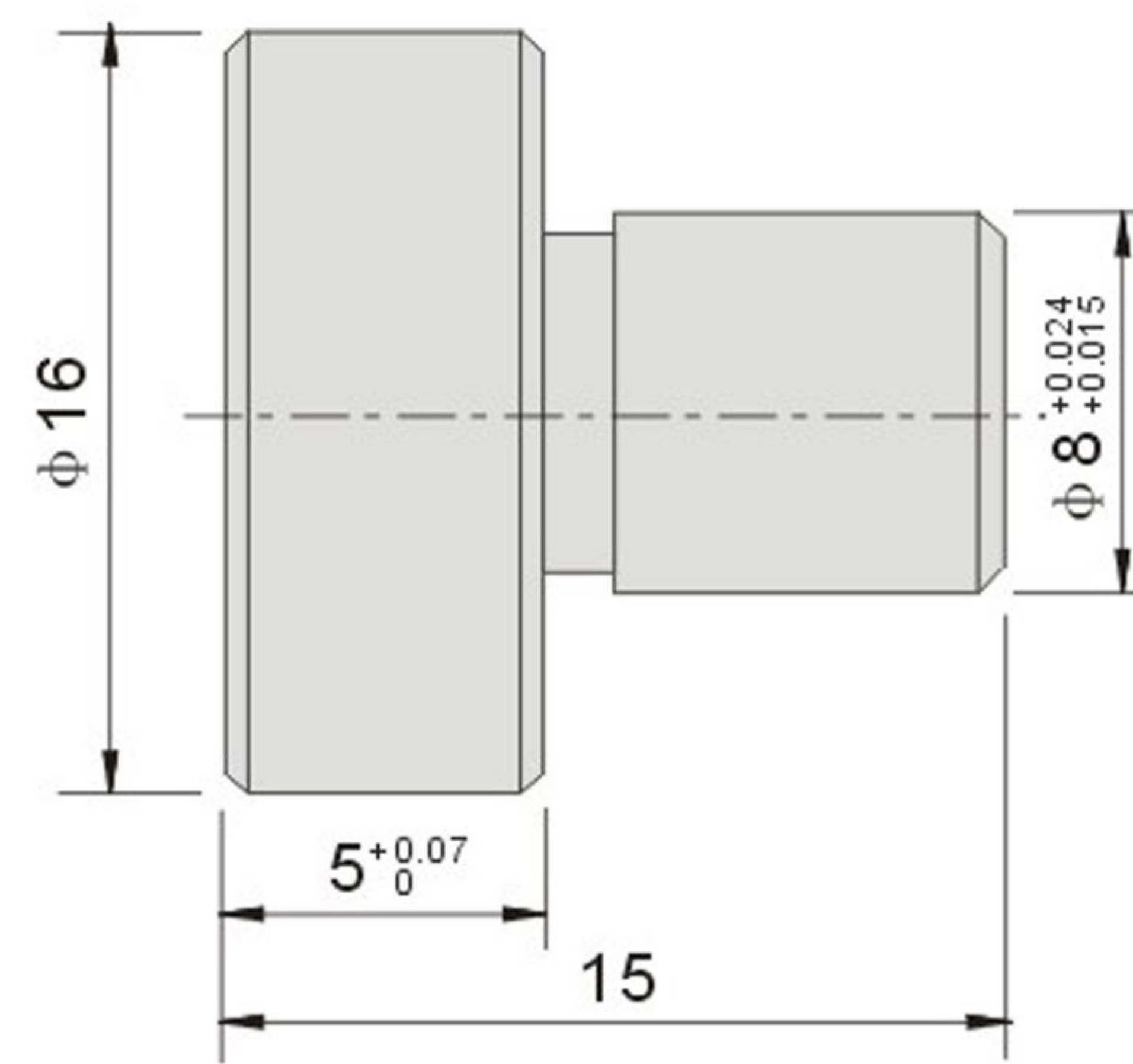

**GW**

汎用型華司・皿頭型華司 Washers

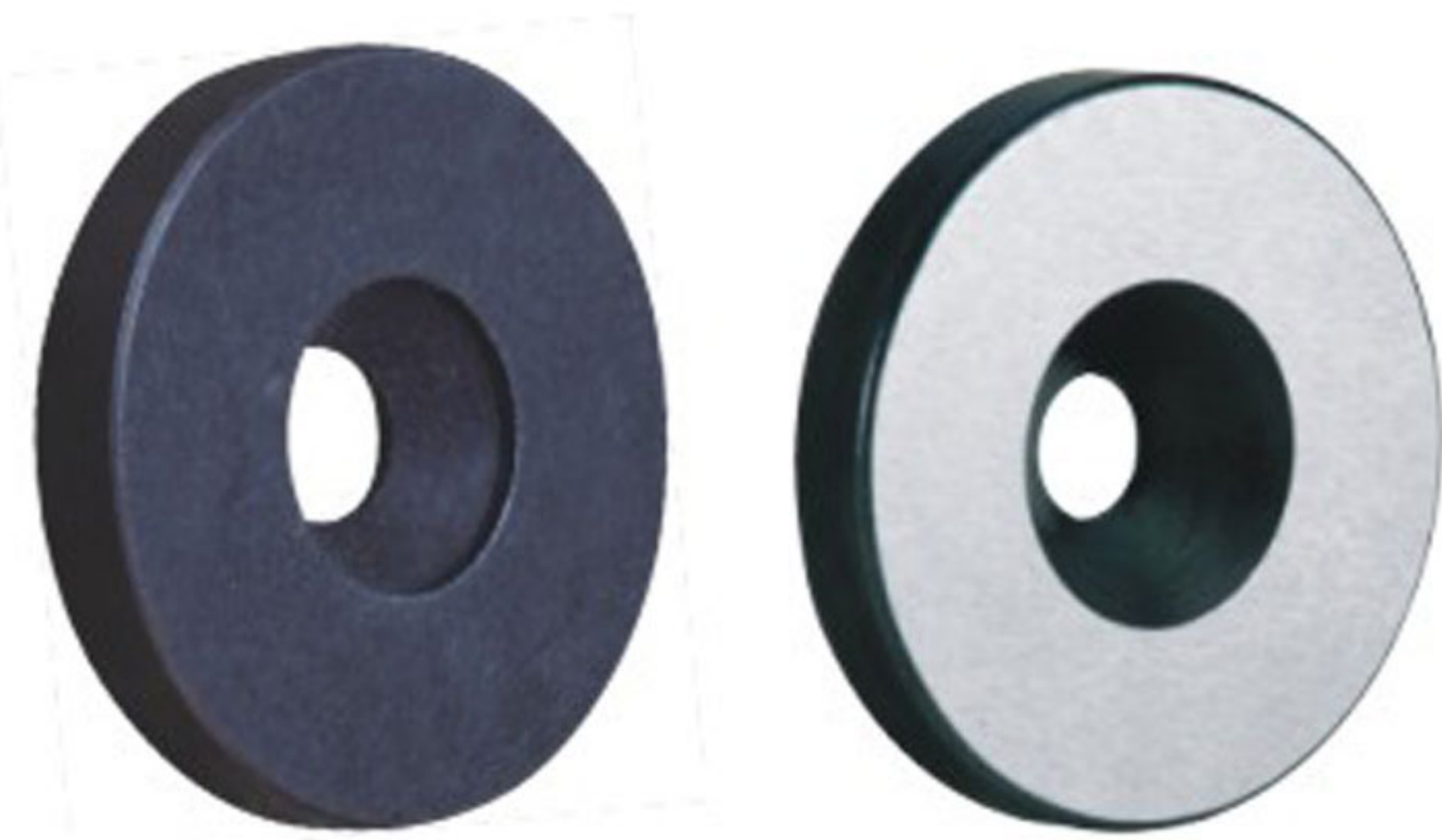

发黑处理，  
适合库存！

材質 S45C

硬度 HRC46°~50°

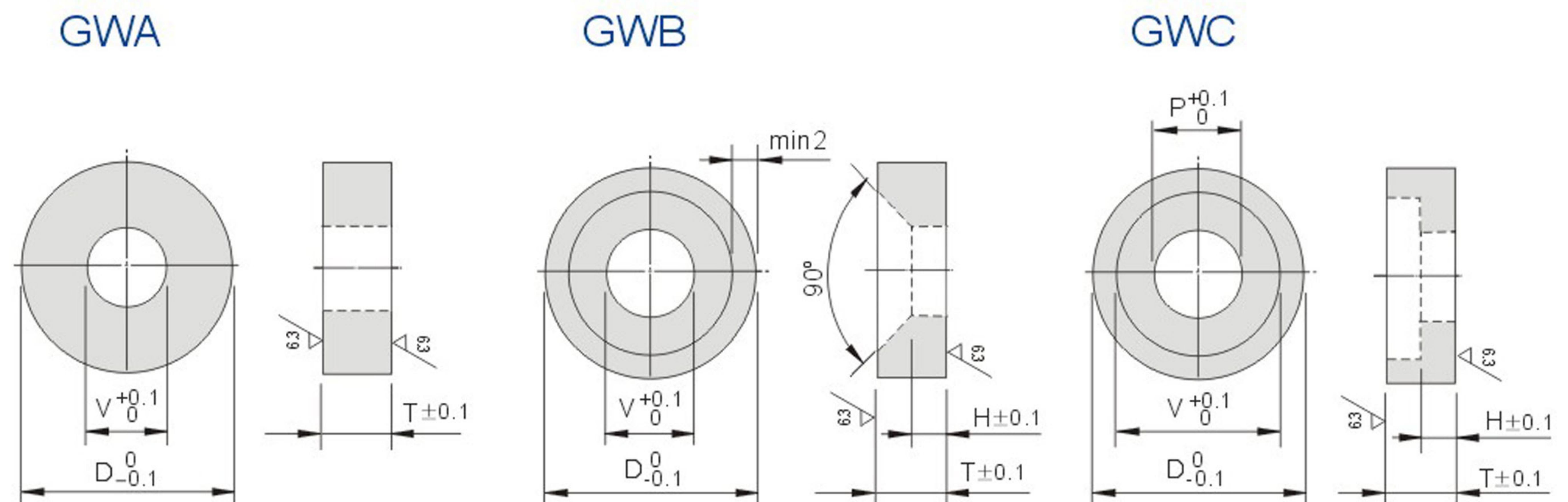

D	φ 16	φ 20	φ 25	φ 30	φ 18	φ 28
H	5	5	5	5	3	3
螺丝	M5	M6	M6	M8	M4	M4
单价(¥)	○	○	○	○	○	○



# GSH

## 支撐柱 Shore

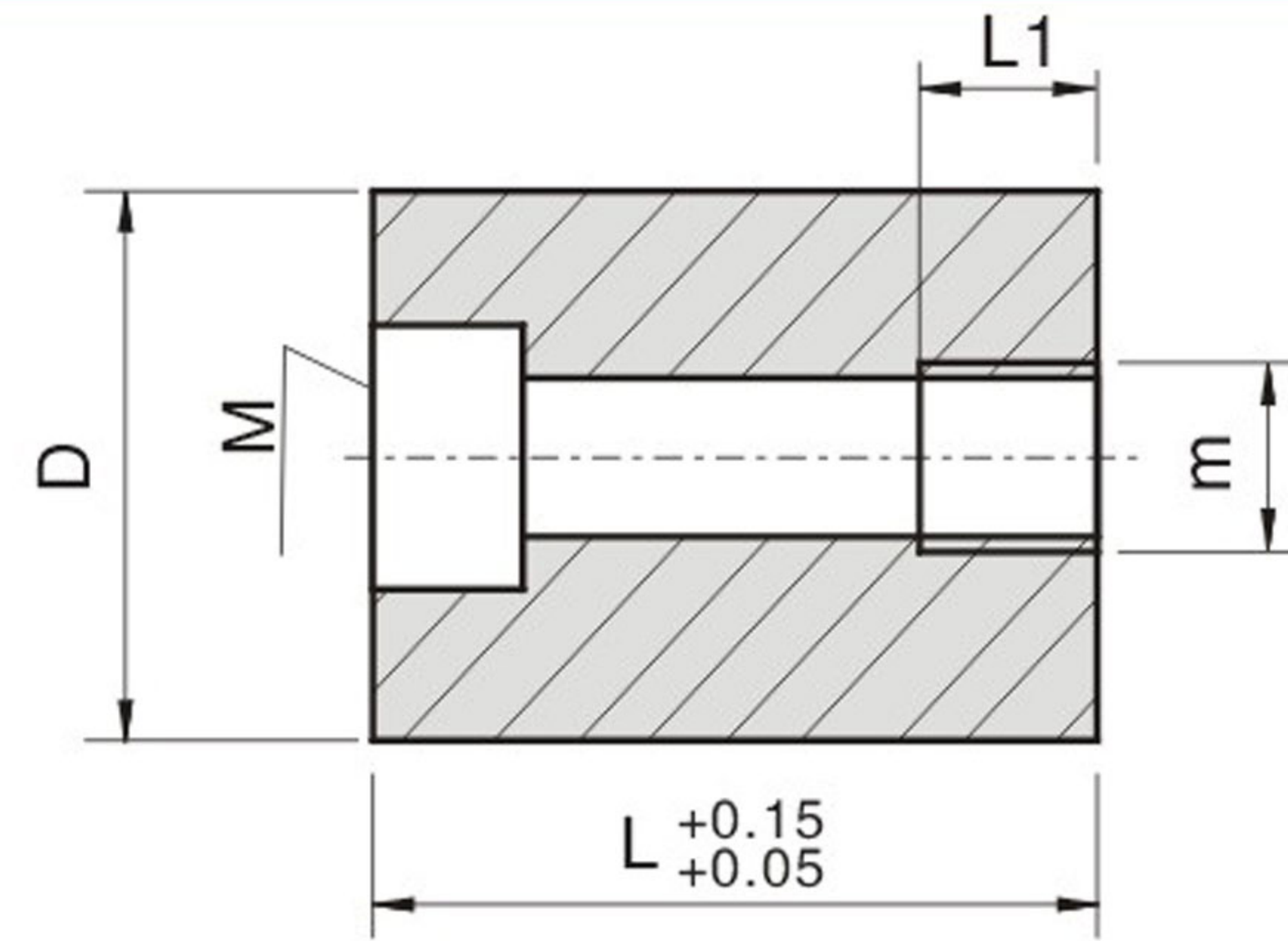

	D						
	32	40	50	60	63	70	80
L1	15	20	20	20	20	25	25
M	M6	M8	M8	M8	M8	M10	M10
n	M8	M10	M10	M10	M10	M12	M12

Type	L	D						
		32	40	50	60	63	70	80
GSH	46	○	○	○				
	56	○	○	○	○	○		
	66	○	○	○	○	○	○	○
	76	○	○	○	○	○	○	○
	86	○	○	○	○	○	○	○
	96	○	○	○	○	○	○	○
	116	○	○	○	○	○	○	○
	136			○	○	○	○	○
	156				○	○	○	○
	176						○	○

Order: GSH - D - L - Q'TY

# GLS

## 限位螺絲 limiting screw

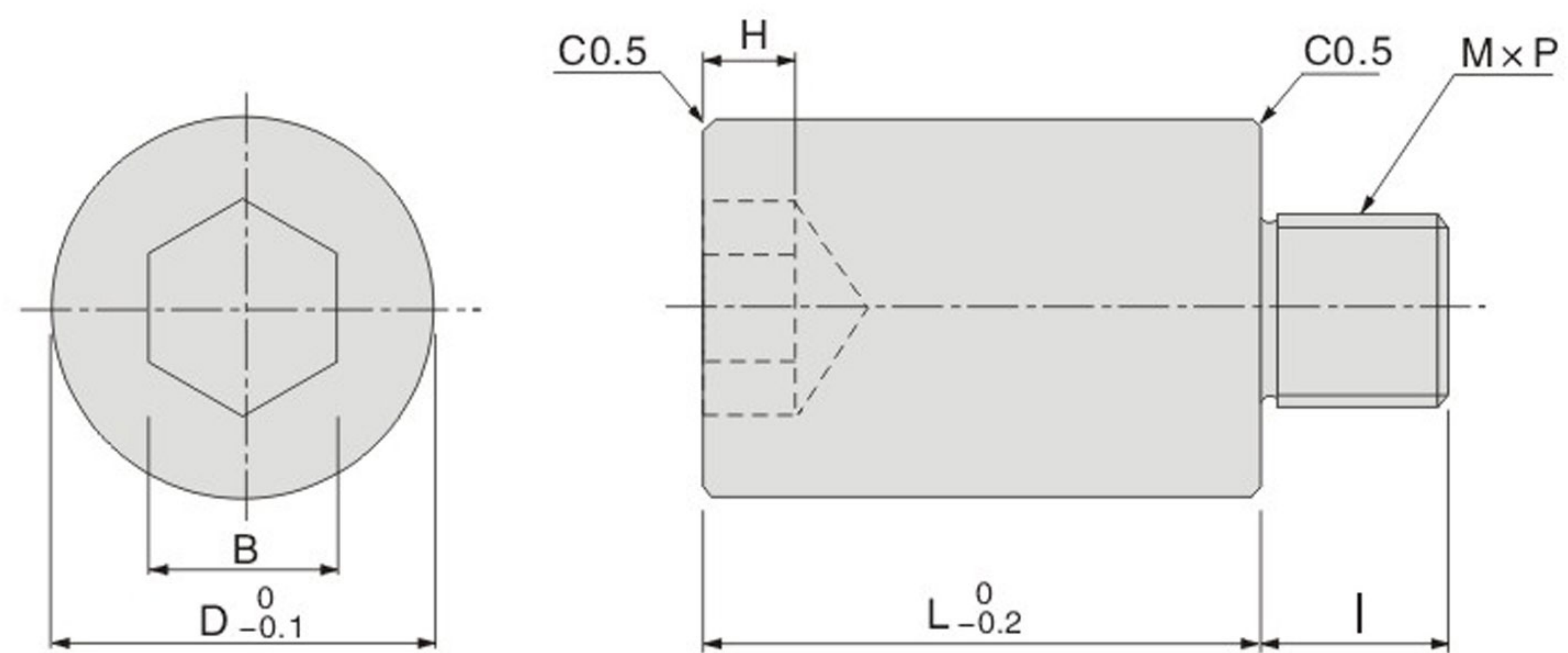
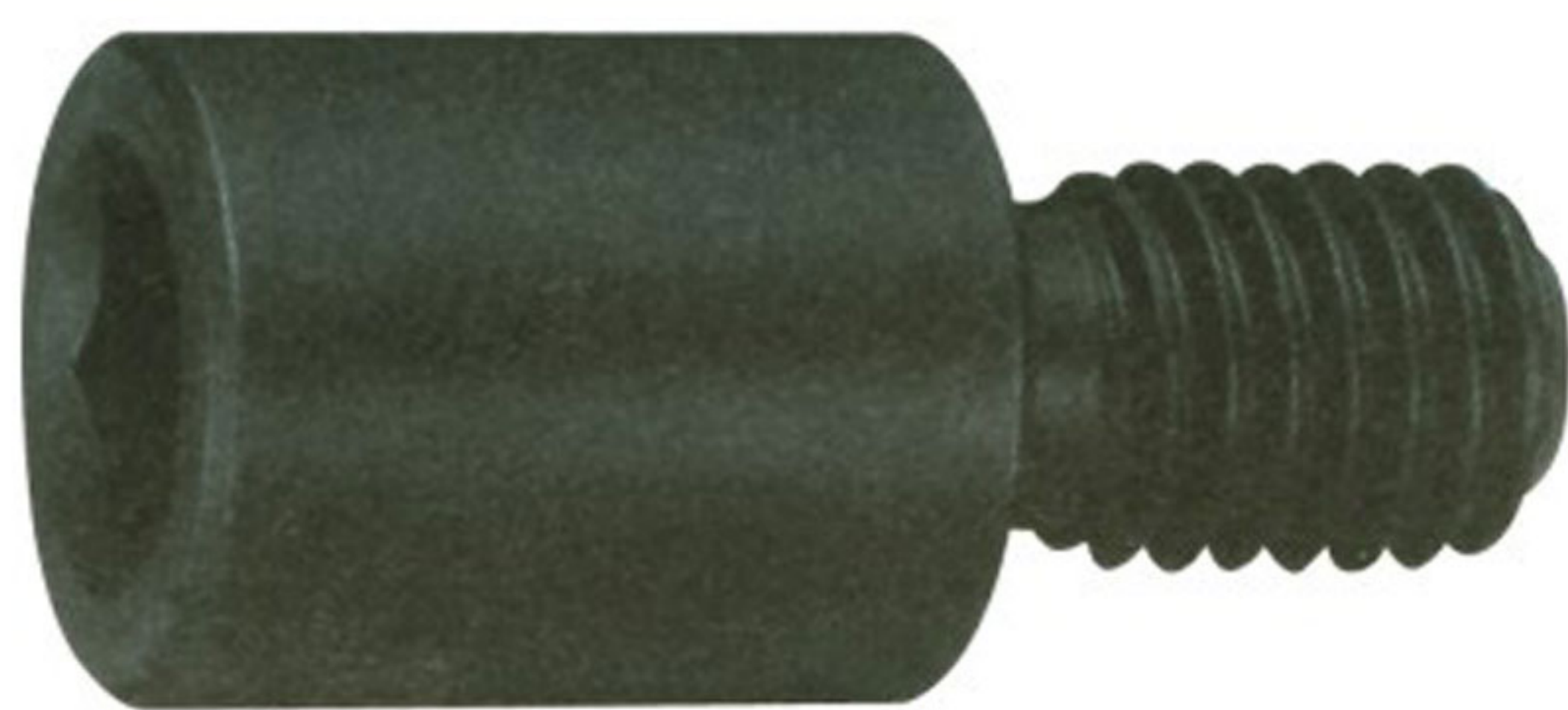

- M** 材質 S45C
- H** 硬度 HRC35° ± 2°
- S** 表面處理 發藍(Fe3O4)

Type No.		L							M×P	B	H	I
Type	D	15	20	25	30	35	40					
GLS	10	15	20	25	30			6×1.0	5	4	10	
	16		20	25	30			10×1.5	8	5	15	
	20		20	25	30	35	40	12×1.75	10	6	18	
	25			30	35	40		16×2.0	14	9	24	

Order: GLS - D - L - Q'TY



# 頂針系列 Extrusion Series

**GPB**

無給油導套 (銅合金) Oil-free Guide Bushings

塑膠模用標準零配件

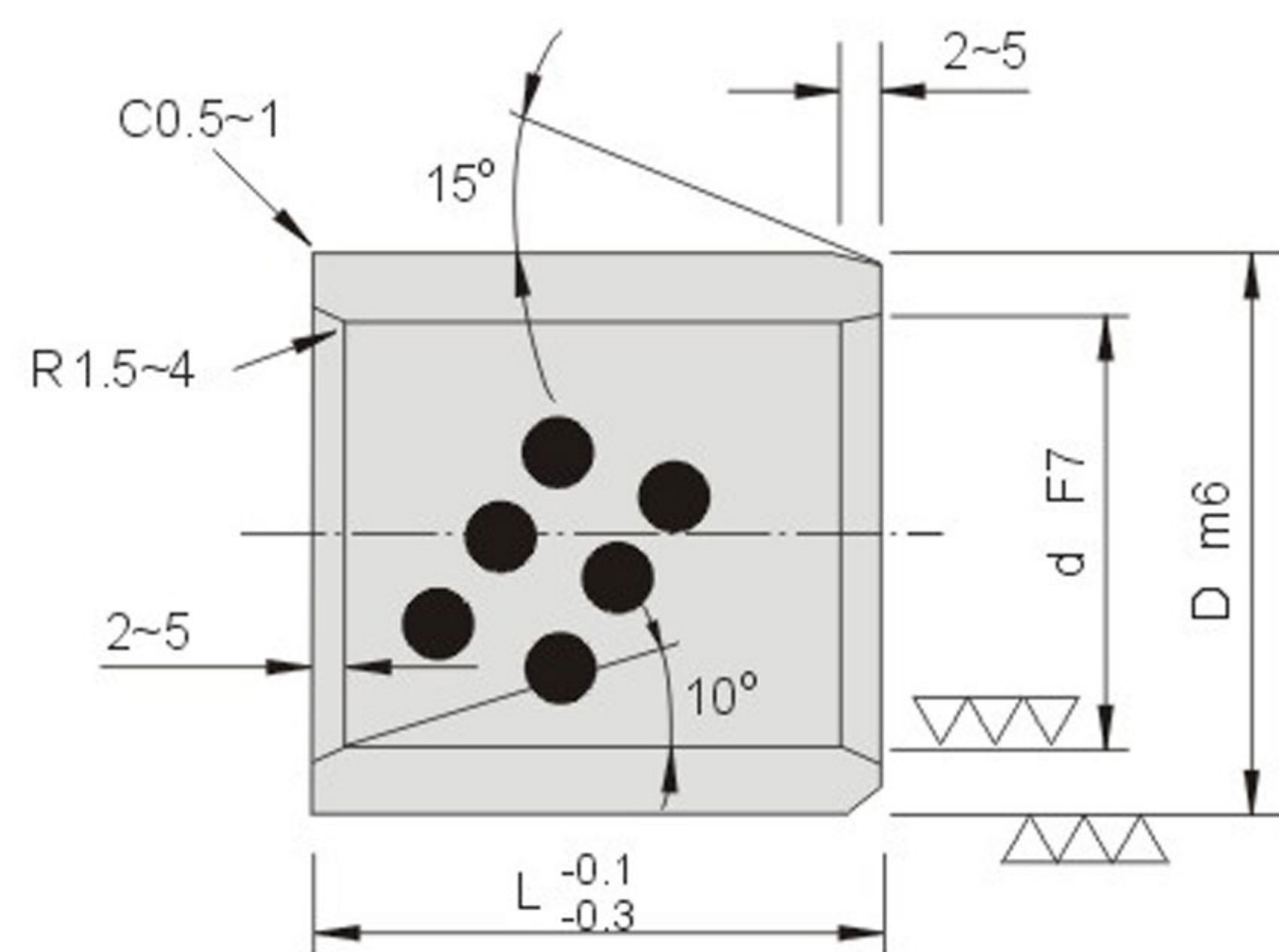

材質: 銅合金  
石墨 (黑鉛)

公制: mm Price:(HKD)

Type	尺寸 (mm)																				適用墊圈					
	內徑		外徑		長度 L -0.1 -0.3																		內徑 d	厚度 T		
	d	公差	D	公差	8	10	12	15	16	20	25	30	35	40	50	60	70	80	90	100	120	130			140	
GPB	8	+0.028 +0.013	12	+0.018 +0.007	○	○	○	○	○	○	○													-	-	
	10	"	14	"	○	○	○	○	○	○	○													10.2	3	
	12	+0.034 +0.016	18	"	○	○	○	○		○	○	○												12.2	3	
	13	"	19	+0.021 +0.008	○	○	○	○		○	○	○													13.2	3
	14	"	20	"	○	○	○	○		○	○	○	○												14.2	3
	15	"	21	"	○	○	○	○		○	○	○	○	○											15.2	3
	16	"	22	"	○	○	○	○	○	○	○	○	○	○											16.2	3
	18	"	24	"	○	○	○	○	○	○	○	○	○	○	○										18.2	3
	20	+0.041 +0.020	28	"	○	○	○	○	○	○	○	○	○	○	○	○									20.2	5
	20	"	30	"	○	○	○	○	○	○	○	○	○	○	○	○									-	-
	25	"	33	+0.025 +0.009				○		○	○	○	○	○	○	○									25.2	5
	25	"	35	"				○		○	○	○	○	○	○	○									25.2	5
	30	"	38	"	○	○	○	○	○	○	○	○	○	○	○	○	○								30.2	5
	30	"	40	"	○	○	○	○	○	○	○	○	○	○	○	○	○								30.2	5
	35	"	44	"	○	○	○	○	○	○	○	○	○	○	○	○	○								35.2	5
	35	"	45	"	○	○	○	○	○	○	○	○	○	○	○	○	○								35.2	5
	40	"	50	"	○	○	○	○	○	○	○	○	○	○	○	○	○	○							40.2	7
	40	"	55	+0.030 +0.011	○	○	○	○	○	○	○	○	○	○	○	○	○	○	○	○	○	○	○	○	40.2	7
	45	"	55	"						○	○	○	○	○	○	○	○	○	○	○	○	○	○		45.2	7
	45	"	56	"						○	○	○	○	○	○	○	○	○	○	○	○	○	○		45.2	7
	45	"	60	"						○	○	○	○	○	○	○	○	○	○	○	○	○	○		45.2	7
	50	"	60	"	○	○	○	○	○	○	○	○	○	○	○	○	○	○	○	○	○	○	○		50.3	8
	50	"	62	"	○	○	○	○	○	○	○	○	○	○	○	○	○	○	○	○	○	○	○		50.3	8
	50	"	65	"	○	○	○	○	○	○	○	○	○	○	○	○	○	○	○	○	○	○	○		-	-
	55	+0.060 +0.030	70	"						○	○	○	○	○	○	○	○	○	○	○	○	○	○		55.3	8
	60	"	74	"	○	○	○	○	○	○	○	○	○	○	○	○	○	○	○	○	○	○	○		60.3	8
	60	"	75	"	○	○	○	○	○	○	○	○	○	○	○	○	○	○	○	○	○	○	○		60.3	8
	63	"	90	"						○	○	○	○	○	○	○	○	○	○	○	○	○	○		-	-
	65	"	80	"						○	○	○	○	○	○	○	○	○	○	○	○	○	○		65.3	8
	70	"	85	+0.035 +0.013	○	○	○	○	○	○	○	○	○	○	○	○	○	○	○	○	○	○	○		70.3	10
70	"	90	"	○	○	○	○	○	○	○	○	○	○	○	○	○	○	○	○	○	○	○		70.3	10	
75	"	90	"						○	○	○	○	○	○	○	○	○	○	○	○	○	○		75.3	10	
75	"	95	"																					75.3	10	
80	"	96	+0.035 +0.013	○	○	○	○	○	○	○	○	○	○	○	○	○	○	○	○	○	○	○		80.3	10	
80	"	100	"	○	○	○	○	○	○	○	○	○	○	○	○	○	○	○	○	○	○	○		80.3	10	
90	+0.071 +0.036	110	"						○	○	○	○	○	○	○	○	○	○	○	○	○	○		90.5	10	
100	"	120	"						○	○	○	○	○	○	○	○	○	○	○	○	○	○		100.5	10	
110	"	130	+0.040 +0.015	○	○	○	○	○	○	○	○	○	○	○	○	○	○	○	○	○	○	○		-	-	
120	"	140	"	○	○	○	○	○	○	○	○	○	○	○	○	○	○	○	○	○	○	○		120.5	10	

Order: GPB - d - D - L - Q'TY

※ 可接受圖面追加工  
(Special product is available)



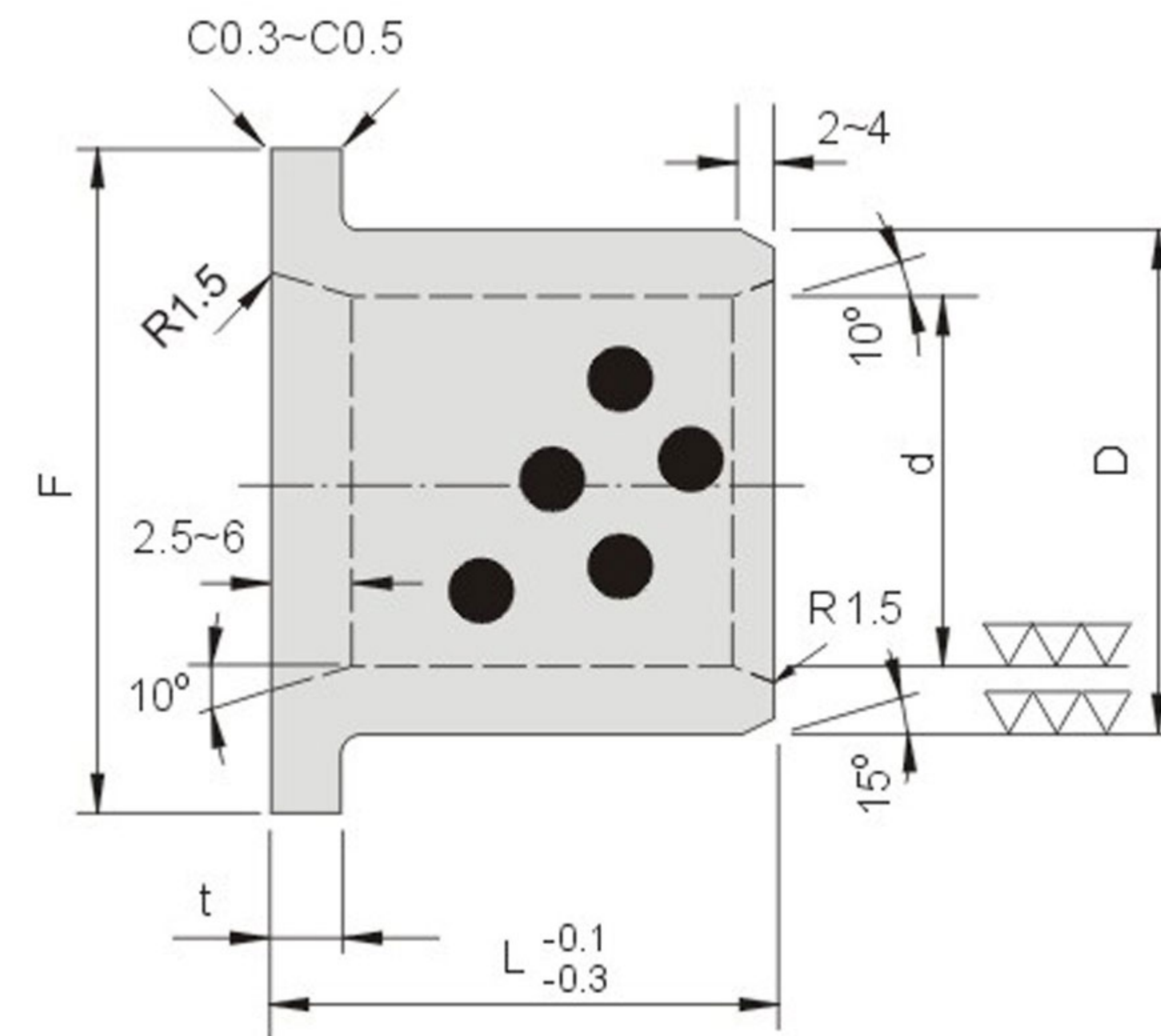

材質: 銅合金  
石墨 (黑鉛)

Price:(HKD)

公制: mm

Type	尺寸 (mm)																				
	內徑		外徑		凸緣		長度 L 公差 $\begin{matrix} -0.1 \\ -0.3 \end{matrix}$														
	d	公差	D	公差	外徑 F	厚度 t	公差	10	12	15	20	25	30	35	40	50	60	70	80	100	
GPF	10	+0.040 +0.025	14	+0.034 +0.023	22	2	0 -0.1	○	○	○	○	○	○								
	12	+0.050 +0.032	18	"	25	3	"	○	○	○	○	○	○								
	13	"	19	+0.041 +0.028	26	"	"	○	○	○	○	○	○								
	14	"	20	"	27	"	"	○	○	○	○	○	○								
	15	"	21	"	28	"	"	○	○	○	○	○	○								
	16	"	22	"	29	"	"	○	○	○	○	○	○	○	○						
	20	+0.061 +0.040	30	"	40	5	"	○	○	○	○	○	○	○	○	○	○	○			
	25	"	35	+0.050 +0.034	45	"	"	○	○	○	○	○	○	○	○	○	○	○	○	○	
	30	"	40	"	50	"	"	○	○	○	○	○	○	○	○	○	○	○	○	○	○
	35	"	40	"	60	"	"				○	○	○	○	○	○	○	○	○	○	○
	40	"	50	"	65	"	"				○	○	○	○	○	○	○	○	○	○	○
	45	"	55	+0.060 +0.041	70	"	"		○	○	○	○	○	○	○	○	○	○	○	○	○
	50	"	60	"	75	"	"		○	○	○	○	○	○	○	○	○	○	○	○	○
	55	+0.090 +0.060	65	"	80	"	"		○	○	○	○	○	○	○	○	○	○	○	○	○
	60	"	75	+0.062 +0.043	90	7.5	"				○	○	○	○	○	○	○	○	○	○	○
	63	"	75	"	85	"	"					○	○	○	○	○	○	○	○	○	○
	70	"	85	+0.073 +0.051	105	"	"						○	○	○	○	○	○	○	○	○
	75	"	90	"	110	"	"					○	○	○	○	○	○	○	○	○	○
	80	"	100	"	120	10	"					○	○	○	○	○	○	○	○	○	○
	90	+0.107 +0.072	110	+0.076 +0.054	130	"	"					○	○	○	○	○	○	○	○	○	○
100	"	120	"	150	"	"						○	○	○	○	○	○	○	○	○	
120	"	140	+0.088 +0.063	170	"	"							○	○	○	○	○	○	○	○	



Order: GPF - d - D - L - Q'TY

※ 可接受圖面追加工  
(Special product is available)



# 頂針系列 Extrusion Series

**GPP**

無給油滑動板 Self Lubricating Plate

塑膠模用標準零配件

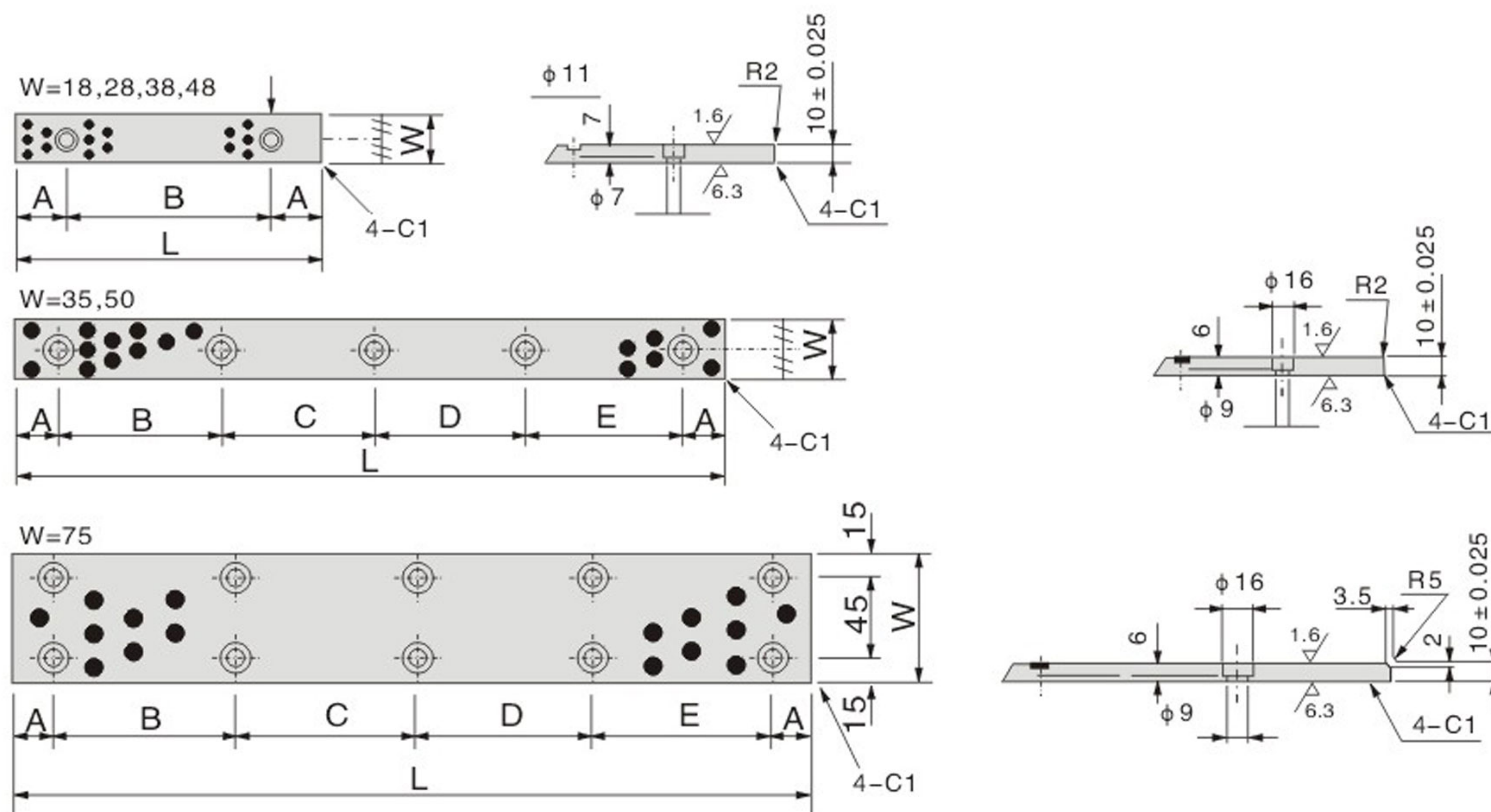
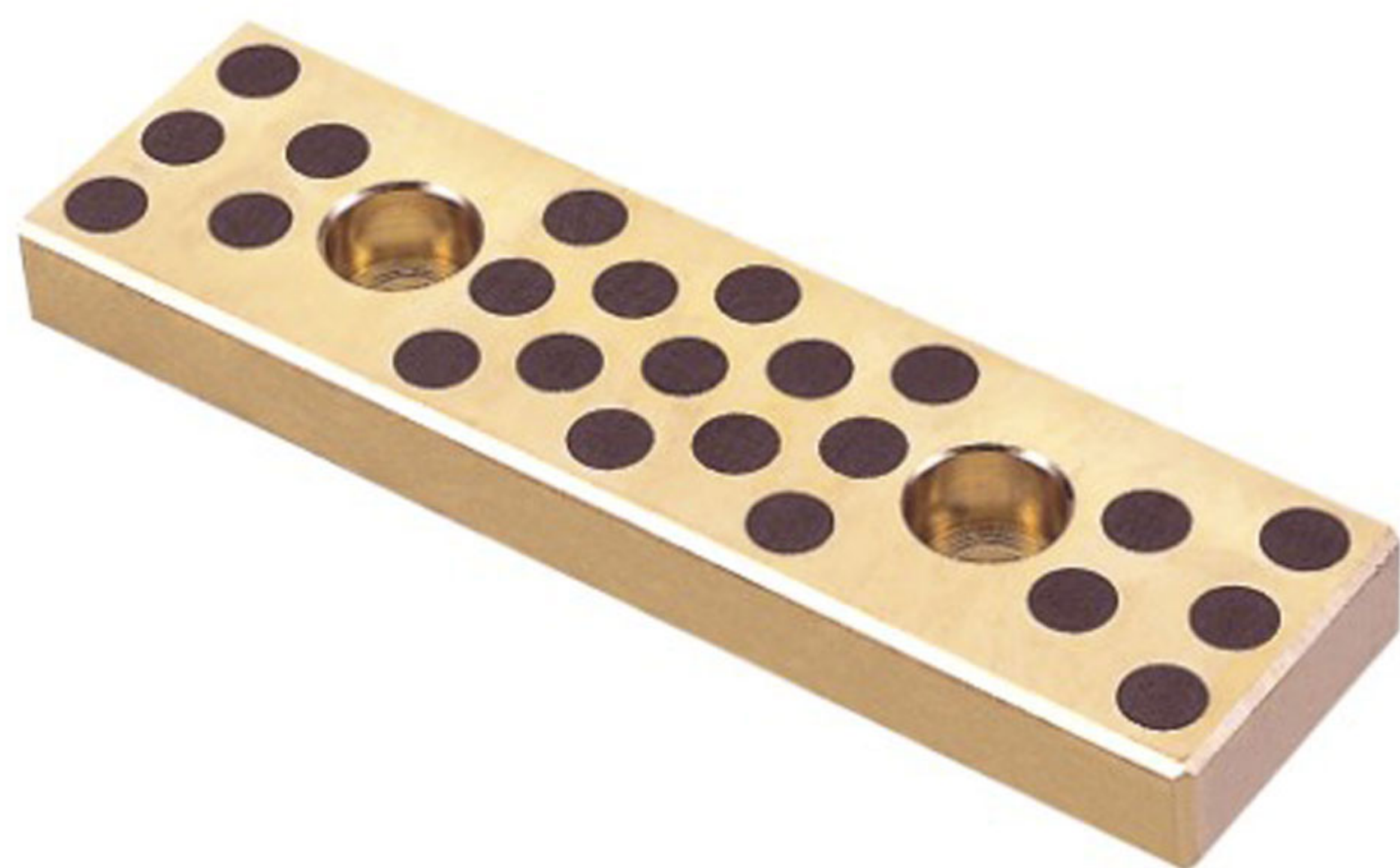

材質: 銅合金  
石墨(黑鉛)

Type No.	W	L	A	B	C	D	E	平頭螺栓 Flat Head Screw	孔數 No. of Holes			
<b>GPP</b>	18	75	15	45				M6	2			
		100		50								
		125	25	75								
		150		100								
	28	75	15	45						M8	3	
		100		50								
		125	25	75								
		150		100								
	35	100	20		60				M8			4
		150		55	55							
		200		55	50	55						
		250		70	70	70						
		300		65	65	65	65					
	38	75	15	45				M6	2			
		100		50								
		125	25	75								
		150		100								
	48	75	15	45						M8	3	
		100		50								
		125	25	75								
		150		100								
	50	100	20		60				M8			4
		150		55	55							
		200		55	50	55						
250		70		70	70							
300		65		65	65	65						
75	400	20		90	90	90		M8	5			
	150		110									
	200		80	80								
	250		105	105								
	300		85	85	85							
	400		120	120	120							
500	115	115	115	115								

Order: GPP - W - L - Q'TY

※ 可接受圖面追加工  
(Special product is available)



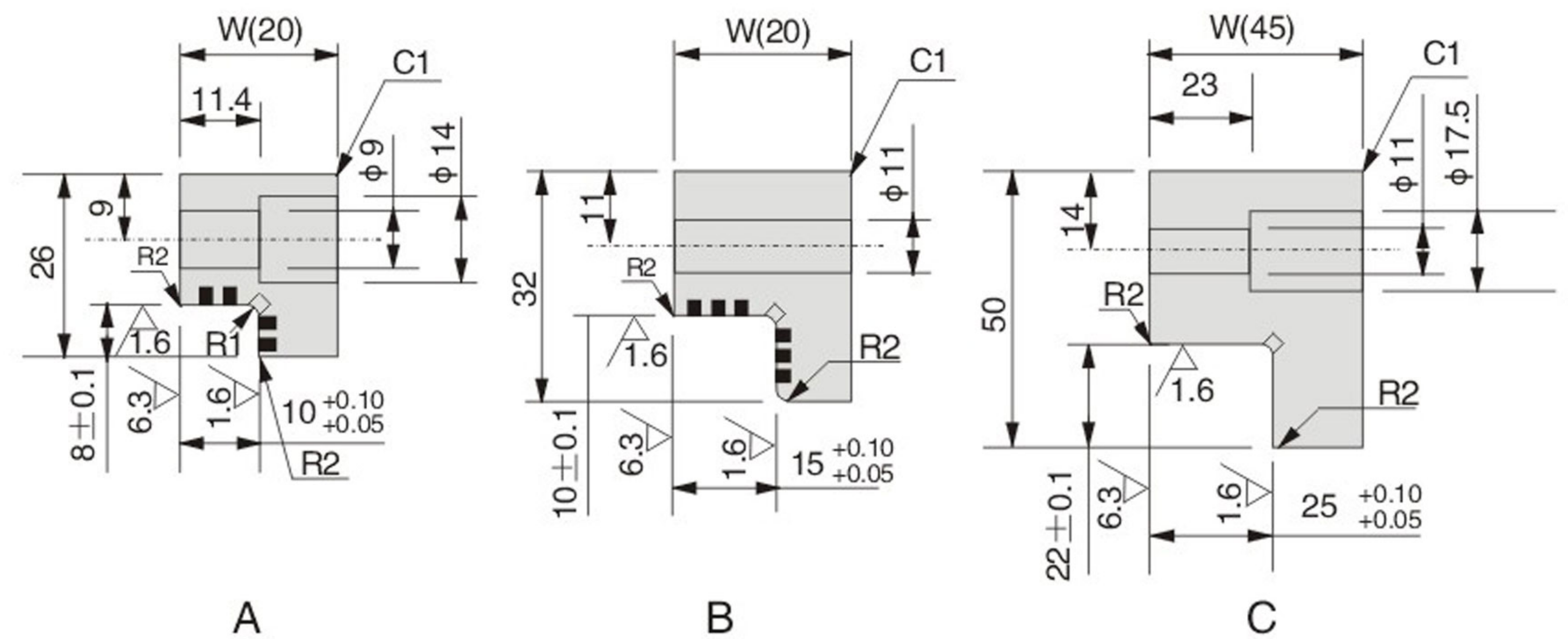
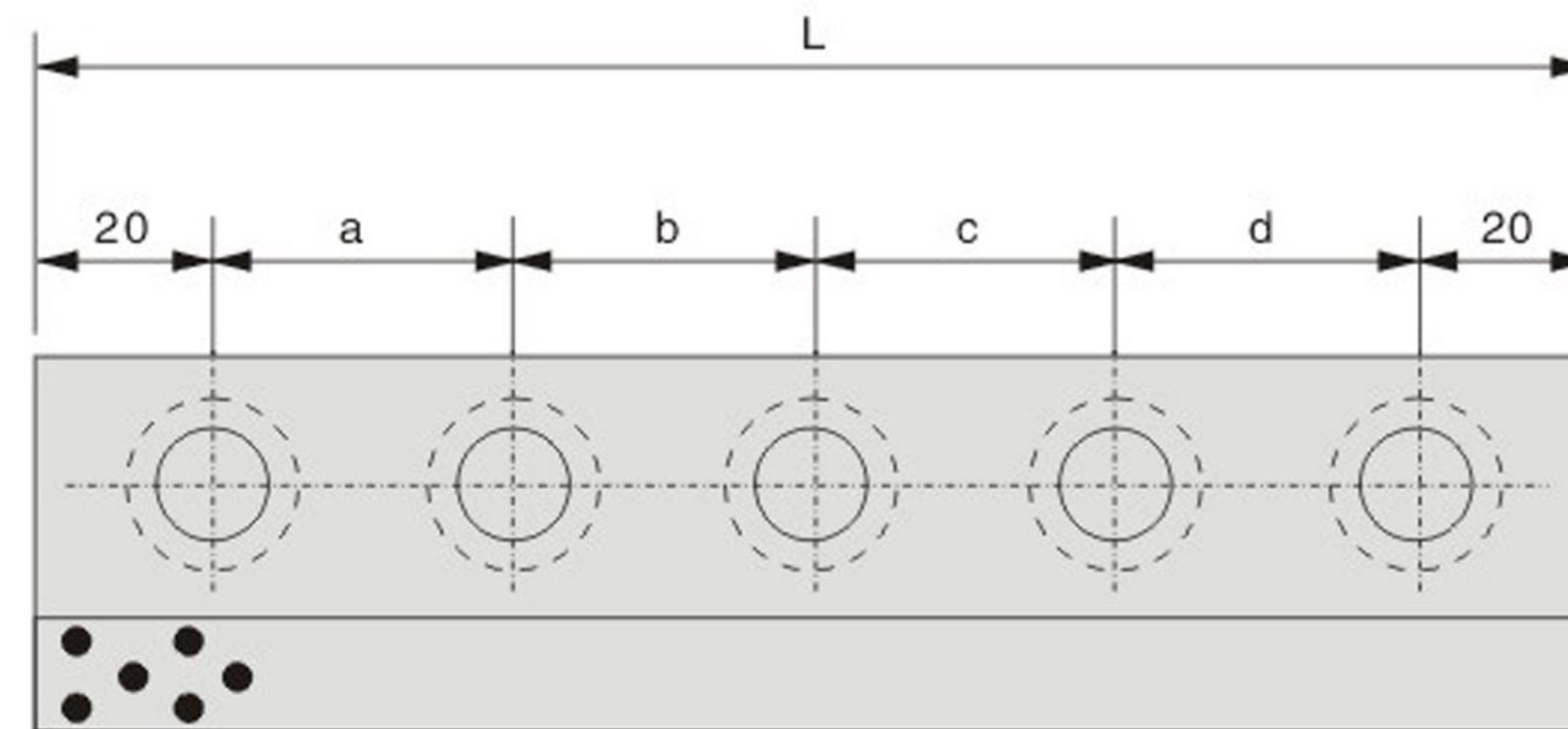

M 材質: 銅合金  
 石墨(黑鉛)

Type No.	W	L	(螺钉) Bolt					图形 Sketch	
			a		c				
GPH20X100	20	100	60				M8	2	A
GPH20X150		150	55	55				3	
GPH20X200		200	55	50	55			4	
GPH30X100	30	100	60				M10	2	B
GPH30X150		150	55	55				3	
GPH30X200		200	55	50	55			4	
GPH30X250		250	70	70	70			4	
GPH45X200	45	200	55	50	55		M10	4	C
GPH45X250		250	70	70	70			4	
GPH45X300		300	65	65	65	65		5	
GPH45X350		350	80	75	75	80		5	

📄 Order: GPH20X100 - Q'TY



※ 可接受圖面追加工  
 (Special product is available)





**精展精密科技股份有限公司(總公司)**  
**GIN TECH PRECISION CO., LTD.**

238001台灣新北市樹林區保安街一段341巷7號

Address: No 7, Lane 341, Sec. 1, Bau An Street, Shulin Dist.,  
New Taipei City, 238001, Taiwan

TEL: 886-2-2681-8596 (Rep.)

Email: [Sales@ginchan.com.tw](mailto:Sales@ginchan.com.tw)

FAX: 886-2-2681-8516

Web: [www.gin-chan.com](http://www.gin-chan.com)

**東莞美商精展機械五金有限公司**  
**東莞市精展機械五金有限公司**  
**GIN CHAN MACHINERY & HARDWARE CO., LTD.(DONGGUAN)**

廣東省東莞市大朗鎮石廈村金沙崗二路27號

Address: No 27, Jinshagang 2nd Road, Shixia Village,  
Dalang Town, Dongguan, Guandong, P.R. China

TEL: 86-769-8318-5858 (Rep.)

Email: [Sales@ginchan.com.cn](mailto:Sales@ginchan.com.cn)

FAX: 86-769-8318-5838/8313-5003

Web: [www.ginchan.com.cn](http://www.ginchan.com.cn)



YouTube



微信扫一扫