

鑽石工具系列

Diamond File Series

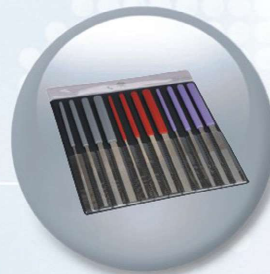

纖維油石、EDM油石
Fiber Stones/EDM Stones



鑽石銼刀
Diamond Files



鑽石修刀
Diamond Dressers



鑽石磨棒
Diamond Burrs



鎢鋼滾磨刀
Solid Carbide



棕刷、帶柄砂輪
Brush/Grinding Pins



電動研磨機
Electric Rotary



氣動工具
Pneumatic Tool





JR F02
水晶纖維油石
CRYSTAL FIBER STONES



鑽石銼刀系列 F12
DIAMOND FILE SERIES



鎢鋼滾磨刀 F25
SOLID CARBIDE



CS F03
犀利盾超級纖維油石
CERAMIC FIBER STONES



DDC F17
圓錐修刀
CONED DIAMOND DRESSERS



DPS F28
鑽石油石
DIAMOND POLISHING STONES



JR F05
迷你纖維油石
MINIATURE FIBER STONES



DDP F17
角錐修刀
PYRAMID DRESSERS



AB F29
棕刷系列
BRUSHES

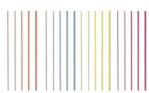

JM S F06
迷你犀利盾纖維油石
MINI CERAMIC FIBER STONES



DDM F18
多石修刀
MULTI POINT DIAMOND DRESSERS



ABP F30
氧化鋁帶柄砂輪
ALUMINUM OXIDE GRINDING PINS



CDS F07
鑽石纖維油石
CERAMIC DIAMOND STONES



DDS F18
單石修刀
SINGLE DIAMOND DRESSERS



DPC F31
鑽石砂布
DIAMOND FOIL
SP-FLO
德國超微粒光學拋光布
MICRO-POLIERLEINEN
(MADE IN GERMANY)



XH F08
油石夾柄
POLISHING STONE HOLDERS



DDI F19
組合修刀
IMPREGNATED DIAMOND DRESSERS



ABL F32
牛皮彈性帶柄砂輪
COW LEATHER ELASTIC GRINDING PINS



GS F09
GS油石(Made in Japan)
GS EDM STONES



DDH F19
手持式結合修刀
HAND DIAMOND DRESSERS



ABR F32
海綿彈性帶柄砂輪
SPONGE ELASTIC GRINDING PINS



GS F10
油石(Made in Japan)



BDS/BBS F20
鑽石磨棒
DIAMOND BURRS



ABR-CM F33
日本制大和海綿輪
DAIWA RABIN(MADE IN JAPAN)



FLASH600 F11
油石研磨液
(Made in Japan)
FLASH 600 STONING OIL

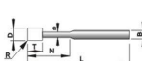

MMD/MMB F23
鑽石及氮化硼(CBN)
DIAMOND & CBN MANDRELS

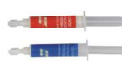

CMP/KMP F35
GS鑽石膏
GS DIAMOND COMPOUND

 <p>GLV500 F36 50,000轉電動研磨機 50,000RPM ELECTRIC ROTARY</p>	 <p>MAG-122N F40 內孔研磨機 Inner Hole Air Grinder (90°)</p>	 <p>AIR-A965 F42 內孔研磨機 Inner Hole Air Griner (45°)</p>
 <p>GLV450 F37 45,000轉電動研磨機 45,000RPM ELECTRIC ROTARY</p>	 <p>AIR-917或913 F41 超高速來回研磨機 Ultrahigh Speed Grinding Machine</p>	 <p>AIR-A967 F42 內孔研磨機 Inner Hole Air Griner (90°)</p>
 <p>GLV350 F37 35,000轉電動研磨機 35,000RPM ELECTRIC ROTARY</p>	 <p>AIR-947或943 F41 輕渦輪長時間作業用 Turbine Long Time Operation</p>	 <p>AIR-A971 F43 0.3馬力強力研磨機 0.3 HP Air Grinder</p>
 <p>GEX58 F38 雙功能實用型超音波研磨機 DUAL-FUNCTION PRACTICAL ULTRASONIC POLISHER</p>	 <p>AIR-951 F41 輕量高速筆刻機 High Speed Air Grinder</p>	 <p>AIR-A972 F43 平面左右研磨機 Swing Stroke Air Grinder</p>
 <p>TLL-07 F39 往複式氣動超音波機 Reciprocating Ultrasonic Air Grinder</p>  <p>TLL-03 F39 往複式氣動超音波 Reciprocating Ultrasonic Air Grinder</p>	 <p>AIR-953 F41 雙接型高速筆刻機 High Speed Air Grinder</p>	 <p>AIR-A973 F43 砂輪研磨機 Grinding Wheel Grinder</p>
 <p>TLL-1.2 F39 往複式氣動超音波 Reciprocating Ultrasonic Air Grinder</p>  <p>TLL-0.15 F39 往複式氣動超音波 Reciprocating Ultrasonic Air Grinder</p>	 <p>AIR-954 F41 高速筆刻機 High Speed Air Grinder</p>	 <p>AIR-A974 F43 左右研磨機 Swing Air Lapper</p>
 <p>FX-A3.0 F39 高速筆刻機 High Speed Straight Air Grinder</p>	 <p>AIR-952 F42 高速型氣動研磨機 High Speed Air Grinder</p>	 <p>60031-36 BHF微調精密鑽頭 Small Diameter Fine Boring Head</p>
 <p>MSG-3BSN F40 精密型刻磨機 High Speed Straight Air Grinder</p>  <p>MAG-123N F40 平面研磨機 Surface Air Grinder (120°)</p>	 <p>AIR-965 F42 平面研磨機 45° Angle Air Grinder</p>	 <p>60050 BHF微調精密鑽頭 Small Diameter Fine Boring Head</p>
 <p>MAG-093N F40 平面研磨機 Surface Air Grinder (90°)</p>  <p>MAG-121N F40 內孔研磨機 Inner Hole Air Grinder (120°)</p>	 <p>AIR-967 F42 平面研磨機 Surface Air Grinder (90°)</p>	 <p>60010 BHW小徑精鑽頭+刀柄 Small Diameter Fine Boring Head+Shank</p>

鑽石工具系列 Diamond File Series

JR

水晶纖維油石 Crystal Fiber Stones

Cristone[®] The Crystal Fiber Stones

Cristone水晶纖維油石以強韌的水晶陶瓷纖維所制成，強度比一般的纖維油石提高一倍，適合用於去除放電加工后(EDM)所產生的粗糙表面。高單位纖維含量以及整齊銳利的水晶纖維端面讓切削速度大幅度提升，使您的工作更有效率。

Cristone stands for Crystal Stone made from using the highest quality, chemically produced crystal fibers. The crystalline structure of the crystal fibers Offers high polishing efficiency and incredible bending strength. These are the perfect stones for detail polishing. Extremely strong for tight ribs and slots, excellent for EDM removal.

高强度

抗折强度1300MPa

High Strength

The highest bending strength 1300MPa

高研磨力

研磨速度約提升2倍

(500mg 研磨速度縮短50%，#400使用實績)

High Polishing

2 times polishing efficiency of Ceramic stones!

(Can save 50% in EDM scale removal times)

平滑的切削面

纖維構成面平整，研磨效果更佳！

(Ra=0.4 μ 研磨速度縮短50%，#400使用實績)

High Surface

Optimal crystalline structure for polishing

(can save 50% cutting time to reach Ra=0.4 μ)

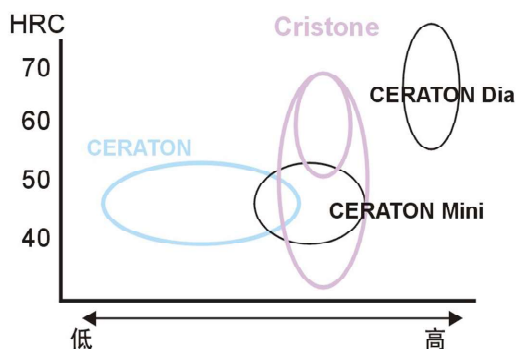

犀利盾系列纖維油石

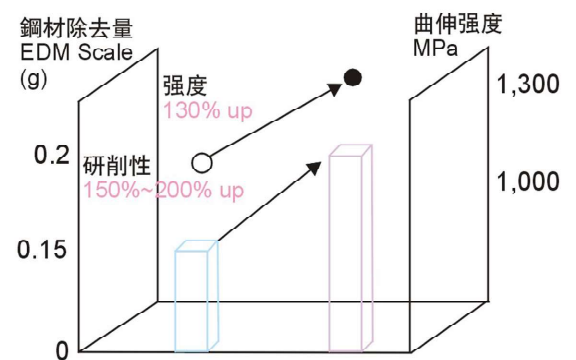

水晶系列纖維油石

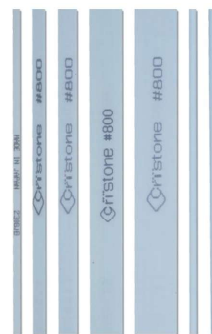
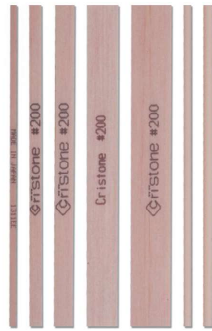
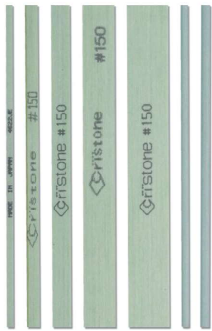

鑽石銼刀系列



粒度編號及訂購代號 Grit Size & Order No.

		#150	#200	#400	#600	#800	#1000
		Green	Pink	Violet	Orange	Blue	White
	TxWxL (ØDxL)mm						
	1x2x100	JRG-0102100	JRP-0102100	JRV-0102100	JRO-0102100	JRB-0102100	JRW-0102100
	1x4x100	JRG-0104100	JRP-0104100	JRV-0104100	JRO-0104100	JRB-0104100	JRW-0104100
	1x6x100	JRG-0106100	JRP-0106100	JRV-0106100	JRO-0106100	JRB-0106100	JRW-0106100
	1x10x100	JRG-0110100	JRP-0110100	JRV-0110100	JRO-0110100	JRB-0110100	JRW-0110100
	1x13x100	JRG-0113100	JRP-0113100	JRV-0113100	JRO-0113100	JRB-0113100	JRW-0113100
	Ø3x100	JRG-03100	JRP-03100	JRV-03100	JRO-03100	JRB-03100	JRW-03100
	Ø2.35x100	JRG-0235100	JRP-0235100	JRV-0235100	JRO-0235100	JRB-0235100	JRW-0235100

鑽石工具系列 Diamond File Series

CS

犀利盾超級纖維油石 Ceramic Fiber Stones

CERATON[®] The Ceramic Fiber Stones

犀利盾纖維油石以陶瓷纖維結合強韌樹脂所制成，比起傳統油石更具高強度的切削力及切削壽命。手持研磨效果優于傳統油石且纖維油石本身耐高熱、富高彈性及不易塞穴的特性。適合使用于電動超音波研磨機、電動或氣動旋轉工具及氣動銼磨機等各類長時間連續加工機具。

CERATON is made from ceramic fibers bonded in thermosetting resin, exhibits superior strength compared by normal abrasive stones.

Long life and no clogging is suitable for all kinds of equipments like ultrasonic machines, high speed rotaries, Air Lappers & Air Grinders and also good by hand polishing.

粒度	使用建議
Grit size	Application
#180 #250 #280	模具放電加工后之硬化表層去除及機械切削粗糙刀痕之去除 To remove the rough machining surface or hard EDM scale of tool and die steels.
#360 #400 #500	細致加工痕迹之去除及一般拋磨 General lapping of finer surface scratch line of tool & die steels.
#700 #1000 #1200	精細研磨或鏡面處理前之拋光 Fine polishing & finishing.
Ø3.00mm圓柱/Round	可搭配刻磨機當成研磨棒使用(長度勿超過50mm長), 亦或將之磨尖用于細致角落或窄縫處之研磨 It can used like grinding point(max, length 50mm), or by sharpening it for detail lapping

我們建議使油石端面和工件夾角呈現30°~40°的方式研磨以得到最佳的切削性

In order to reach the best performance, we recommend that the stone should be hold up-right making an angle of approx. 30°~40° to the work piece.

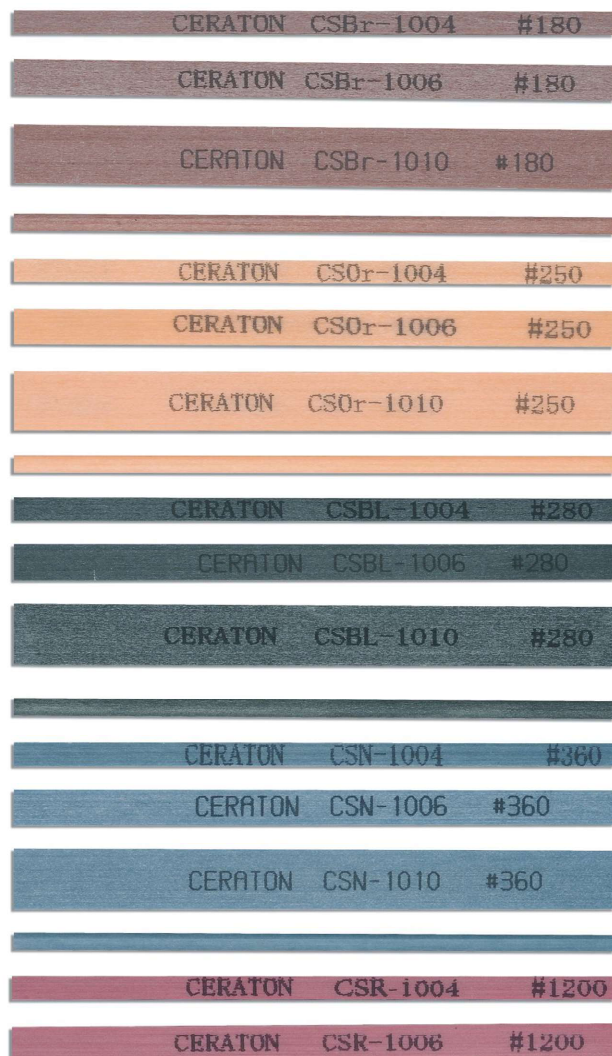

粒度編號及訂購代號 Grit Size & Order No.

	#180	#250	#280	#360	#400	#500	#700	#1000	#1200
	Brown	Orange	Black	Navy Blue	Blue	Green	Yellow	Pink	Red
TxWxL (∅DxL)mm									
1x4x100	CSC-1004	CSO-1004	CSD-1004	CSN-1004	CSB-1004	CSG-1004	CSY-1004	CSP-1004	CSR-1004
1x6x100	CSC-1006	CSO-1006	CSD-1006	CSN-1006	CSB-1006	CSG-1006	CSY-1006	CSP-1006	CSR-1006
1x10x100	CSC-1010	CSO-1010	CSD-1010	CSN-1010	CSB-1010	CSG-1010	CSY-1010	CSP-1010	CSR-1010
∅2.35x100	CGC-235	CGO-235	CGD-235	CGN-235	CGB-235	CGG-235	CGY-235	CGP-235	CGR-235
∅3x100	CGC-30	CGO-30	CGD-30	CGN-30	CGB-30	CGG-30	CGY-30	CGP-30	CGR-30

鑽石工具系列 Diamond File Series

JR

迷你纖維油石 Miniature Fiber Stones

Cristone® The Mini Crystal Fiber Stones

水晶迷你纖維油石及犀利盾迷你纖維油石裁切成0.3x0.3mm~1x2mm等各式微小尺寸，主要用于凹縫、小溝槽等細部研磨，一般傳統油石或紅寶石油石如果裁成相同大小的尺寸時會產生容易斷裂的情形，但水晶迷你纖維油石及犀利盾迷你纖維油石具高強度的韌性是用于解決細部加工首選的研磨工具。

Mini Crystal Fiber Stone are cut by crystal fiber stone and Mini Ceramic Fiber Stone are cut by ceramic fiber stone.

Each size from 0.3x0.3mm~1x2mm. Ideal for various mold and dies detail lapping.

Traditional oil stone and ruby stones in such a small sizes are very easy to break, while mini ceramic stone provide high strength and high elasticity. Due to its hard to break, they resolve the problem of using these stones.

用途

適合于各類模具一般研磨或精加工使用尤其針對細部雕刻、溝縫、R角等複雜表面等的研磨。此外對於小型零件的細部研磨，水晶迷你纖維油石及犀利盾迷你纖維油石是您完美的選擇。

It is good for all type of molds and dies fine and super fine finishing. Especially for engraving parts, slight ribs, R ribs, corners, complicated area and details.

Besides, all other tool parts that needs details lapping. Our Mini crystal fiber stone and Mini ceramic fiber stone will be the wonderful tools.

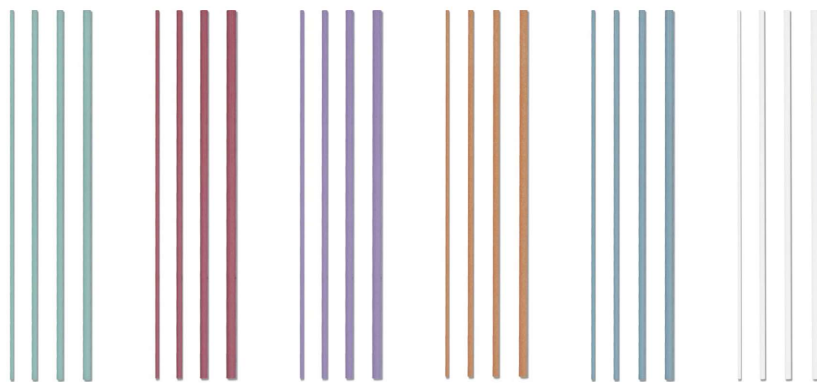

粒度編號及訂購代號 Grit Size & Order No.

	#150	#200	#400	#600	#800	#1000	油石夾柄
	Green	Pink	Violet	Orange	Blue	White	Holder
TxWxL (ØDxL)mm							
0.3x0.3x100	JR150-0303100	JR200-0303100	JR400-0303100	JR600-0303100	JR800-0303100	JR1000-0303100	XH-005
0.5x0.5x100	JR150-0505100	JR200-0505100	JR400-0505100	JR600-0505100	JR800-0505100	JR1000-0505100	XH-007
0.7x0.7x100	JR150-0707100	JR200-0707100	JR400-0707100	JR600-0707100	JR800-0707100	JR1000-0707100	XH-009
0.9x0.9x100	JR150-0909100	JR200-0909100	JR400-0909100	JR600-0909100	JR800-0909100	JR1000-0909100	XH-013

單一尺寸，粒度最小訂購量10支/盒 Minimum order 10pcs/box per grit size.

迷你纖維油石是將纖維油石切成細微尺寸，從0.3x0.3mm到1x2mm。專門使用于各種模具之細微部位或是其它類似之加工，由于陶瓷纖維具有高抗折強度，可解決一般油石易斷之困擾。

迷你纖維油石可適用於各種模具之研磨及各種零件之精細拋光，尤其是雕刻部位之加工、微小肋部、模具角部精細拋磨及各種細微或複雜部位之加工。

Applications

It is excellent stone for EDM removal and is suitable for use on all type of molds and dies, fine and super fine finishing. Especially for engraving parts, slight ribs, radius ribs, corners, complicated area and details.

Besides, all other tool parts that need details lapping, Our Mini Ceramic Fiber Stone will be the wonderful tools.

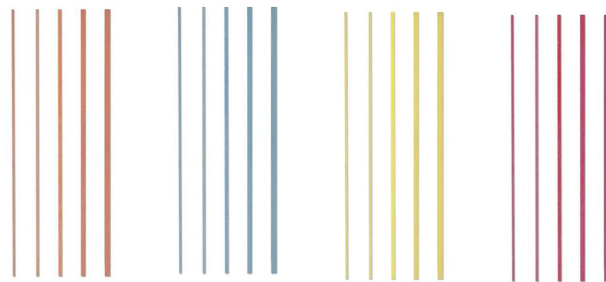

CERATON® The Mini Ceramic Fiber Stones

粒度編號及訂購代號 Grit Size & Order No.

	#250	#400	#700	#1200	Holder
	Orange	Blue	Yellow	Red	油石夾柄
TxWxL (ØDxL)mm					
0.3x0.3x50	JMOS-035	JMBS-035	JMYS-035	JMRS-035	XH-005
0.5x0.5x50	JMOS-055	JMBS-055	JMYS-055	JMRS-055	XH-007
0.7x0.7x50	JMOS-075	JMBS-075	JMYS-075	JMRS-075	XH-009
0.9x0.9x50	JMOS-095	JMBS-095	JMYS-095	JMRS-095	XH-013
1.0x2.0x100	JMOS-121	JMBS-121	JMYS-121	JMRS-121	XH-200
Ø0.9x50	JMOG-105	JMBG-105	JMYG-105	JMRG-105	XH-009
Ø2.0x100	JMOG-201	JMBG-201	JMYG-201	JMRG-201	XH-200

鑽石工具系列 Diamond File Series

CDS

鑽石纖維油石 Ceramic Diamond Stones

一般的纖維油石的切削性來自于油石的端面，但鑽石纖維油石的各部位像是平面、側邊或先端等皆可以使用。一般傳統油石無法加工如超硬度模具等特殊材質的模具，但鑽石纖維油石無此限制。

鑽石纖維油石可用于各類的加工如：EDM放電后的表面研磨、鎢鋼模具的拋光、陶瓷加工研磨以及玻璃表面的研磨等。

The ordinary ceramic fiber stone is efficient only to lap its end side or edge, while the ceramic diamond stone works well with any sides.

Materials those are difficult to be ground by ordinary ceramic stone, now the ceramic diamond stone can provide a much better cut.

Ceramic diamond stone is idea for lapping all kind of harden steels, EDM surface, tungsten carbide, ceramics and glasses efficiently.

CERATON® The Ceramic Diamond Stones

以獨家技術結合陶瓷纖維及鑽石研磨顆粒再搭配強韌的樹脂所制成此款鑽石纖維油石。加入鑽石研磨粉后除了大幅的提升纖維油石的切削性外，對於硬度較高的工件更是游刃有余并同時縮短了加工的時程。

Ceramic diamond stones are made of diamond abrasives and ceramic fibers bonded together with thermosetting resin.

The combination of diamond and ceramic fibers creates the outstanding cutting performance. Ceramic diamond stone is a perfect lapping tool.

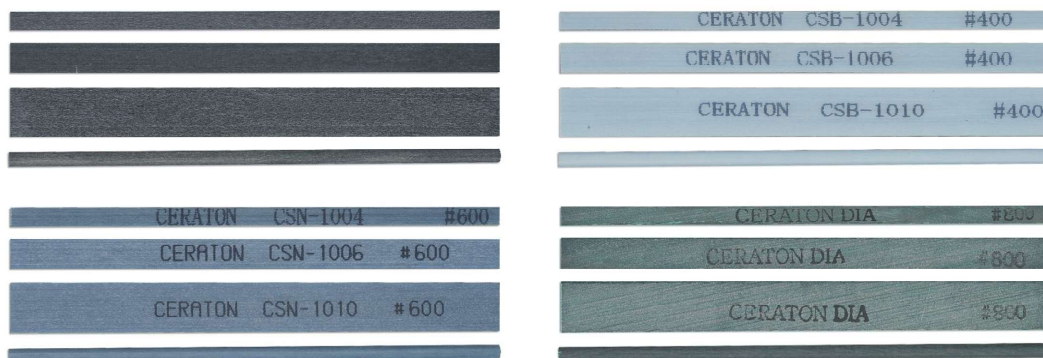

粒度編號及訂購代號 Grit Size & Order No.

	#200	#400	#600	#800
	Black	Gray	Moss Green	Green
TxWxL (ØDxL)mm	●	●	●	●
1x4x100	CDS1004-200	CDS1004-400	CDS1004-600	CDS1004-800
1x6x100	CDS1006-200	CDS1006-400	CDS1006-600	CDS1006-800
1x10x100	CDS1010-200	CDS1010-400	CDS1010-600	CDS1010-800
Ø 3x100	CDS30-200	CDS30-400	CDS30-600	CDS30-800

對於特殊含鐵元素材質的工件，我們另外可提供CBN磨料的纖維油石。詳細內容請洽詢本公司。

In some special applications, ceramic CBN stones are also available.

Depend on your request. Other size and grits are also available, Please ask our salespersons for details.

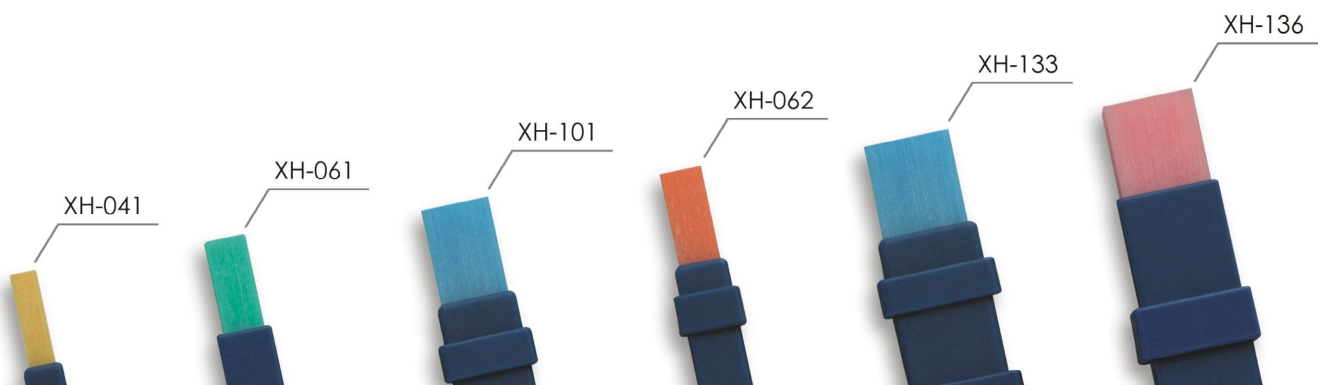

訂購編號	可夾持尺寸		運用
Order No.	Holding Capacity		Applications
XH-041	平形/FLAT	4x1	纖維油石 For Fiber Stone
XH-061		6x1	
XH-101		10x1	
XH-062		6x2~6x3	一般油石 For Oil Stone
XH-133		13x3	
XH-136		13x6.3	

鑽石銼刀系列

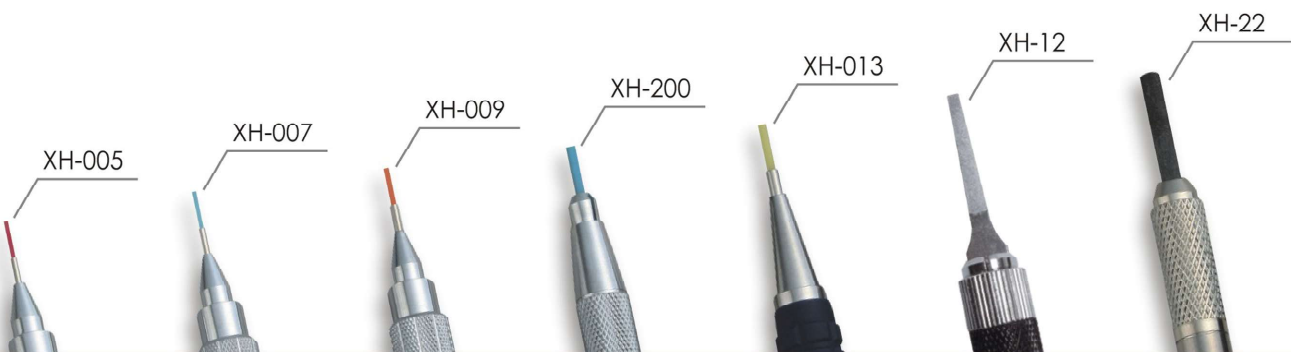

訂購編號	可夾持尺寸		運用
Order No.	Holding Capacity		Applications
XH-005	方形或圓形 Square or round	0.3x0.3或圓Ø0.5 0.3x0.3 or Round Ø0.5	迷你纖維油石 For Mini Fiber Stone
XH-007		0.5x0.5或圓Ø0.7 0.5x0.5 or Round Ø0.7	
XH-009		0.7x0.7或圓Ø0.9 0.7x0.7 or Round Ø0.9	
XH-200	平形或圓形 Flat or round	2x1或圓Ø2.0 2x1 or Round Ø2.0	機械用銼刀 / 彈性銼刀片 For Machine Taper Diamond Files / Flexible Files
XH-013	方形 Square	0.9x0.9	
XH-12	平形或圓形 Flat or round	T=1mm 或圓Ø3 T=1mm or Round Ø3	纖維油石 For Fiber Stone
XH-22	圓 Round	圓Ø3.0 Round Ø3.0	

鑽石工具系列 Diamond File Series

GS油石(Made in Japan) GS Polishing Stones

BLK (BLACK STONE)



細致，鋒利的研磨端，能迅速將模具細部完整加工。中軟硬度的Sic砥粒，不但可用于鑽石之成型，更適用於高標準要求的模具鏡面細部的修飾。同時也適用於硬質材料模具的研磨。This stone is made of medium soft SIC grains with sharp points designed to swiftly fit to detail forms of mold. It is best suitable to operations before diamond paste processing and best for mold which needs fine finishing, such as mirror finishing. Also suitable for polishing hard material mold.

品名	磨料	硬度	結合劑	尺寸	粒度	用途
Grain	Hardness	Bond	Size	Grit	Application	
BLK	C	中軟 (Medium Soft)	V	3x6x100 3x13x150 3x6x150 5x13x150	#120 #180 #240 #320 #400 #600 #800 #1000 #1200 #1500 #2000 #3000	一般模具 硬質材料模具等 General mold for hard material mold

GC (GC STONE)



綠色SIC砥粒加上特殊結合劑的超完美結合所制作出專門針對細部修飾，拋光的GC STONE，除了可以安穩的處理表層細微的紋路，更可用在超硬熱處理的鋼材修飾上。With green SIC grains mixed among special bond. This stone does not damage surface and give stable finishing. It is suitable for carbide and quenched steels.

品名	磨料	硬度	結合劑	尺寸	粒度	用途
Grain	Hardness	Bond	Size	Grit	Application	
GC	GC	中軟 (Medium Soft)	V	3x6x100 3x13x150 3x6x150 5x13x150 3x13x100	#120 #180 #240 #320 #400 #600 #800 #1000 #1200 #1500 #2000 #3000	一般模具及非鐵金屬， 硬質工具等 For nonferrous metals and hard material tools

EDM-BL (EDM STONE)



可輕易去除EDM后表面頑固的吸附粒子，却又不傷及模具表層。銳角部份及角落的細部研磨有著非常顯著性能的發揮。This special stone has higher hardness and less abrasion. It shows high performance for detailed polish, such as corners of acute angles.

品名	磨料	硬度	結合劑	尺寸	粒度	用途
Grain	Hardness	Bond	Size	Grit	Application	
EDM	WA	硬 (Hard)	V	1x10x100 3x13x150 3x6x100 5x13x150 3x6x150 6x6x150	#120 #180 #240 #320 #400 #600 #800 #1000 #1200	一般模具 及放電加工 后的表面研磨 Surface polish after EDM processing for general mold

訂購範例 GS BLK 36100 120 Order Ex GS BLK 36100 120
型號 產品代號 尺寸 粒度 Model No. Item Size Grit

GS油石 (Made in Japan) GS Polishing Stones

DIE (DIE STONE)



在硬度範圍HRC47-63的鋼材表面研磨上會有優秀并最適合的表現。超銳利的A級砥粒亦可用于切割，更適合硬質材料的研磨。

A best stone for quenched steel of HRC 47 to 63. Medium soft hardness of this stone give steel an excellent finishing and the sharp cutting of A grains enables polishing for hardened materials.

品名	磨料	硬度	結合劑	尺寸	粒度	用途
	Grain	Hardness	Bond	Size	Grit	Application
DIE	A	中軟 (MediumSoft)	V	3x6x150 5x13x150 3x13x150 6x6x150	#150 #180 #220 #320 #400 #600	淬鋼合金之表面研磨 Surface polishing for quenched steel

EDM-BR (LAP MATE EDM STONE)



密度高且耐磨的WA砥粒，在研磨過程中，可抑制最小量的粒子脫落。加上使用特殊的樹脂加工，可讓油石本身，尤其是研磨的先端常保如新。適用於細部的研磨或中度的修飾。
The Lap Mate is manufactured for keeping new blade constantly with minimum bonds and maximum density of grains to prevent from falling out. Due to our special processed resin, the form of the edge lasts long and can be used for detail finishing as well as rough and medium finishing.

品名	磨料	硬度	結合劑	尺寸	粒度	用途
	Grain	Hardness	Bond	Size	Grit	Application
EDM-BR	WA	中硬 (Medium Hard)	V	1x10x100 5x13x150 3x6x100 6x6x150 3x6x150 3x13x150	#120 #180 #240 #320 #400 #600 #800 #1000 #1200	一般模具及放電加工 后的表面研磨 Surface lapping after EDM processing for general mold

INDIA (INDIA STONE)



產地為美國，擁有豐富的油脂含量。適合各種刀具及工具的修整。

This stone, originally conveyed from the United States, contains rich oil and has sharp breaking ability. It is good for setting cutlery and finishing for various kinds of tools.

其他形狀 Other shapes

△三角(triangle) ○圓形(circle) ◐半圓(semicircle)

◇菱形(lozenge) ◌橢圓(oval) 3.2x100 4.5x100 6.4x100 8x100 etc.

△圓錐(cone) 6.4x100 8x100 9.5x100 13x100

品名	磨料	硬度	結合劑	尺寸	粒度	用途
	Grain	Hardness	Bond	Size	Grit	Application
INDIA	A	硬 H	V	13x25x100 25x50x150 25x50x200	FB(細目 / Fine) MB(中目 / Medium)	適用於各種刀具 Cutlery and all kinds of tools

訂購範例

GS	Die	36150	150	Order Ex	GS	Die	36150	150
型號	產品代號	尺寸	粒度		Model No.	Item	Size	Grit

鑽石工具系列 Diamond File Series

GS油石(Made in Japan) GS Polishing Stones

SO
(SUPER ORANGE STONE)



特別設計用于往覆式氣動工具及超音波研磨機，特殊橘色WA砥粒除了不易折斷的特性，更可維持研磨先端的鋒利，最適合用在EDM后硬化層附著物的去除。

Best stone for removing hardened layer after EDM processing. You can use this stone with stroke air profiler-linear machine and ultrasonic machine because this stone is very hard break. You can always keep new and sharp blade by avoiding grains to drop out with using original special bond. This original new bound makes it possible to remove hardened layer EDM processing.

品名	磨料	硬度	結合劑	尺寸	粒度	用途
	Grain	Hardness	Bond	Size	Grit	Application
SO	WA	中硬 (Medium Hard)	V	3x6x150 6x6x150 3x13x150 5x13x150	#120 #180 #220 #320 #400 #600	搭配使用往覆式氣動研磨機， 超音波研磨機效果更佳 Surface lapping after EDM processig for gneral. Use with stroke air profiler-linear

VH(Made in USA)
(GOLDEN STONE)



從選擇優質氧化鋁顆粒和專有的處理過程中，VH油石是中等硬度，具有快速去除工件表面紋路及保持油石低磨耗不變形，并留下了如絲般柔滑質感。VH油石并不需要漫長加工的過程也不需使用潤滑油，是款高效能的EDM油石。

Made from select premium aluminum oxide grain and a proprietary treatment process, the VH stone is of medium hardness with a fast breakdown offering quick material removal while contouring quickly and leaving a silky smooth finish. The VH stone does not require a lengthy pre-lubrication process and is terrific when used during hand stoning as well as with profilers.

品名	磨料	硬度	結合劑	尺寸	粒度	用途
	Grain	Hardness	Bond	Size	Grit	Application
VH	VH	中硬 (Medium Hard)	V	3x3x150 3x13x150 4x4x150 6x6x150 3x6x150 6x13x150	#150 #180 #240 #400 #600 #1200 #1500 #2500	放電加工后的表面和銑刀加工 痕迹更具有優异的去除性。 Delivering exceptional performance on EDM surfaces, milling and machining marks.

FLASH 600油石研磨液(Made in Japan) Flash 600 Stoning Oil

日本3A獨家研發傳統油石研磨液

FLASH 600 is originally developed by 3A-Sangyo

傳統油石加工時使用油石研磨液是非常重要的，因為它能有效的提升傳統油石的切削性及延長油石的壽命。

The role of the stoning oil is significantly important for the stick type Abrasive stone.

減低油石磨耗及降低摩擦時所產生的溫度使油石的壽命更長。

防止粉塵堵塞于油石氣孔中，使加工時的磨屑順利的排除不阻塞提升油石的切削性另可以防止模具損傷。

有效的提升傳統油石的切削性及延長油石的壽命。

配方温和不傷肌膚。

Strengthen the polishing power of the grains, reduce the abrasion of grains, cool down the friction heat and give the stones long life.

Protect work pieces from scratches by washing away polished wastes and felled down grains, keep new edge constantly and prevent the holes from clogging and crushing.

Maximize the sharpness and give the longest life for whetstones.

FLASH 600 is gentle for human skin of the hands and legs.

※部分油石及模具不需要使用研磨液，詳細內容可向本公司洽詢。

There are some stones and some cases which don't need stoning oil. Ask our salespersons on details.



容量：500 c.c
另有30 c.c小瓶裝可供選擇
30 c.c. is also available

訂購代號 FLASH600-500(500 c.c)
Order No. FLASH600-030(30 c.c)

TDF130 平斜鑽石銼刀 Tapered Diamond File

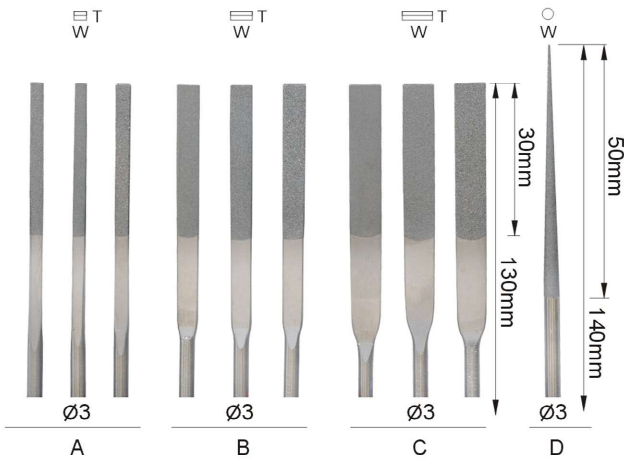

訂購編號 Order No.	形狀 Shape	全長 L	鑽石長度 B	寬度 W	厚度 T	柄徑 Shank	粒度 Grit
TDF-130A-200	A	130	30	2	0.4~1.7	Ø3	#200
TDF-130A-400							#400
TDF-130A-600							#600
TDF-130B-200	B	130	30	4	0.4~1.7	Ø3	#200
TDF-130B-400							#400
TDF-130B-600							#600
TDF-130C-200	C	140	50	3		Ø3	#200
TDF-130C-400							#400
TDF-130C-600							#600
TDF-130D-400	D	140	50	3		Ø3	#400
TDF-130S		10支組套裝/10 Pieces/Set(以上型號各1支)					

TDF170 平斜鑽石銼刀 Tapered Diamond File

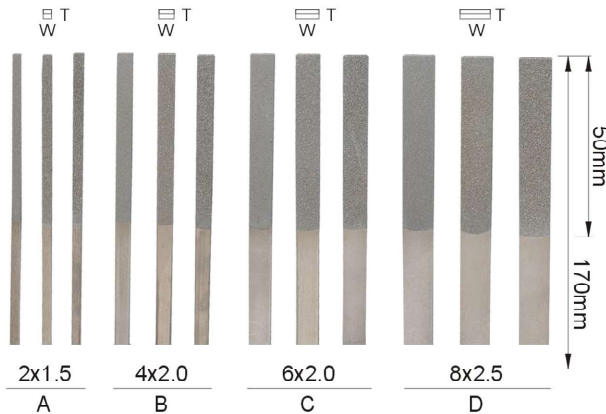

訂購編號 Order No.	形狀 Shape	全長 L	鑽石長度 B	寬度 W	厚度 T	柄徑 Shank	粒度 Grit
TDF-170A-120	A	170	50	2	0.4~1.5	2x1.5	#120
TDF-170A-200							#200
TDF-170A-400							#400
* TDF-170A-600							#600
TDF-170B-120	B	170	50	4	0.5~2.0	4x2.0	#120
TDF-170B-200							#200
TDF-170B-400							#400
* TDF-170B-600							#600
TDF-170C-120	C	170	50	6	0.5~2.0	6x2.0	#120
TDF-170C-200							#200
TDF-170C-400							#400
* TDF-170C-600							#600
TDF-170D-120	D	170	50	8	0.5~2.5	8x2.5	#120
TDF-170D-200							#200
TDF-170D-400							#400
* TDF-170D-600							#600
TDF-170S		12支組套裝/12 Pieces/Set(#600 不包含)					

*#600 is not included in a set

FDF140 平型鑽石銼刀 Flat Diamond File

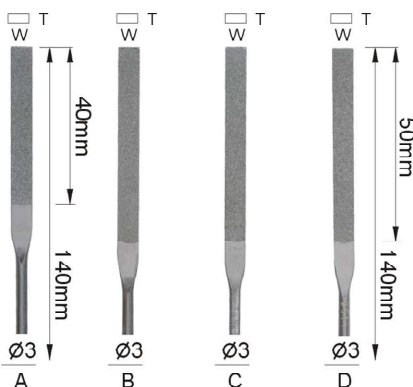

訂購編號 Order No.	形狀 Shape	全長 L	鑽石長度 B	寬度 W	厚度 T	柄徑 Shank	粒度 Grit
FDF-140A-粒度(Grit)	A	140	40	5.5	0.5	Ø3	#120
FDF-140B-粒度(Grit)	B		50		0.8		
FDF-140C-粒度(Grit)	C		50		1.0		
FDF-140D-粒度(Grit)	D		50		1.2		
FDF-140S-粒度(Grit)		4支組套裝/4 Pieces/Set(以上型號同粒度各1支)					

鑽石銼刀系列 Diamond File Series

NDF140 精密型鑽石銼刀 Needle Diamond File

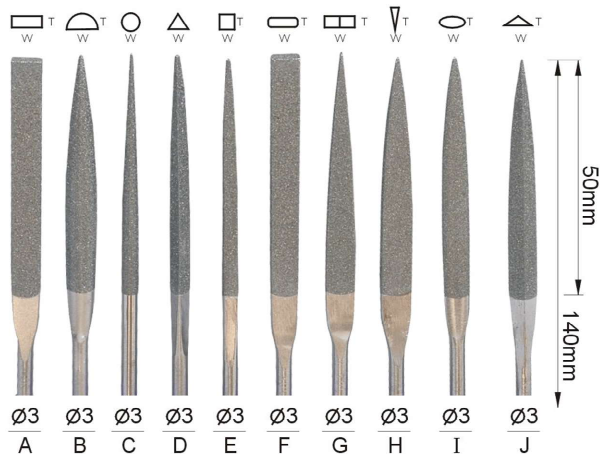

訂購編號 Order No.	形狀 Shape	全長 L	鑽石長度 B	寬度 W	厚度 T	柄徑 Shank	粒度 Grit
NDF-140A-粒度(Grit)	A	140	50	5.5	1.6	Ø3	#120 #200 #400
NDF-140B-粒度(Grit)	B			5	2		
NDF-140C-粒度(Grit)	C			3	3		
NDF-140D-粒度(Grit)	D			3.5	3.5		
NDF-140E-粒度(Grit)	E			2.5	2.5		
NDF-140F-粒度(Grit)	F			5.2	1.6		
NDF-140G-粒度(Grit)	G			5.5	1.3		
NDF-140H-粒度(Grit)	H			6	1.5		
NDF-140I-粒度(Grit)	I			5	2		
NDF-140J-粒度(Grit)	J			5	2.2		
NDF-140S-粒度(Grit)	10支組套裝/10 Pieces/Set(以上型號同粒度各1支)						

NDF180 精密型鑽石銼刀 Needle Diamond File

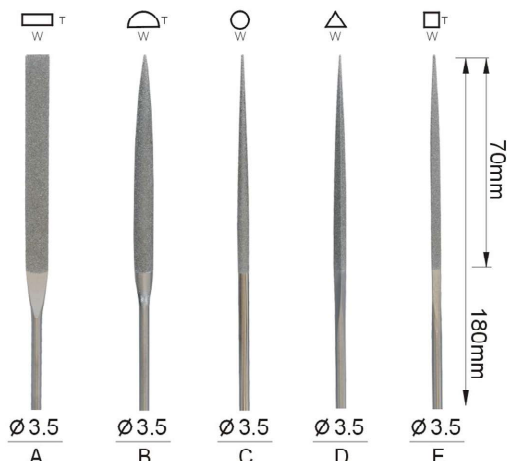

訂購編號 Order No.	形狀 Shape	全長 L	鑽石長度 B	寬度 W	厚度 T	柄徑 Shank	粒度 Grit
NDF-180A-粒度(Grit)	A	180	70	7.5	1.5	Ø3.5	#120 #200 #400
NDF-180B-粒度(Grit)	B			6	2.1		
NDF-180C-粒度(Grit)	C			3.5	3.5		
NDF-180D-粒度(Grit)	D			4	4		
NDF-180E-粒度(Grit)	E			3.4	3.4		
NDF-180S-粒度(Grit)	5支組套裝/5 Pieces/Set(以上型號同粒度各1支)						

NDF200 精密型鑽石銼刀 Needle Diamond File

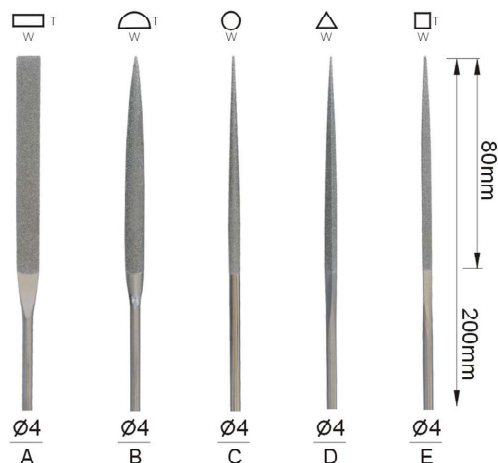

訂購編號 Order No.	形狀 Shape	全長 L	鑽石長度 B	寬度 W	厚度 T	柄徑 Shank	粒度 Grit
NDF-200A-粒度(Grit)	A	200	80	8.5	1.6	Ø4	#120 #200 #400
NDF-200B-粒度(Grit)	B			7	2.5		
NDF-200C-粒度(Grit)	C			4	4		
NDF-200D-粒度(Grit)	D			5	5		
NDF-200E-粒度(Grit)	E			3.5	3.5		
NDF-200S-粒度(Grit)	5支組套裝/5 Pieces/Set(以上型號同粒度各1支)						

MTDF80 機械用平斜鑽石銼刀 Machine Taper Diamond Files For Equipments

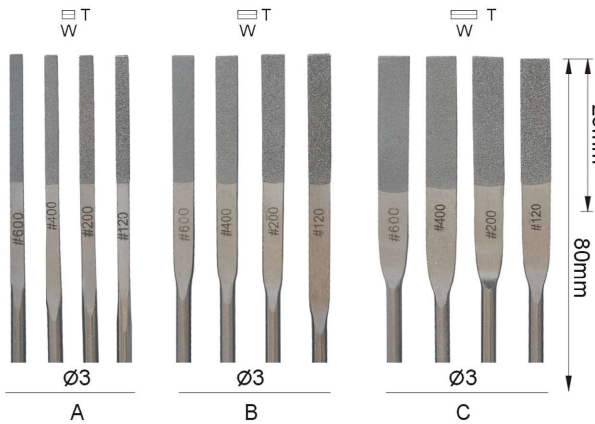

訂購編號 Order No.	形狀 Shape	全長 L	鑽石長度 B	寬度 W	厚度 T	柄徑 Shank	粒度 Grit	
MTDF-80A-120	A	80	25	3	0.5~1.4	Ø3	#120	
MTDF-80A-200							#200	
MTDF-80A-400							#400	
MTDF-80A-600							#600	
MTDF-80B-120	B			4			#120	
MTDF-80B-200								#200
MTDF-80B-400								#400
MTDF-80B-600								#600
MTDF-80C-120	C			6			#120	
MTDF-80C-200								#200
MTDF-80C-400								#400
MTDF-80C-600								#600
MTDF-80S		12支組套裝/12 Pieces/Set(以上型號各1支)						

相關工具

P F38



MTDFFA 鑽石彈性銼刀片 Machine Taper Diamond Flexible Files

Machine Taper Diamond Flexible Files

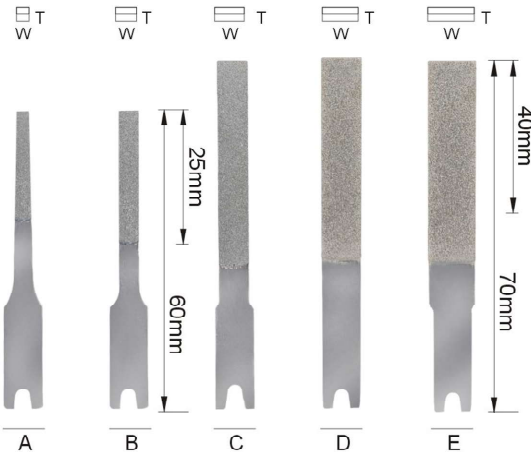

訂購編號 Order No.	形狀 Shape	全長 L	鑽石長度 B	寬度 W	厚度 T	粒度 Grit
MTDF-FAA-粒度(Grit)	A	60	25	2~6	0.5~1.0	#150
MTDF-FAB-粒度(Grit)	B			4		#200
MTDF-FAC-粒度(Grit)	C	70	40	6		#400
MTDF-FAD-粒度(Grit)	D			8		#600
MTDF-FAE-粒度(Grit)	E			10		

相關工具

P F38



HDDF215 鐵工用鑽石銼刀 Heavy Duty Diamond Files

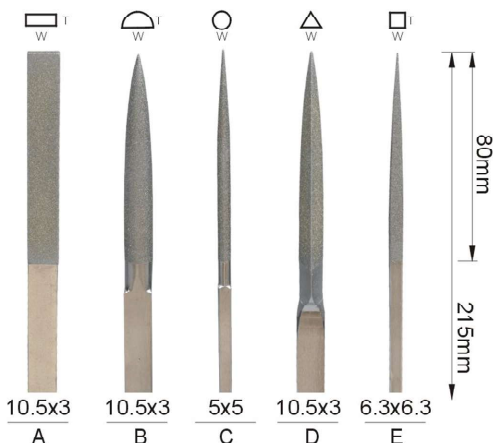

訂購編號 Order No.	形狀 Shape	全長 L	鑽石長度 B	寬度 W	厚度 T	柄徑 Shank	粒度 Grit
HDDF-215A-100	A	215	80	11	3.5	10.5x3	#120
HDDF-215B-100	B			10.5	4.4	10.5x3	
HDDF-215C-100	C			5	5	5x5	
HDDF-215D-100	D			7.7	7.7	10.5x3	
HDDF-215E-100	E			5.1	5.1	5x5	
HDDF-215S-100		5支組套裝/5 Pieces/Set(以上型號同粒度各1支)					

鑽石銼刀系列 Diamond File Series

RDFA140 異型鑽石銼刀 Radian Diamond Files

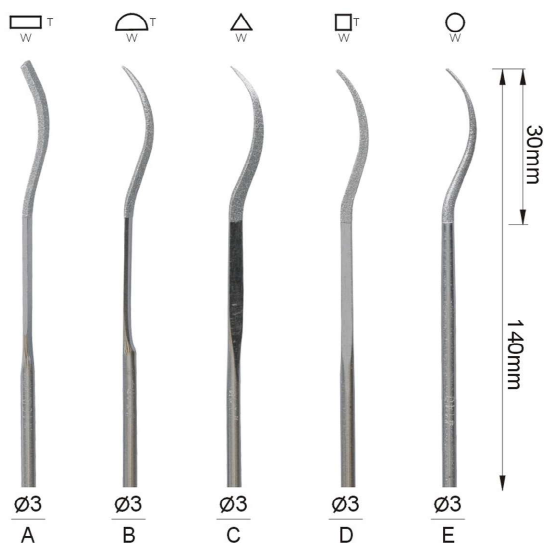

訂購編號 Order No.	形狀 Shape	全長 L	鑽石長度 B	寬度 W	厚度 T	柄徑 Shank	粒度 Grit
RDFA-140A-粒度(Grit)	A	140	30	6	1.5	Ø3	#150
RDFA-140B-粒度(Grit)	B			5	2		
RDFA-140C-粒度(Grit)	C			3.5	3.5		
RDFA-140D-粒度(Grit)	D			2.5	2.5		
RDFA-140E-粒度(Grit)	E			3	3		
RDFA-140S-粒度(Grit)	5支組套裝/5 Pieces/Set(以上型號同粒度各1支)						

RDFB150 異型鑽石雙頭銼刀 Radian Diamond Files

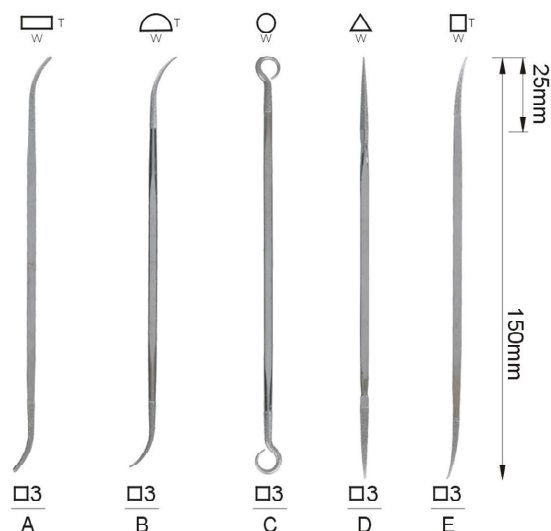

訂購編號 Order No.	形狀 Shape	全長 L	鑽石長度 B	寬度 W	厚度 T	柄徑 Shank	粒度 Grit
RDFB-150A-粒度(Grit)	A	150	25	3	2	□3	#120 #200
RDFB-150B-粒度(Grit)	B		25	2	2		
RDFB-150C-粒度(Grit)	C		20	2	2		
RDFB-150D-粒度(Grit)	D		25	3	3		
RDFB-150E-粒度(Grit)	E		20	2.5	2.5		
RDFB-150S-粒度(Grit)	5支組套裝/5 Pieces/Set(以上型號同粒度各1支)						

RDFC150 異型鑽石銼刀 Radian Diamond Files

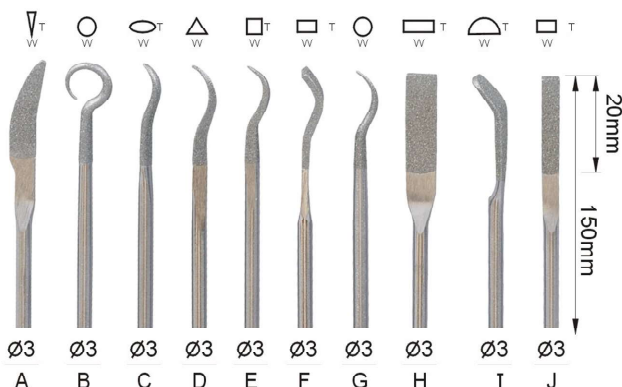

訂購編號 Order No.	形狀 Shape	全長 L	鑽石長度 B	寬度 W	厚度 T	柄徑 Shank	粒度 Grit
RDFC-150A-粒度(Grit)	A	140	20	5	1.2	Ø3	#120 #200 #400
RDFC-150B-粒度(Grit)	B			2	2		
RDFC-150C-粒度(Grit)	C			4	2		
RDFC-150D-粒度(Grit)	D			3	3		
RDFC-150E-粒度(Grit)	E			2.5	2.5		
RDFC-150F-粒度(Grit)	F			3	1.2		
RDFC-150G-粒度(Grit)	G			2	2		
RDFC-150H-粒度(Grit)	H			6	1.2		
RDFC-150I-粒度(Grit)	I			5	1.6		
RDFC-150J-粒度(Grit)	J			3	1.2		
RDFC-150S-粒度(Grit)	10支組套裝/10 Pieces/Set(以上型號同粒度各1支)						

MRDF65 機械用異型鑽石銼刀 Machine Radian Diamond Files For Equipments

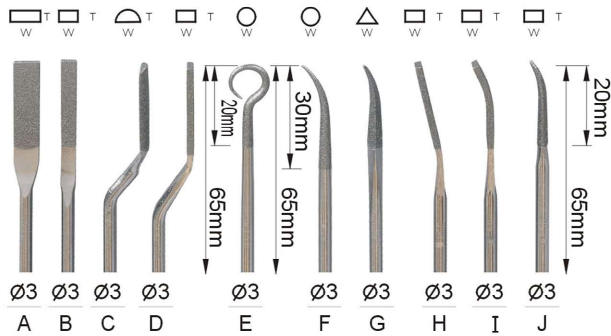

訂購編號 Order No.	形狀 Shape	全長 L	鑽石長度 B	寬度 W	厚度 T	柄徑 Shank	粒度 Grit	
MRDF-65A-粒度(Grit)	A	65	20	5.8	1.2	Ø3	#150 #200	
MRDF-65B-粒度(Grit)	B			3.2	1.4			
MRDF-65C-粒度(Grit)	C			5	2			
MRDF-65D-粒度(Grit)	D			3.2	1.4			
MRDF-65E-粒度(Grit)	E			3	3			
MRDF-65F-粒度(Grit)	F			30	3			3
MRDF-65G-粒度(Grit)	G			3	3			
MRDF-65H-粒度(Grit)	H			20	3.2			1.4
MRDF-65I-粒度(Grit)	I			3.2	1.4			
MRDF-65J-粒度(Grit)	J			4	2			
MRDF-65S-粒度(Grit)	10支組套裝/10 Pieces/Set(以上型號同粒度各1支)							

相關工具



PTDF 搪孔棒 Internal Boring Diamond Files

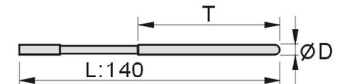

訂購編號 Order No.	外徑 OD	全長 L	鑽石長度 B	粒度 Grit
PTDF-140-10-100	1.0	140	80	#100
PTDF-140-11-100	1.1			
PTDF-140-12-100	1.2			
PTDF-140-13-100	1.3			
PTDF-140-14-100	1.4			

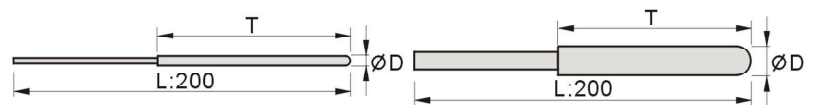

訂購編號 Order No.	外徑 OD	全長 L	鑽石長度 B	粒度 Grit
PTDF-200-(15~50)-100	1.5~5.0	200	120	#100
PTDF-200-(51~60)-100	5.1~6.0			
PTDF-200-(61~70)-100	6.1~7.0			

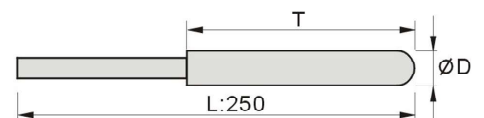

訂購編號 Order No.	外徑 OD	全長 L	鑽石長度 B	粒度 Grit
PTDF-250-(71~80)-100	7.1~8.0	250	120	#100
PTDF-250-(81~90)-100	8.1~9.0			
PTDF-250-(91~100)-100	9.1~10.0			

*Advise O.D.size when ordering
*訂購時請告知外徑尺寸

鑽石工具系列 Diamond File Series

DDC

圓錐修刀 Coned Diamond Dressers



適用於傳統砂輪(PA,WA,GA...等)精密研修,可搭配以下產品使用。
Application: For surface dressing of Aluminum oxide grinding wheels, like PA, WA, GA... wheels.
It is perfect to use together with following equipments.



沖子成型器、角度修整器、厚度修整器、角度成型器...等
Punch former, angle dresser, duplex dresser and angle sine dresser...

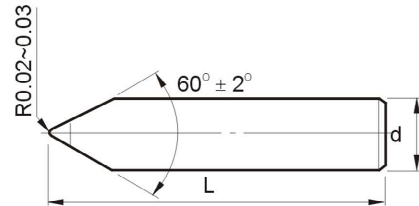

材質(柄) SK4 頂端 天然鑽石
Material (Shank): SK4 Tip: Natural Diamond

訂購代號	柄徑	全長
Order No.	Diameter	Length
DDC-001	3.175	25.4
DDC-002	3.175	50
DDC-003	6.35	50
DDC-004	9.53	50
DDC-005	10	50

鑽石工具系列

DDP

角錐修刀 Pyramid Dressers



001 002 003 004

適用於內圓砂輪精修,以上為常用規格
Application: For precision dressing of internal grinding wheels.

材質(柄) SK4 頂端 天然鑽石
Material (Shank): SK4 Tip: Natural Diamond

訂購代號	柄徑	全長
Order No.	Diameter	Length
DDP-001	Ø10	50
DDP-002	Ø12	50L / 100L
DDP-003	Ø6	22L
DDP-004	Ø8	23L

DDM

多石修刀 Multi Point Diamond Dressers

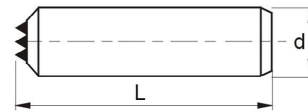

適用於傳統砂輪(PA,WA,GA...等平面研磨)

Application: For surface dressing of Aluminum oxide grinding wheels, like PA, WA, GA... wheels.

訂購代號	鑽石顆數	柄徑	鑽石分布
Order No.	Diamond Quantity	Shank	Diamond Distribution
DDM-03101	3	Ø12 x 100L	▲▲▲
DDM-03102	3		▲▲▲
DDM-05101	5		▲▲▲▲▲
DDM-06101	6		▲▲▲▲▲▲
DDM-07101	7		▲▲▲▲▲▲▲

DDS

單石修刀 Single Diamond Dressers

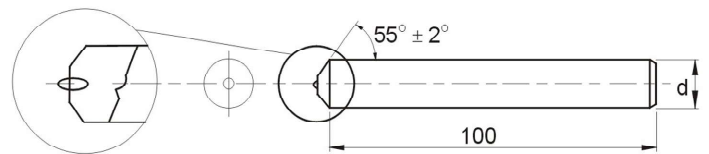

安裝及使用 / Installation and operation



進刀角度



進刀幅度

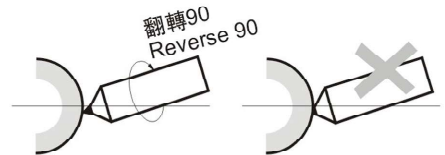

適時翻轉刀具

操作不當導致鑽石剝落

材質(柄) SK4
Material (Shank): SK4

頂端 天然鑽石
Tip: Natural Diamond

訂購代號	鑽石番號	適用砂輪	柄徑
Order No.	Diamond weight code	Grinding Wheels Size(mm)	Shank
DDS-010	#2 / 0.10cts	Ø150x25 or smaller	Ø10x80L (A) or Ø12x100L (B)
DDS-012	#3 / 0.12cts		
DDS-015	#4 / 0.15cts		
DDS-018	#5 / 0.18cts		
DDS-020	#10 / 0.20cts		
DDS-025	#15 / 0.25cts	Ø150~Ø300x25	Ø12x100L (B)
DDS-035	#20 / 0.35cts		
DDS-050	#25 / 0.50cts		
DDS-075	#33 / 0.75cts	Ø300~Ø450x25~40	
DDS-100	#50 / 1.0cts		
DDS-150	#75 / 1.5cts		
DDS-200	#100 / 2.0cts	Ø600 or larger	

訂購範例
Order Ex DDS-020-A(or B)

鑽石工具系列 Diamond File Series

DDI

組合修刀 Impregnated Diamond Dressers



訂購代號	粒度	齒塊	鐵柄形狀	鐵柄尺寸	適用範圍
Order No.	Grit	Diamond Tips	Type(Shank)	Shank	Applications
DDI-2AFC	F			ø12x100 ø12X50	無心研磨、圓筒研磨 平面研磨 砂輪尺寸: ø300x25~ø500x63
DDI-2AMC	M				
DDI-2ARC	R				
DDI-2AFD	F				
DDI-2AMD	M				
DDI-2ARD	R				
DDI-1CFG	F			ø10x50(A) ø12X50(B)	一般用途之研磨 砂輪尺寸: ø300及以下 For general purpose grinding. Wheel size ø300 and smaller
DDI-1CMG	M				
DDI-1CRG	R				

鑽石工具系列

DDH

手持式結合修刀 Hand Diamond Dressers

訂購代號	粒度	鑽石齒塊	型式
Order No.	Grit Size	Diamond Tips	Form
DDH-01R	R		<p>總長/Total length:160mm</p>
DDH-01F	F		
DDH-02R	R		<p>總長/Total length:200mm</p>
DDH-02F	F		
			方向① direction① 或 or 方向② direction②

粒度說明 / Grit Instruction

鑽石粒度 Diamond Grit		適用被修整砂輪粒度 Grinding wheel grit in operation
R 粗目 Coarse	#16/20 + #20/30	#60以下(#60 or Coarser)
M 中目 Medium	#30/50	#80~#120
F 細目 Fine	#50/80	#150以上(#150 or finer)

BDS/BBS 鑽石磨棒 Diamond Burrs

3mm柄套裝組系列10支套裝組 3mm Shank Kit 10 Pieces / Set

訂購編號 BDS-3-10(DIAMOND)
Order No. BBS-3-10(CBN)

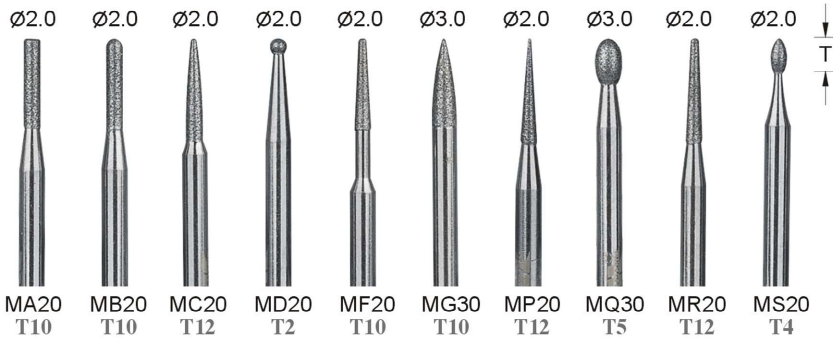

3mm柄套裝組系列20支套裝組 3mm Shank Kit 20 Pieces / Set

訂購編號 BDS-3-20(DIAMOND)
Order No. BBS-3-20(CBN)

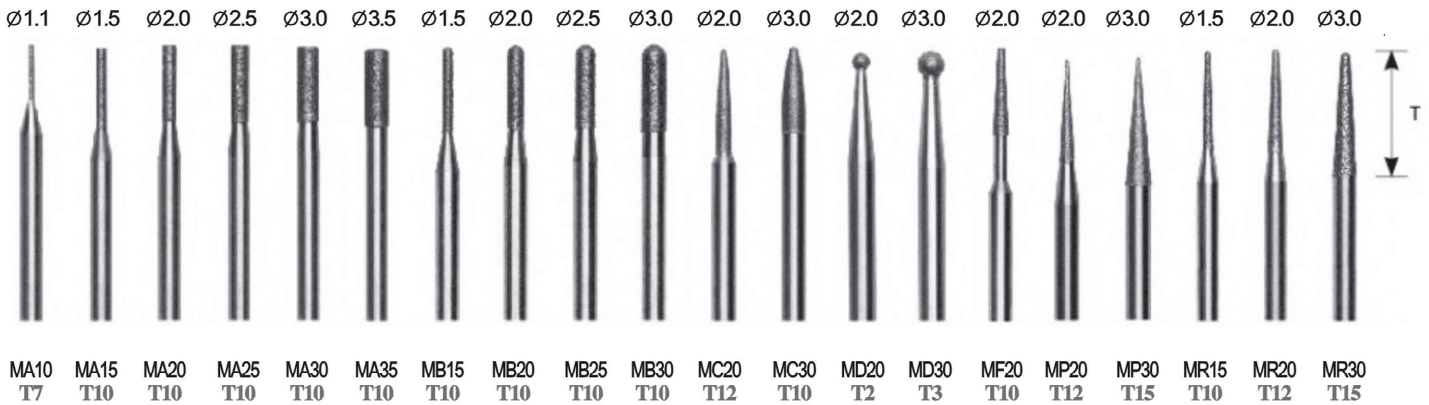

3mm柄套裝組系列30支套裝組 3mm Shank Kit 30 Pieces / Set

訂購編號 BDS-3-30(DIAMOND)
Order No. BBS-3-30(CBN)

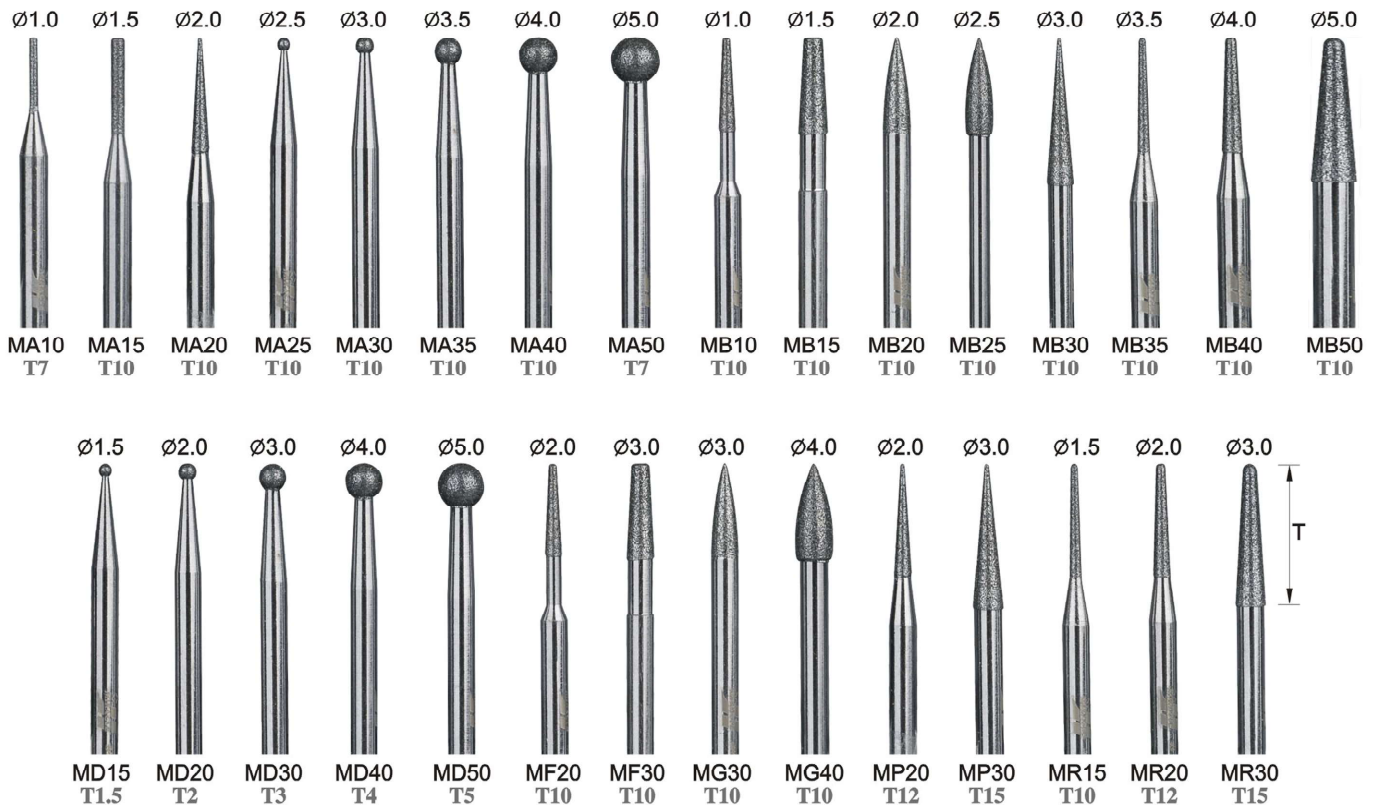

鑽石工具系列

鑽石磨棒 Diamond Burrs

M

鑽石磨棒 Diamond Burrs

圓柱形

Cylindrical Type

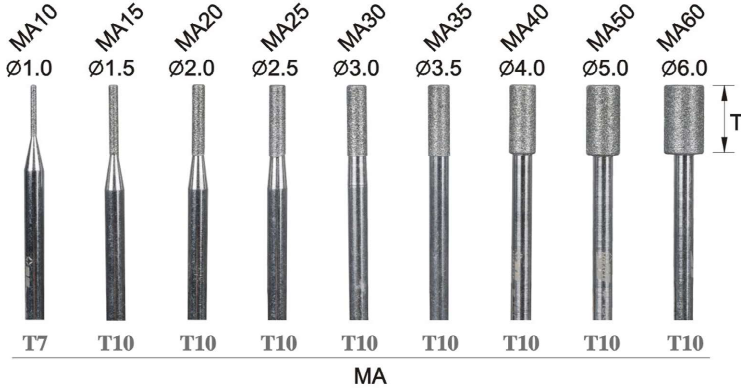

桃形

Round End Taper Type

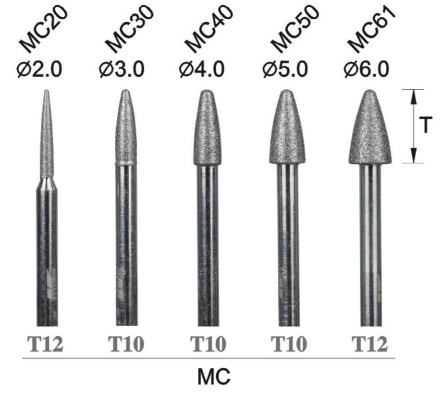

R形

Round End Type

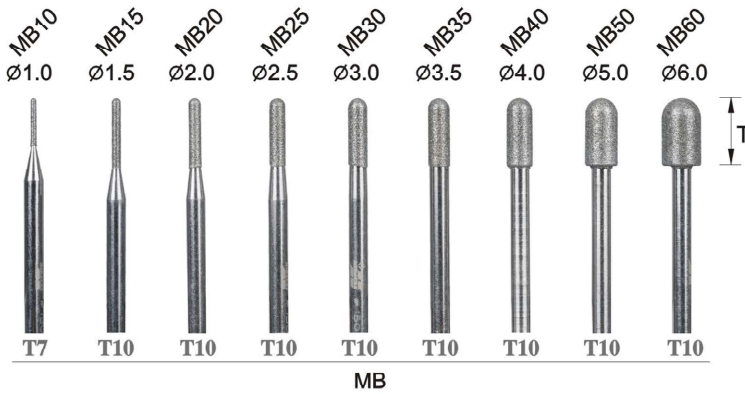

平斜形

Flat End Type

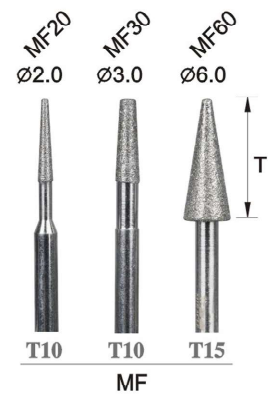

球形

Ball Type



桃尖形

Needle End Taper Type

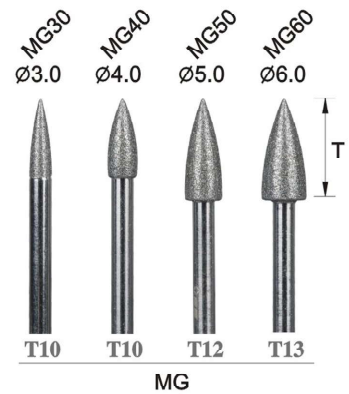

- O.D. 1.0~3.5 with #150
- O.D. >4.0 with #120
- 5pcs / pack

鑽石工具系列

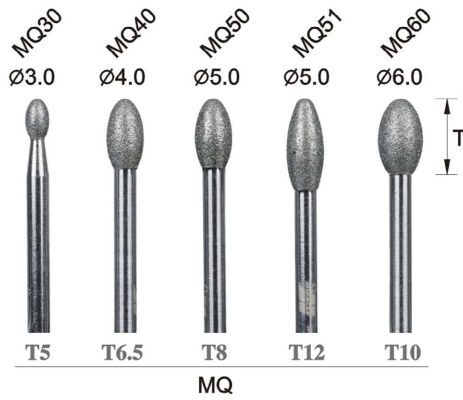
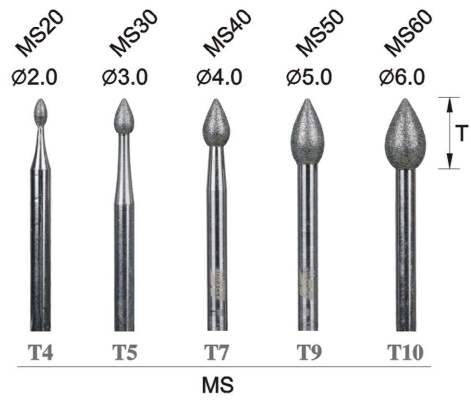
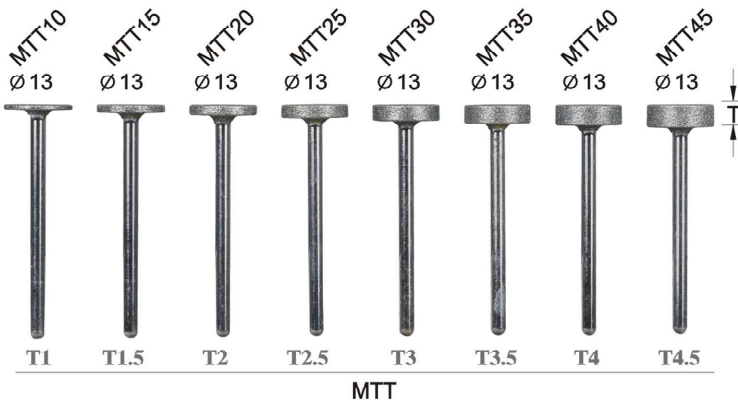
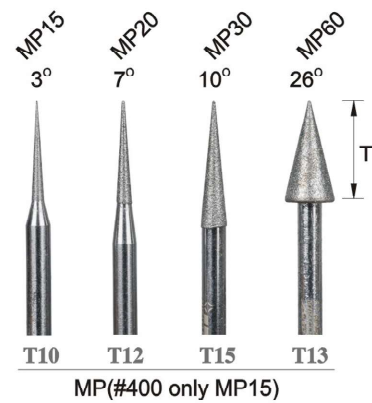
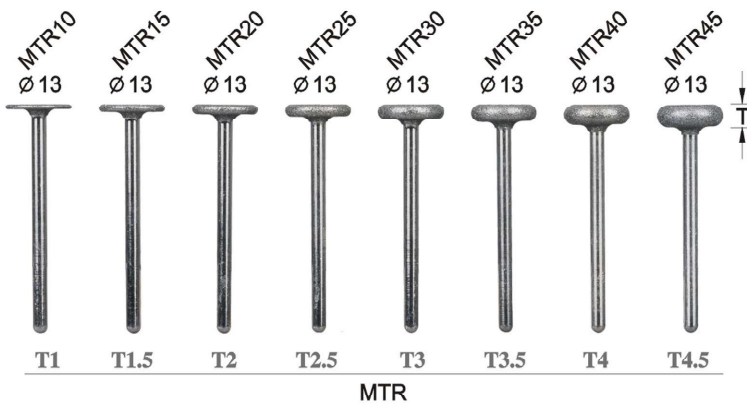
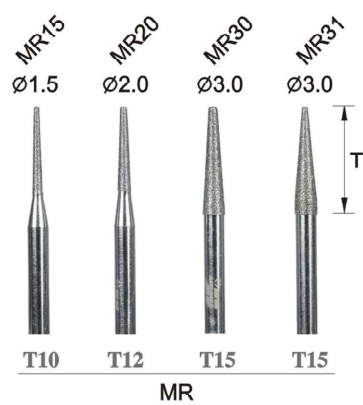
**蛋形
Egg Type**

**火焰形
Match Type**

**T 平形
Flat Type**

**尖形
Needle End Type**

**TR形
Round T Type**

**錐形
Conical Type**

- O.D. 1.0~3.5 with #150
- O.D. >4.0 with #120
- 5pcs / pack

鑽石工具系列 Diamond File Series

MM

鑽石及氮化硼(CBN)內孔研磨輪 柄徑3mm

Diamond & CBN Mandrels(3mm Shank)

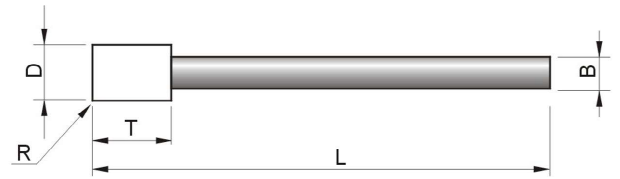
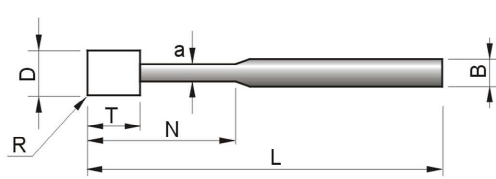

訂購編號 Order No.		外徑 D	厚度 T	N	全長 L	B	#100	#140	#200	#325	#400
鑽石 DIA	氮化硼 CBN										
MMD-3003	MMB-3003	0.3	2	3	35	3	x	x	x	x	○
MMD-3004	MMB-3004	0.4	2	3.5	35	3	x	x	x	x	○
MMD-3005	MMB-3005	0.5	2	3.5	35	3	x	x	x	○	○
MMD-3006	MMB-3006	0.6	2	6	35	3	x	x	○	○	○
MMD-3007	MMB-3007	0.7	2	7	35	3	x	x	○	○	○
MMD-3008	MMB-3008	0.8	3	7	35	3	x	○	○	○	○
MMD-3009	MMB-3009	0.9	3	7	35	3	x	○	○	○	○
MMD-3010	MMB-3010	1.0	3	7	45	3	x	○	○	○	○
MMD-3011	MMB-3011	1.1	3	7	45	3	x	○	○	○	○
MMD-3012	MMB-3012	1.2	3	12	45	3	x	○	○	○	○
MMD-3013	MMB-3013	1.3	3	12	45	3	x	○	○	○	○
MMD-3014	MMB-3014	1.4	3	12	45	3	○	○	○	○	○
MMD-3015	MMB-3015	1.5	3	13	45	3	○	○	○	○	○
MMD-3016	MMB-3016	1.6	4	13	45	3	○	○	○	○	○
MMD-3017	MMB-3017	1.7	4	13	45	3	x	○	○	○	○
MMD-3018	MMB-3018	1.8	4	13	45	3	○	○	○	○	○
MMD-3019	MMB-3019	1.9	4	13	45	3	○	○	○	○	○
MMD-3020	MMB-3020	2.0	4	13	45	3	○	○	○	○	○
MMD-3920	MMB-3920	2.0	5	20	45	3	○	○	○	○	○
MMD-3021	MMB-3021	2.1	4	13	45	3	○	○	○	○	○
MMD-3022	MMB-3022	2.2	4	13	45	3	○	○	○	○	○
MMD-3023	MMB-3023	2.3	4	13	45	3	○	○	○	○	○
MMD-3024	MMB-3024	2.4	4	13	45	3	○	○	○	○	○
MMD-3025	MMB-3025	2.5	4	13	45	3	○	○	○	○	○
MMD-3925	MMB-3925	2.5	5	25	45	3	○	○	○	○	○
MMD-3026	MMB-3026	2.6	4	13	45	3	○	○	○	○	○
MMD-3027	MMB-3027	2.7	4	13	45	3	○	○	○	○	○
MMD-3028	MMB-3028	2.8	4	13	45	3	○	○	○	○	○
MMD-3029	MMB-3029	2.9	4	13	45	3	○	○	○	○	○
MMD-3030	MMB-3030	3.0	5	13	45	3	○	○	○	○	○
MMD-3930	MMB-3930	3.0	5	25	45	3	○	○	○	○	○
MMD-3035	MMB-3035	3.5	5		45	3	○	○	○	○	○
MMD-3040	MMB-3040	4.0	5		45	3	○	○	○	○	○
MMD-3045	MMB-3045	4.5	5		45	3	○	○	○	○	○
MMD-3050	MMB-3050	5.0	8		45	3	○	○	○	○	○
MMD-3060	MMB-3060	6.0	8		45	3	○	○	○	○	○

訂購範例 Order Ex MMD 型號 Model No. 3010 尺寸 Size 140 粒度 Grit

鑽石工具系列

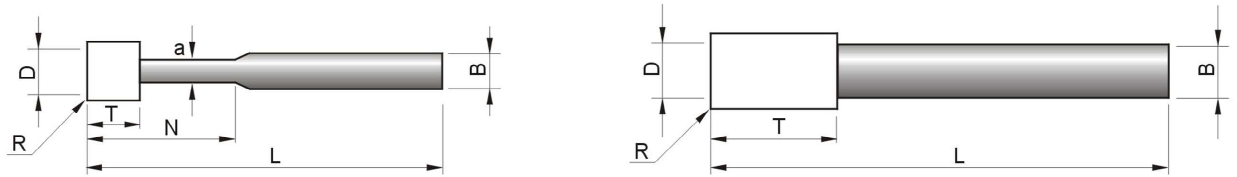

訂購編號 Order No.		外徑 D	厚度 T	N	全長 L	B	#100	#140	#200	#325	#400
鑽石 DIA	氮化硼 CBN										
MMD-6020	MMB-6020	2.0	10	30	80	6	○	○	○	○	○
MMD-6025	MMB-6025	2.5	10	30	80	6	○	○	○	○	○
MMD-6030	MMB-6030	3.0	10	30	80	6	○	○	○	○	○
MMD-6035	MMB-6035	3.5	10	30	80	6	○	○	○	○	○
MMD-6040	MMB-6040	4.0	10	30	80	6	○	○	○	○	○
MMD-6045	MMB-6045	4.5	10	30	80	6	○	○	○	○	○
MMD-6050	MMB-6050	5.0	10	30	80	6	○	○	○	○	○
MMD-6055	MMB-6055	5.5	10	30	80	6	○	○	○	○	○
MMD-6060	MMB-6060	6.0	10	35	80	6	○	○	○	○	○
MMD-6065	MMB-6065	6.5	10		80	6	○	○	○	○	○
MMD-6070	MMB-6070	7.0	10		80	6	○	○	○	○	○
MMD-6075	MMB-6075	7.5	10		80	6	○	○	○	○	○
MMD-6080	MMB-6080	8.0	10		80	6	○	○	○	○	○
MMD-6085	MMB-6085	8.5	10		80	6	○	○	○	○	○
MMD-6090	MMB-6090	9.0	10		80	6	○	○	○	○	○
MMD-6100	MMB-6100	10.0	10		80	6	○	○	○	○	○
MMD-6110	MMB-6110	11.0	10		80	6	○	○	○	○	○
MMD-6120	MMB-6120	12.0	10		80	6	○	○	○	○	○
MMD-6130	MMB-6130	13.0	10		80	6	○	○	○	○	○
MMD-6140	MMB-6140	14.0	10		80	6	○	○	○	○	○
MMD-6150	MMB-6150	15.0	10		80	6	○	○	○	○	○
MMD-6160	MMB-6160	16.0	10		80	6	○	○	○	○	○
MMD-6170	MMB-6170	17.0	10		80	6	○	○	○	○	○
MMD-6180	MMB-6180	18.0	10		80	6	○	○	○	○	○
MMD-6200	MMB-6200	20.0	10		80	6	○	○	○	○	○
MMD-6210	MMB-6210	21.0	10		80	6	○	○	○	○	○
MMD-6220	MMB-6220	22.0	10		80	6	○	○	○	○	○
MMD-6250	MMB-6250	25.0	10		80	6	○	○	○	○	○

訂購範例 Order Ex MMD 型號 Model No. 6020 尺寸 Size 140 粒度 Grit

鎢鋼滾磨刀 Solid Carbide

SA圓筒型

Cylinder Shape

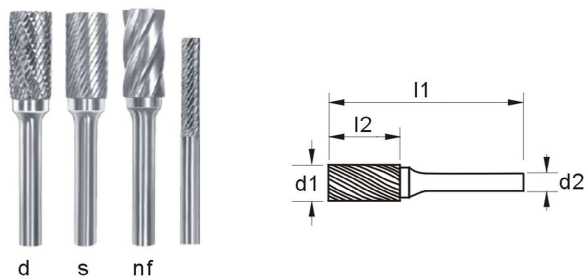

訂購編號 Order No.	Cutting Dia	Shank Dia	Length of Cut	Overall Length
	d1 mm	d2 mm	l2 mm	l1 mm
SA-41M	1.5	3	6	38
SA-42M	2.5	3	11	38
SA-43M	3	3	14	38
SA-51M	6	3	12	51
SA-51M/EC	6	3	12	50
SA-52M	4	3	13	39
SA-53M	5	3	12.7	38
SA-13M	4	6	16	50
SA-14M	5	6	16	50
SA-1M	6	6	16	50
SA-2M	8	6	19	63
SA-3M	9.5	6	19	63
SA-5M	12.7	6	25	69
SA-6M	16	6	25	69
SA-7M	19	6	25	69
SA-9M	25	6	25	69

SB圓筒型 / EC

Cylinder Shape / EC

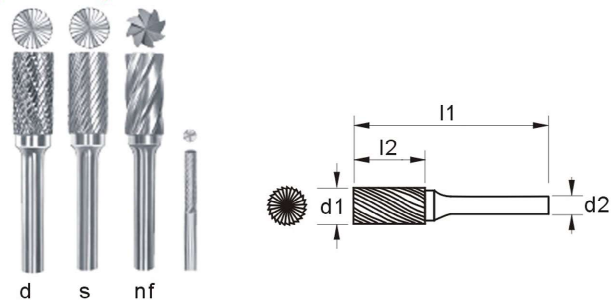

訂購編號 Order No.	Cutting Dia	Shank Dia	Length of Cut	Overall Length
	d1 mm	d2 mm	l2 mm	l1 mm
SB-43M	3	3	14	38
SB-51M	6	3	4.7	43
SB-13M	4	6	16	50
SB-14M	5	6	16	50
SB-1M	6	6	16	50
SB-2M	8	6	19	63
SB-3M	9.5	6	19	63
SB-5M	12.7	6	25	69
SB-6M	16	6	25	69
SB-7M	19	6	25	69
SB-9M	25	6	25	69

SC圓筒R型

Cylinder Shape Radius End

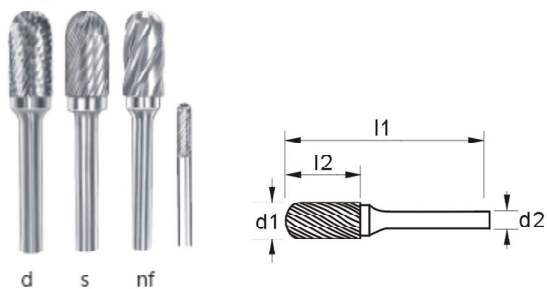

訂購編號 Order No.	Cutting Dia	Shank Dia	Length of Cut	Overall Length
	d1 mm	d2 mm	l2 mm	l1 mm
SC-41M	2.5	3	11	38
SC-42M	3	3	14	38
SC-51M	6.3	3	12.7	50
SC-52M	4	3	12.7	39
SC-53M	5	3	13	39
SC-13M	4	6	16	50
SC-14M	5	6	16	50
SC-1M	6	6	16	50
SC-2M	8	6	19	63
SC-3M	9.5	6	19	63
SC-5M	12.7	6	25	69
SC-6M	16	6	25	69
SC-7M	19	6	25	69
SC-9M	25	6	25	69

SD球型

Ball Shape

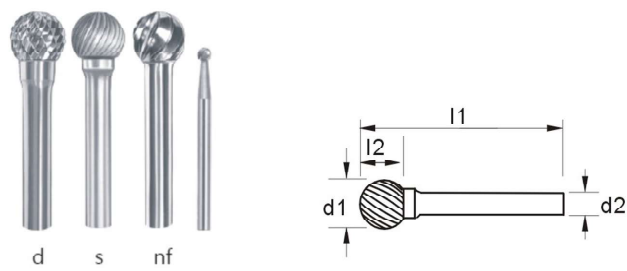

訂購編號 Order No.	Cutting Dia	Shank Dia	Length of Cut	Overall Length
	d1 mm	d2 mm	l2 mm	l1 mm
SD-41M	2.5	3	2.5	38
SD-42M	3	3	2.8	38
SD-51M	6.3	3	5	44
SD-52M	4	3	3.8	39
SD-53M	5	3	4.7	39
SD-14M	5	6	4	50
SD-1M	6	6	5	50
SD-2M	8	6	6.4	50
SD-3M	9.5	6	8	52
SD-5M	12.7	6	11	55
SD-6M	16	6	14	58
SD-7M	19	6	16	62
SD-9M	25	6	21	72

*d:交叉紋(標準品)

*s:單斜紋(訂制品)

*nf:鋁質及銅質用(僅提供6mm柄)

*d:double cut(standard)

*s:single cut(custom made)

*nf:nonferrous(only available for 6mm shank)

SE蛋型
Oval Shape

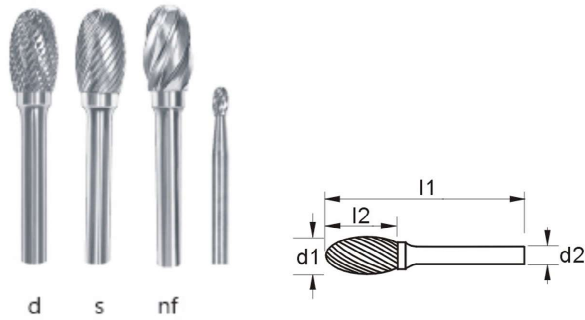

訂購編號 Order No.	Cutting Dia	Shank Dia	Length of Cut	Overall Length
	d1 mm	d2 mm	l2 mm	l1 mm
SE-41M	3	3	5.5	38
SE-51M	6.3	3	9.5	51
SE-53M	5	3	7.1	39
SE-1M	6	6	9.5	50
SE-3M	9.5	6	16	60
SE-5M	12.7	6	22	66
SE-6M	16	6	25	69
SE-7M	19	6	25	69

SF桃型
Tree Shape

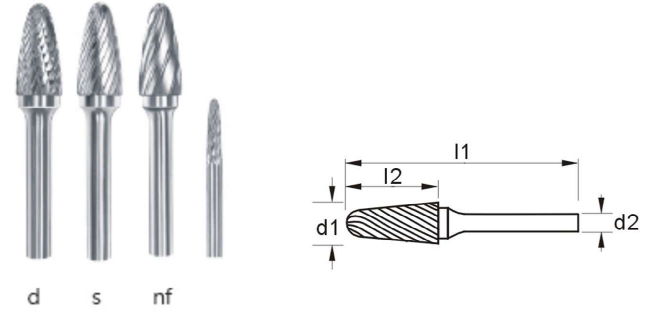

訂購編號 Order No.	Cutting Dia	Shank Dia	Length of Cut	Overall Length
	d1 mm	d2 mm	l2 mm	l1 mm
SF-41M	3	3	6	38
SF-42M	3	3	12	38
SF-51M	6.3	3	12.7	51
SF-53M	5	3	13	38
SF-14M	19	6	32	76
SF-15M	19	6	38	82
SF-1M	6	6	16	50
SF-3M	9.5	6	19	63
SF-5M	12.7	6	25	69
SF-6M	16	6	25	69
SF-7M	19	6	25	69

SG桃尖型
Tree Shape Pointed End

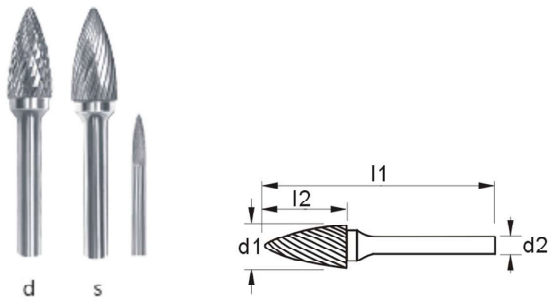

訂購編號 Order No.	Cutting Dia	Shank Dia	Length of Cut	Overall Length
	d1 mm	d2 mm	l2 mm	l1 mm
SG-41M	3	3	6	38
SG-43M	3	3	10	38
SG-44M	3	3	12	38
SG-51M	6.3	3	12	51
SG-53M	5	3	13	39
SG-1M	6	6	16	50
SG-2M	8	6	16	63
SG-3M	9.5	6	19	63
SG-5M	12.7	6	25	69
SG-6M	16	6	25	69
SG-7M	19	6	25	69
SC-15M	19	6	38	82

SH火焰型
Flame Shape

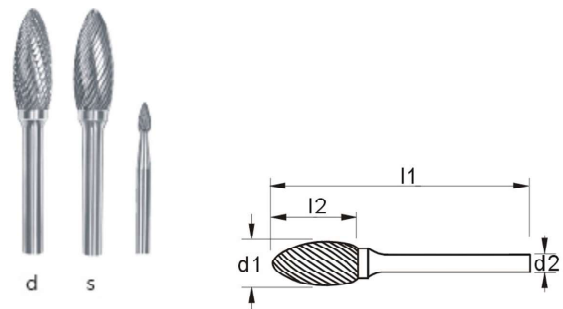

訂購編號 Order No.	Cutting Dia	Shank Dia	Length of Cut	Overall Length
	d1 mm	d2 mm	l2 mm	l1 mm
SH-41M	3	3	6.3	38
SH-53M	5	3	9.5	39
SH-2M	8	6	19	63
SH-5M	12.7	6	32	76
SH-6M	16	6	36	80
SH-7M	19	6	41	85

*d:交叉紋(標準品)
*s:單斜紋(訂制品)
*nf:鋁質及銅質用(僅提供6mm柄)

*d:double cut(standard)
*s:single cut(custom made)
*nf:nonferrous(only available for 6mm shank)

鎢鋼滾磨刀 Solid Carbide

SL錐R型

Taper Shape-Radius End



d s nf

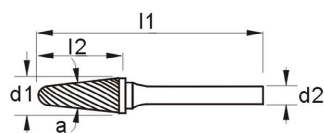

訂購編號 Order No.	Cutting Dia	Shank Dia	Length of Cut	Overall Length	Angle
	d1 mm	d2 mm	l2 mm	l1 mm	a
SL-41M	3	3	6.5	38	8°
SL-42M	3	3	12.7	38	8°
SL-53M	5	3	12.7	38	14°
SL-1M	6	6	16	50	14°
SL-2M	8	6	22	69	14°
SL-3M	9.5	6	27	74	14°
SL-4M	12.7	6	28	76	14°
SL-5M	16	6	30	77	14°
SL-7M	19	6	38	85	14°

SN皇冠型

Inverted Cone Shape



d s

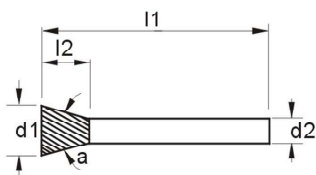

訂購編號 Order No.	Cutting Dia	Shank Dia	Length of Cut	Overall Length	Angle
	d1 mm	d2 mm	l2 mm	l1 mm	a
SN-41M	2.5	3	3	38	10°
SN-42M	3	3	4	38	10°
SN-51M	6.3	3	6	51	10°
SN-53M	5	3	6.3	38	10°
SN-1M	6	6	8	50	10°
SN-2M	9.5	6	9	53	13°
SN-4M	12.7	6	12	57	28°
SN-6M	16	6	19	63	18°
SN-7M	19	6	16	60	30°

*d:交叉紋(標準品)

*s:單斜紋(訂制品)

*nf:鋁質及銅質用(僅提供6mm柄)

SM圓錐型

Cone Shape



d s

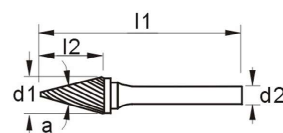

訂購編號 Order No.	Cutting Dia	Shank Dia	Length of Cut	Overall Length	Angle
	d1 mm	d2 mm	l2 mm	l1 mm	a
SM-41M	3	3	8.9	38	12°
SM-42M	3	3	11	38	14°
SM-43M	3	3	16	38	7°
SM-51M	6	3	12.7	51	22°
SM-53M	5	3	13	39	16°
SM-1M	6	6	12.7	50	22°
SM-2M	6	6	19	50	14°
SM-3M	6	6	25	50	10°
SM-4M	9.5	6	16	63	28°
SM-5M	12.7	6	22	69	28°
SM-6M	16	6	25	73	31°

*d:double cut(standard)

*s:single cut(custom made)

*nf:nonferrous(only available for 6mm shank)

SE蛋型
Oval Shape

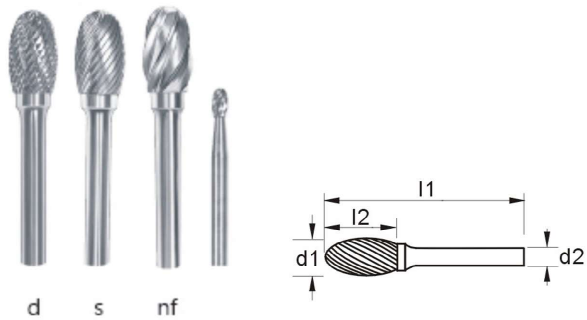

訂購編號 Order No.	Cutting Dia	Shank Dia	Length of Cut	Overall Length
	d1 mm	d2 mm	l2 mm	l1 mm
SE-41M	3	3	5.5	38
SE-51M	6.3	3	9.5	47
SE-53M	5	3	7.1	38
SE-1M	6	6	9.5	50
SE-3M	9.5	6	16	60
SE-5M	12.7	6	22	66
SE-6M	16	6	25	69
SE-7M	19	6	25	69

SF桃型
Tree Shape

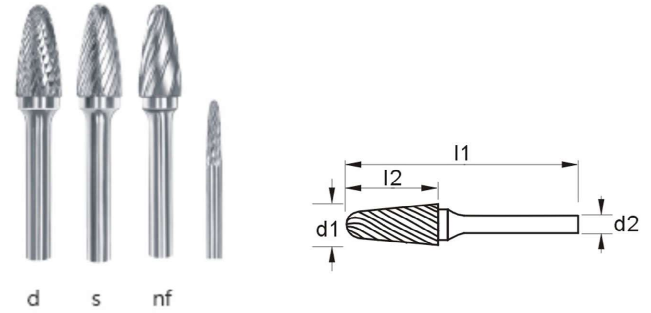

訂購編號 Order No.	Cutting Dia	Shank Dia	Length of Cut	Overall Length
	d1 mm	d2 mm	l2 mm	l1 mm
SF-41M	3	3	6	38
SF-42M	3	3	12.7	38
SF-51M	6.3	3	12.7	56
SF-53M	5	3	12.7	38
SF-14M	19	6	32	76
SF-15M	19	6	38	82
SF-1M	6	6	16	50
SF-3M	9.5	6	19	63
SF-5M	12.7	6	25	69
SF-6M	16	6	25	69
SF-7M	19	6	25	69

SG桃尖型
Tree Shape Pointed End

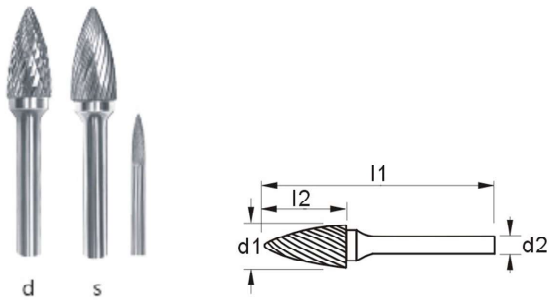

訂購編號 Order No.	Cutting Dia	Shank Dia	Length of Cut	Overall Length
	d1 mm	d2 mm	l2 mm	l1 mm
SG-41M	3	3	6	38
SG-43M	3	3	10	38
SG-44M	3	3	12	38
SG-51M	6.3	3	12	50
SG-53M	5	3	13	38
SG-1M	6	6	16	50
SG-2M	8	6	19	63
SG-3M	9.5	6	19	63
SG-5M	12.7	6	25	69
SG-6M	16	6	25	69
SG-7M	19	6	25	69
SC-15M	19	6	38	82

SH火焰型
Flame Shape

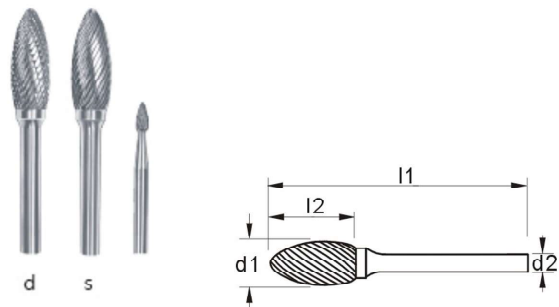

訂購編號 Order No.	Cutting Dia	Shank Dia	Length of Cut	Overall Length
	d1 mm	d2 mm	l2 mm	l1 mm
SH-41M	3	3	6.3	38
SH-53M	5	3	9.5	38
SH-1M	6	6	16	50
SH-2M	8	6	19	63
SH-5M	12.7	6	32	76
SH-6M	16	6	36	80
SH-7M	19	6	41	85

*d:交叉紋(標準品)
*s:單斜紋(訂制品)
*nf:鋁質及銅質用(僅提供6mm柄)

*d:double cut(standard)
*s:single cut(custom made)
*nf:nonferrous(only available for 6mm shank)

棕刷系列 Brush Series

猪毛棕刷 BRISTLE BRUSHES

								
尺寸形狀Size 訂購編號Order No.	5D X 6T ABB-A5	6D X 8T ABB-A6	8D X 10T ABB-A8	20D X 2T ABB-T20	25D X 2T ABB-T25	30D X 2T ABB-T30	10D X 7T ABB-F10	15D X 8T ABB-F15

銅綫刷 CUPPER WIRE BRUSHES

								
尺寸形狀Size 訂購編號Order No.	5D X 6T ABC-A5	6D X 8T ABC-A6	8D X 10T ABC-A8	20D X 2T ABC-T20	25D X 2T ABC-T25	30D X 2T ABC-T30	10D X 7T ABC-F10	15D X 8T ABC-F15

馬毛棕刷 HORSE BRISTLE BRUSHES

								
尺寸形狀Size 訂購編號Order No.	5D X 6T ABH-A5	6D X 8T ABH-A6	8D X 10T ABH-A8	20D X 2T ABH-T20	25D X 2T ABH-T25	30D X 2T ABH-T30	10D X 7T ABH-F10	15D X 8T ABH-F15

不銹鋼刷 STAINLESS STEEL WIRE BRUSHES

								
尺寸形狀Size 訂購編號Order No.	5D X 6T ABS-A5	6D X 8T ABS-A6	8D X 10T ABS-A8	20D X 2T ABS-T20	25D X 2T ABS-T25	30D X 2T ABS-T30	10D X 7T ABS-F10	15D X 8T ABS-F15

羊毛棕刷 WOOL BRUSHES

								
尺寸形狀Size 訂購編號Order No.	5D X 6T ABW-A5	6D X 8T ABW-A6	8D X 10T ABW-A8	20D X 2T ABW-T20	25D X 2T ABW-T25	30D X 2T ABW-T30	10D X 7T ABW-F10	15D X 8T ABW-F15

合金鋼砂磨料，鋒利耐磨，鋼制的柄軸不易彎曲，適用於工具與模具業等。
 Aluminum Oxide Grinding Ping made by PA abrasive.it is high efficiency long tool life
 make your work effective.

粒度: #120

Grit: #120

標準柄徑: 3mm 柄

Standard: 3mm Shanks

尺寸形狀

Shape

訂購編號

Order No.

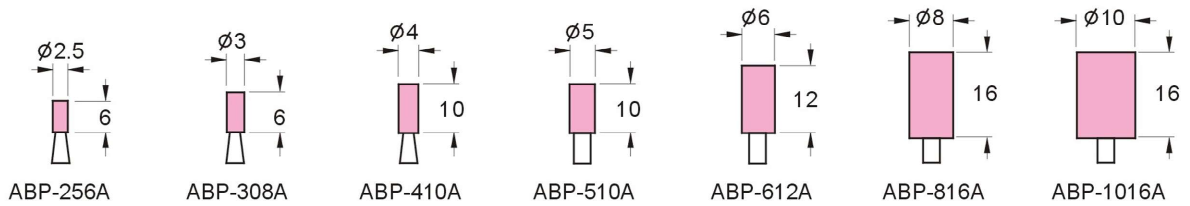

尺寸形狀

Shape

訂購編號

Order No.

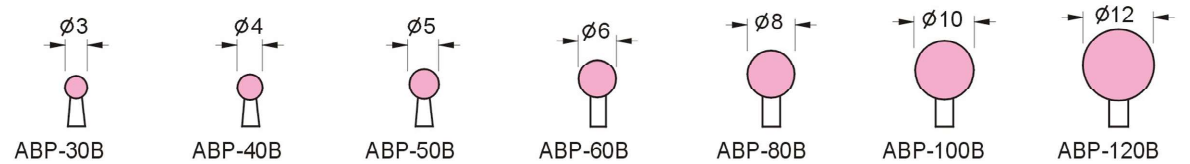

尺寸形狀

Shape

訂購編號

Order No.

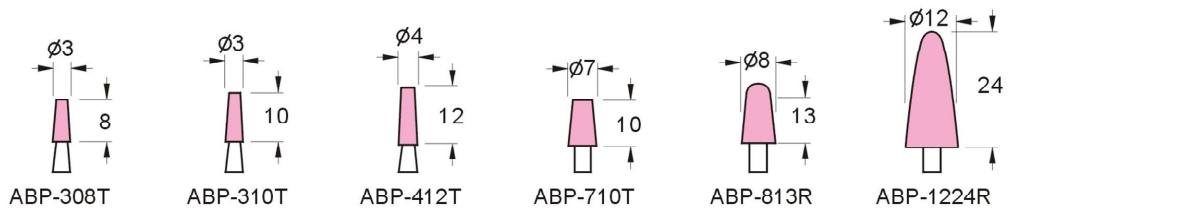

尺寸形狀

Shape

訂購編號

Order No.

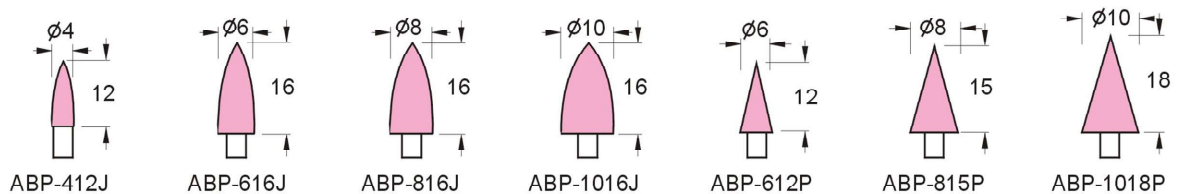

尺寸形狀

Shape

訂購編號

Order No.

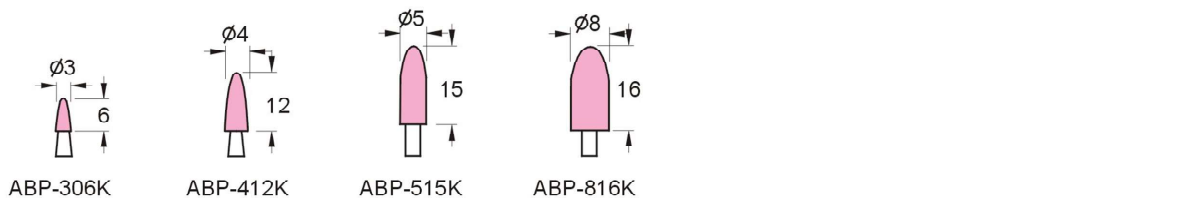

尺寸形狀

Shape

訂購編號

Order No.

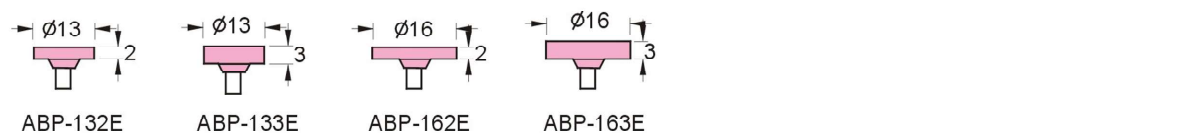

鑽石工具系列 Diamond File Series

DPC

鑽石砂布 Diamond Foil



鑽石砂布是以銅箔為基材，電著上一層鑽石粉，鑽石磨料布滿整個銅箔表面。其特色為有較長之工具壽命，並可以用刀片自行裁減成所需尺寸及形狀，粘貼于各種工具上，成為您所需的自制工具。

其優異的切削效果及多種粒度可供選擇，適合各種模具、鎢鋼、硬陶瓷、石材、玻璃等之研磨及拋光。

Diamond powders are fully sprayed on the surface of copper foil, this features in longer tool life, Fast cutting or polishing on hard steels of tungsten carbides, stones, glass and hard ceramics... etc.

Foil can also be glued to different sized tools and cut to size applied to flexible, adhesive back sheet.

粒度及訂購編號 Grit & Order No.

尺寸 Size	#120	#150	#200	#300	#400	#600	#800	#1200	#1800
50x100mm	DPC-2012	DPC-2015	DPC-2020	DPC-2030	DPC-2040	DPC-2060	DPC-2080	DPC-2120	DPC-2180
100x100mm	DPC-3012	DPC-3015	DPC-3020	DPC-3030	DPC-3040	DPC-3060	DPC-3080	DPC-3120	DPC-3180

鑽石銼刀系列

SP-FLO

德國超微粒光學拋光布 Micro-polierleinen (Made in Germany)

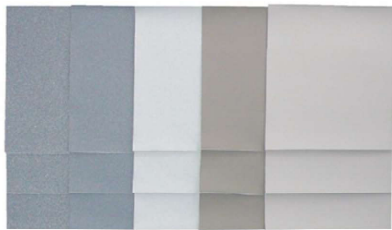

獲得專利的德國超微粒光學拋光布是超精細研磨的最佳選擇。超微粒光學拋光布可應用在不同的材質，如金屬、木材、壓克力、塑料、和玻璃...等。目前美國NASA也將超微粒拋光布使用拋光飛機的側窗。

MICRO-POLIERLEINEN designed for metallographic Applications to fine grind a wide variety latex additive in the cloth. This combination resists water penetration, creating a durable, long-lasting polishing cloth. It is suitable for all kinds of material, like metal, wood, acrylic, plastic, glass... And so forth.

粒度 Grit	尺寸 Size	
	14 x 15cm (3pcs / set)	15cm x 15.2 meters
#1500	SP-FLO-1415-01500-S	SP-FLO-15015-01500
#1800	SP-FLO-1415-01800-S	SP-FLO-15015-01800
#2400	SP-FLO-1415-02400-S	SP-FLO-15015-02400
#3200	SP-FLO-1415-03200-S	SP-FLO-15015-03200
#4000	SP-FLO-1415-04000-S	SP-FLO-15015-04000
#6000	SP-FLO-1415-06000-S	SP-FLO-15015-06000
#8000	SP-FLO-1415-08000-S	SP-FLO-15015-08000
#12000	SP-FLO-1415-12000-S	SP-FLO-15015-12000

產品特點：光學產業使用，顆粒細緻，適合鏡面研磨使用。
Feature: It is with micro grain for mirror polishing, especially for optical industry.

ABL 牛皮彈性帶柄砂輪 Cow Leather Elastic Grinding Pins

牛皮彈性帶柄砂輪

粒度: #100

用途: 一般金屬拋光

COW LEATHER ELASTIC GRINDING PINS

Grit:#100

Application:For Metal Polishing



牛皮輪訂購編號	外徑x厚度x柄徑
Cow Leather Elastic Order No.	OD x Thickness x Shank
ABL-03123	3x12x3mm
ABL-04133	4x13x3mm
ABL-05163	5x16x3mm
ABL-06173	6x17x3mm
ABL-08203	8x20x3mm
ABL-10203	10x20x3mm
ABL-13203	13x20x3mm
ABL-22043	22x4x3mm
ABL-13206	13x20x6mm
ABL-15256	15x25x6mm
ABL-20256	20x25x6mm
ABL-25256	25x25x6mm
ABL-38106	38x10x6mm

ABR 海綿彈性帶柄砂輪 Sponge Elastic Grinding Pins

海綿彈性帶柄砂輪

粒度: #120

用途: 鋁合金及鐵拋光

SPONGE ELASTIC GRINDING PINS

Grit:#120

Application:For Aluminum Alloy and Iron Polishing



海綿輪訂購編號	外徑x厚度x柄徑
Sponge Elastic Order No.	OD x Thickness x Shank
ABR-03123	3x12x3mm
ABR-04133	4x13x3mm
ABR-05163	5x16x3mm
ABR-06173	6x17x3mm
ABR-08203	8x20x3mm
ABR-10203	10x20x3mm
ABR-13203	13x20x3mm
ABR-22043	22x4x3mm
ABR-13206	13x20x6mm
ABR-15256	15x25x6mm
ABR-20256	20x25x6mm
ABR-25256	25x25x6mm
ABR-38106	38x10x6mm

鑽石工具系列 Diamond File Series

ABR-CM 日本制大和海綿輪 Daiwa Rabin(Made in Japan)

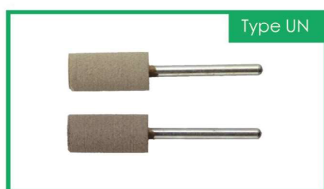
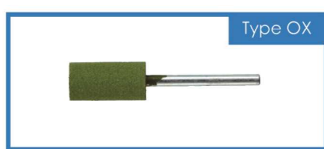
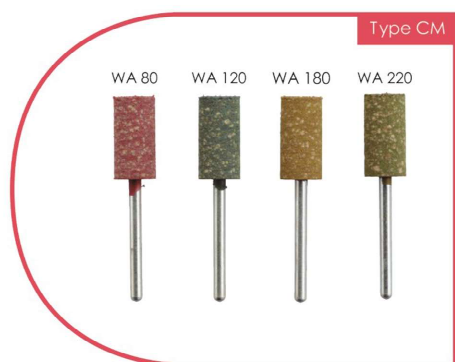

尺寸		
Diameter (D)	Length (L)	Shank Diameter(d)
4	13	3
5	15	3
6	17	3
8	20	3
10	20	3
13	20	3
15	17	3
20	25	6
25	25	6

訂購範例: $\frac{\text{ABR-CM}}{\text{型號}} \frac{0413}{\text{尺寸}} \frac{\text{WA}}{\text{磨料}} \frac{80}{\text{粒度}}$

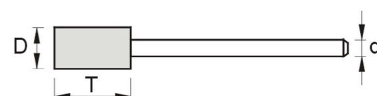

鑽石銼刀系列

日本[大和磨石]可均勻的拋光物件而不會留下任何刮傷，進而減少加工步驟并改善物件表面粗糙度。因擁有不會造成刮傷與碎屑堵塞的特性，可于鋁制鑄模上進行持續性的加工，無需經歷多次研磨加工過程進而減低工作時程，另可針對各種材料、各式尺寸和形狀來提供最適合去毛邊之磨料。[大和海綿輪]擁有鋒利的研磨特性，因而可以去除硬度較高的工件(如硬度近似HRC60之SKD、HSS、和FCD)上之毛邊或刮痕。它甚至可以在很薄的工作物上研磨，也可以輕易去除白鐵上之焊接痕。

Type CM

此磨料為大和長期暢銷的產品。優異的切削及其自身的拋光彈性。CM結合劑的特征主要用于壓鑄模和不銹鋼等多種的模具。

研磨粒: WA-CM

粒度: 80, 120, 180, 220, 320

Type OX

OX主要適用於精加工拋光時使用。另外它可輕易的清除工件上的生銹并維持模具尺寸，幾乎不損壞工件表面。OX也適合拋光黃金、銅和其他有色金屬。發絲處理的磨粒，磨粒含量比，橡膠的質量和硬度是提供一個均衡的磨料組合。

研磨粒: WA,A,C,GC,鑽石磨粒

粒度: #120,180,220,320,400,600,800,1000,1500,3000

Type UN

UN擁有比CM更高的硬度，適用於倒角、去毛刺、對付硬質材料鋒利的毛刺以及磨料頭部不易變形的特性。此外，它是能有效維持加工工件的形狀，使成形工件不易變形。對於去除細毛刺或加工精度部分效果尤佳。

研磨粒: WA,A,C,GC

粒度: #120,180,220,320,400,600,

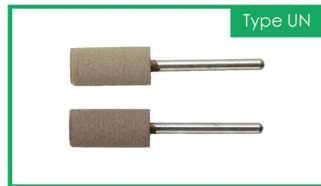
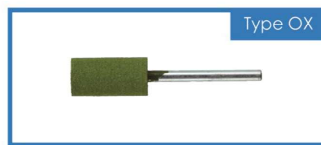
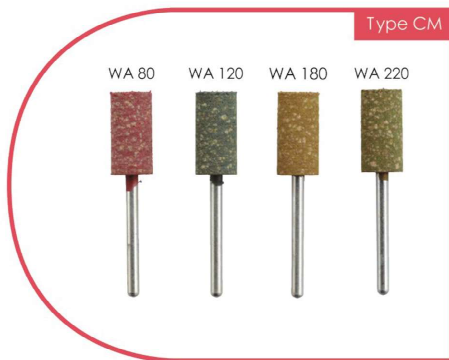

尺寸		
Diameter (D)	Length (L)	Shank Diameter(d)
4	13	3
5	15	3
6	17	3
8	20	3
10	20	3
13	20	3
15	17	3
20	25	6
25	25	6

Order Ex:

ABR-CM	0413	WA	80
Model No.	Size	Bonding	Grit

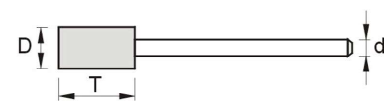

DAIWA RABIN has sharpness enough for grinding and removing tooling marks and burrs even high hardened work materials(such as SKD,HSS and FCD that are around HRC60).It is also able to remove weld bead of stainless of stainless steel and make a polished surface when it is thin.

Type CM

It is a long-selling product. The CM type is sharp and excellent in polishing with its own elasticity.The characterized also by versatility applicable to aluminum die casting and stainless steel including molds.

Abrasive Grain:WA-CM grain(Our original abrasive grain has been used.)

Available Grit size:#60,80,120,180,220,320

Type OX

OX type for fine polishing.It removes rust and maintains molds,without damorkpieces..OX is proper for polishing gold,copper and other non-ferrous metals.A well balanced combination of abrasive grain,abrasive grain concentration,rubber quality and hardness is available for hairline processing.

Abrasive Grain:WA,A,C,GC,Diamond abrasive

Available Grit size:#120,180,220,320,400,600,800,1000,1500,3000

Type UN

It is harder than Type CM and suitable for corner chamfering,de-burring sharp burrs and hard materials,it won't lose its shape easily.In addition,it is efficient when you do not want to lose working form of work piece.It is utiliz able for removing fine burrs from and finishing precision part,too.

Abrasive Grain:WA,A,C,GC

Available Grit size:#120,180,220,320,400,600,

鑽石工具系列 Diamond File Series

CMP/KMP

GS鑽石膏 GS Diamond Compound



鑽石膏適用於模具、超硬合金、陶瓷、寶石...等等之精密拋光及鏡面加工。
 本產品依照客戶的需求分為兩種等級，標準品針對寶石加工、中硬度模具...等使用者。如需使用在高硬度模具時，建議您使用較高鑽石等級的鑽石膏。
 The diamond compound is using for polishing all kinds of mold, ceramic, jewel and so forth operation.
 We divide our quality into 2 levels. For normal jewel and mold makers, we suggest you using standard quality and for professional mold makers, the high quality will be satisfied with your target.

鑽石銼刀系列

高品質代號 Order No.	標準品代號 Order No.	粒度	包裝容量	顆粒尺寸	用途
High Quality	Standard	#Grit	Package(g)	Micron Range(u)	Function
CMP-28000	KMP-28000	28000	5g裝	0.5	鏡面加工用 Mirrorlike Polishing
CMP-14000	KMP-14000	14000		1	
CMP-08000	KMP-08000	8000		3	
CMP-05000	KMP-05000	5000		4.5	精加工用 Fine Polishing
CMP-03000	KMP-03000	3000		6	
CMP-02000	KMP-02000	2000		8	
CMP-01800	KMP-01800	1800		9	
CMP-01500	KMP-01500	1500		13	普通加工 Normal Polishing
CMP-01200	KMP-01200	1200		15	
CMP-01000	KMP-01000	1000		17.5	
CMP-00800	KMP-00800	800		25	
CMP-00600	KMP-00600	600		35	
CMP-00400	KMP-00400	400		50	粗加工用 Rough Polishing
CMP-00200	KMP-00200	200		90	



- 無段式轉速液晶顯示操控裝置。
- 50,000轉超高轉速，并可自由設定順時針及逆時針旋轉。
- 7.8N.cm超高扭力旋轉手機，在低轉速下仍可以有高扭力表現。
- 本機可自我偵測錯誤顯示及工作記憶模式功能。
- 隨機附贈腳踏板開關，使您操控更容易。
- 液晶時鐘顯示面板。

GLV500CB (Control Box)

- AC 110V 60Hz
- AC 220V 50Hz
- 5A Fuse for 100v, 2A Fuse for 220V
- Weight: 2.5kg
- W(寬): 96 D(長): 207 H(高): 182
- Non stage speed system and Liquid crystal surface version.
- Strong torque at low speed with Hand/Foot speed control system.
- Right & Left turning ability.
- 50,000 rpm high-powered brushless Handpiece with super-slim & light design.
- Self-diagnosis error display, Work memory storage function.
- Digital watch.

GLV500HP (Hand Piece)

- Non Load RPM: 50,000
- Max Torque: 7.8N.cm
- Output: 230W

DIMENSION

- Weight: 245g
- L: 171
- L1: 78
- L2: 93
- D: 27
- D1: 18

備注：夾頭另有 $\varnothing 1.6/\varnothing 2.34/\varnothing 3.175$ 可供選擇

Remark: Collet $\varnothing 1.6/\varnothing 2.34/\varnothing 3.175$ (optional)

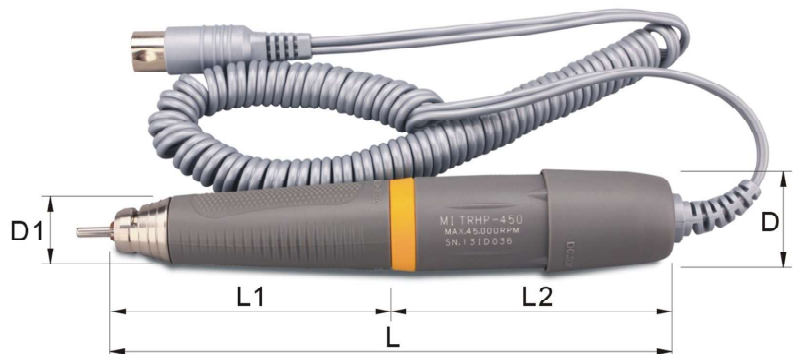

訂購範例 Order Ex GLV500-110(110V) GLV500-220(220V)

電動研磨機 Electric Rotary Grind

GLV450 45,000轉電動研磨機 45,000R.P.M. Electric Rotary Grinder



GLV450HP

- Non Load Rpm: 45,000
- Max Torque: 450 gf.cm

GLV450CB

- AC 100~200V 50/60Hz
- Fuse: 3A
- Weight: 1.8kg
- W: 130 L: 152 H: 103

備注: 夾頭另有 $\varnothing 1.6/\varnothing 2.34/\varnothing 3.175$ 可供選擇
Remark: Collet $\varnothing 1.6/\varnothing 2.34/\varnothing 3.175$ (option)

- 無段式轉速操控裝置, 您可自由調整從0到45,000rpm。
- 自動超載負荷偵測裝置及反饋系統, 可延長機身壽命。
- 本機可自由設定順時針及逆時針旋轉。
- 加大型腳踏開關, 使您操控更容易。
- 超高扭力旋轉手機, 切削性效率提升50%
- Non stage speed system.
- Hand / Foot speed control system.
- Right & Left turning ability.
- 45,000 rpm high-powered carbon brush motor.

DIMENSION

- Weight: 240g
- L: 156.8
- L1: 77.8
- L2: 79
- D: 26.8
- D1: 19

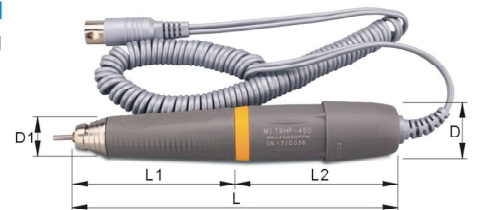

GLV350 35,000轉電動研磨機 35,000R.P.M. Electric Rotary Grinder

GLV350CB

- AC 100~200V 50/60Hz
- Fuse: 3A
- Weight: 1.2kg
- W: 130 L: 150 H: 84

備注: 夾頭另有 $\varnothing 1.6/\varnothing 2.34/\varnothing 3.175$ 可供選擇
Remark: Collet $\varnothing 1.6/\varnothing 2.34/\varnothing 3.175$ (option)

- 無段式轉速操控裝置, 您可自由調整從0到35,000rpm。
- 本機可自由設定順時針及逆時針旋轉。
- 隨機附贈腳踏開關, 操控方式更加多元化。

- Non stage speed system (Well designed to output from zero to 35,000rpm by using non stage speed system).
- Right & left turning ability.

GLV350HP

- Non Load Rpm: 35,000
- Max Torque: 300 gf.cm

DIMENSION

- Weight: 232g
- L: 159
- L1: 74
- L2: 85
- D: 28.2
- D1: 18.9





- 輸入電壓 Power Input : AC110V~AC230V
 - 發振頻率 OSC Frequency : 25KHz~40KHz AUTO SWEEP
 - 消耗功率 Power Output : 45W max
 - 輸出功率範圍 : 5W~35W
Output Power Range
 - 尺寸Size : 150x180x140(WxLxH)
 - 發振電源供應器重量 : 2.4kgs(±0.2kgs)
Power Supply Weight
- ※可選配電動旋轉手機GLV450HP

氣動工具(日系) Air Grinder (Japanese Series)

70000 TLL-07 往複式氣動超音波機 Reciprocating Ultrasonic Air Grinder

往復行程/Stroke: 0.7mm
轉速/Free speed at 90psi: RPM22, 000
空氣消耗量/Air consumption: 46nl/min
尺寸/Dimensions: Ø28x196L
重量/Weight: 166g



70001 TLL-03 往複式氣動超音波機 Reciprocating Ultrasonic Air Grinder

往復行程/Stroke: 0.3mm
轉速/Free speed at 90psi: RPM55, 000
空氣消耗量/Air consumption: 125nl/min
尺寸/Dimensions: Ø28x196L
重量/Weight: 166g



70002 TLL-1.2 往複式氣動超音波機 Reciprocating Ultrasonic Air Grinder

往復行程/Stroke: 1.2mm
轉速/Free speed at 90psi: RPM15, 000
空氣消耗量/Air consumption: 45nl/min
尺寸/Dimensions: Ø28x196L
重量/Weight: 166g



70003 TLL-0.15 往複式氣動超音波機 Reciprocating Ultrasonic Air Grinder

往復行程/Stroke: 1.5mm
轉速/Free speed at 90psi: RPM55, 000
空氣消耗量/Air consumption: 125nl/min
尺寸/Dimensions: Ø28x196L
重量/Weight: 166g



70004 FX-A3.0 高速筆刻機 High Speed Straight Air Grinder

轉速/Free speed at 90psi: RPM65, 000
空氣消耗量/Air consumption: 120nl/min
尺寸/Dimensions: Ø22.5x150L
重量/Weight: 78g



70005

MSG-3BSN

精密型刻磨機

High Speed Straight Air Grinder

轉速/Free speed at 90psi: RPM65, 000
 空氣消耗量/Air consumption: 120nl/min
 尺寸/Dimensions: Ø17x143L
 重量/Weight: 130g



70006

MAG-123N

平面研磨機

Surface Air Grinder (120°)

轉速/Free speed at 90psi: RPM23, 500
 空氣消耗量/Air consumption: 120nl/min
 尺寸/Dimensions: Ø17x50x123L
 重量/Weight: 175g



70007

MAG-093N

平面研磨機

Surface Air Grinder (90°)

轉速/Free speed at 90psi: RPM23, 500
 空氣消耗量/Air consumption: 120nl/min
 尺寸/Dimensions: Ø17x44x118L
 重量/Weight: 160g



70008

MAG-121N

內孔研磨機

Inner Hole Air Grinder (120°)

轉速/Free speed at 90psi: RPM52, 500
 空氣消耗量/Air consumption: 120nl/min
 尺寸/Dimensions: Ø17x78x107L
 重量/Weight: 140g



70009

MAG-122N

內孔研磨機

Inner Hole Air Grinder (90°)

轉速/Free speed at 90psi: RPM35, 000
 空氣消耗量/Air consumption: 120nl/min
 尺寸/Dimensions: Ø17x55x104L
 重量/Weight: 140g



PAIR GRINDER
 氣動工具

氣動工具 Air Grinder

70010

AIR-917/913

超高速來回研磨機 Ultrahigh Speed Grinding Machine

編號/Order no.: AIR-917或AIR-913
往復行程/Stroke: 0.7或0.3mm
轉速/Free speed at 90psi: RPM35,000/40,000
夾頭/Collet chuck: $\varnothing 1, \varnothing 3$ mm
尺寸/Dimensions: $\varnothing 29 \times 228$ L
重量/Weight: 170g
使用方法: 尼龍纖維外蓋超高速去毛邊

**70011**

AIR-947/943

輕渦輪長時間作業用 Turbine Long Time Operation

編號/Order no.: AIR-947或AIR-943
往復行程/Stroke: 0.7或0.3mm
轉速/Free speed at 90psi: RPM35,000/40,000
夾頭/Collet chuck: $\varnothing 1, \varnothing 3$ mm
尺寸/Dimensions: $\varnothing 26 \times 217$ L
重量/Weight: 181g
使用方法: 輕, 適合女性長時間作業用

**70012**

AIR-951

輕量高速筆刻機 High Speed Air Grinder

轉速/Free speed at 90psi: RPM70,000
夾頭/Collet chuck: $\varnothing 3, \varnothing 1/8, \varnothing 2.4$ mm
尺寸/Dimensions: $\varnothing 18 \times 150$ L
重量/Weight: 82g
使用方法: 輕, 可長時間作業日本NSK培林

**70013**

AIR-953

雙接型高速筆刻機 High Speed Air Grinder

轉速/Free speed at 90psi: RPM80,000 4叶片
夾頭/Collet chuck: $\varnothing 3$ mm
尺寸/Dimensions: $\varnothing 18 \times 162$ L
重量/Weight: 110g
使用方法: 馬達與研磨頭各分美國杜邦葉片

**70014**

AIR-954

高速筆刻機 High Speed Air Grinder

轉速/Free speed at 90psi: RPM80,000
夾頭/Collet chuck: $\varnothing 3$ mm
尺寸/Dimensions: $\varnothing 17 \times 155$ L
重量/Weight: 125g
使用方法: 美國杜邦4葉片馬達、研磨分開

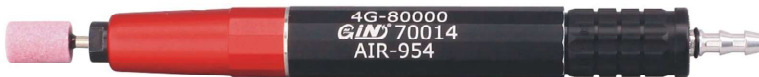

70015
AIR-952
高速型氣動研磨機 High Speed Air Grinder

轉速/Free speed at 90 psi: RPM70,000

 夾頭/Collet chuck: $\varnothing 3, \varnothing 1/8, \varnothing 2.4\text{mm}$

 尺寸/Dimensions: $\varnothing 18 \times 135\text{L}$

重量/Weight: 118g

使用方法: 輕, 可長時間作業日本NSK培林

70016
AIR-965
平面研磨機 45° Angle Air Grinder

轉速/Free speed at 90 psi: RPM35,000

 夾頭/Collet chuck: $\varnothing 30\text{mm}$

 尺寸/Dimensions: $\varnothing 30 \times 168\text{L}$

重量/Weight: 218g

70017
AIR-967
平面研磨機 Surface Air Grinder (90°)

轉速/Free speed at 90 psi: RPM35,000

 夾頭/Collet chuck: $\varnothing 30\text{mm}$

 尺寸/Dimensions: $\varnothing 30 \times 158\text{L}$

重量/Weight: 200g

70018
AIR-A965
內孔研磨機 Inner Hole Air Griner (45°)

轉速/Free speed at 90 psi: RPM35,000

 夾頭/Collet chuck: $\varnothing 30\text{mm}$

 尺寸/Dimensions: $\varnothing 30 \times 168\text{L}$

重量/Weight: 218g

70019
AIR-A967
內孔研磨機 Inner Hole Air Griner (90°)

轉速/Free speed at 90 psi: RPM35,000

 夾頭/Collet chuck: $\varnothing 3, \varnothing 30\text{mm}$

 尺寸/Dimensions: $\varnothing 30 \times 158\text{L}$

重量/Weight: 200g



氣動工具 Air Grinder

70020

A971

0.3馬力強力研磨機(加長型) 0.3 HP Air Grinder

轉速/Free speed at 90psi: RPM28,000
夾頭/Collet chuck: $\varnothing 3, \varnothing 6\text{mm}$
尺寸/Dimensions: $\varnothing 32 \times 287\text{L}$
重量/Weight: 591g



70021

A972

平面左右研磨機 Swing Stroke Air Grinder

往復行程/Stroke: 1mm(swing)
轉速/Free speed at 90psi: RPM28,000
夾頭/Collet chuck: 白鋼片x2
尺寸/Dimensions: $\varnothing 32 \times 205\text{L}$
重量/Weight: 525g



70022

A973

砂輪研磨機 Grinding Wheel Grinder

轉速/Free speed at 90psi: RPM28,000
夾頭/Collet chuck: $\varnothing 3, \varnothing 6\text{mm}$
尺寸/Dimensions: $\varnothing 32 \times 165\text{L}$
重量/Weight: 372g



70023

A974

左右研磨機 Swing Air Lapper

往復行程/Stroke: 1mm(swing)
轉速/Free speed at 90psi: RPM28,000
夾頭/Collet chuck: $\varnothing 6\text{mm}$
尺寸/Dimensions: $\varnothing 32 \times 180\text{L}$
重量/Weight: 575g



氣動工具示意 Air Grinding Demostration



Please refer to GinTech Mold Components, for more info www.ginchan.com



銼刀
Diamond Files



鑽石磨棒
Diamond Burrs



鎢鋼滾磨刀
Solid Carbide Page



帶柄砂輪
Grinding Pins Page

氣動工具
PAIR GRINDER



精展精密科技股份有限公司(總公司)
GIN TECH PRECISION CO., LTD.

238001台灣新北市樹林區保安街一段341巷7號

Address: No 7, Lane 341, Sec. 1, Bau An Street, Shulin Dist.,
New Taipei City, 238001, Taiwan

TEL: 886-2-2681-8596 (Rep.)

FAX: 886-2-2681-8516

Email: Sales@ginchan.com.tw

Web: www.gin-chan.com

東莞美商精展機械五金有限公司
東莞市精展機械五金有限公司
GIN CHAN MACHINERY & HARDWARE CO., LTD.(DONGGUAN)

廣東省東莞市大朗鎮石廈村金沙崗二路27號

Address: No 27, Jinshagang 2nd Road, Shixia Village,
Dalang Town, Dongguan, Guangdong, P.R.China

TEL: 86-769-8318-5858 (Rep.)

FAX: 86-769-8318-5838/8313-5003

Email: Sales@ginchan.com.cn

Web: www.ginchan.com.cn



YouTube



微信扫一扫