

5-axis Self-centring Vise

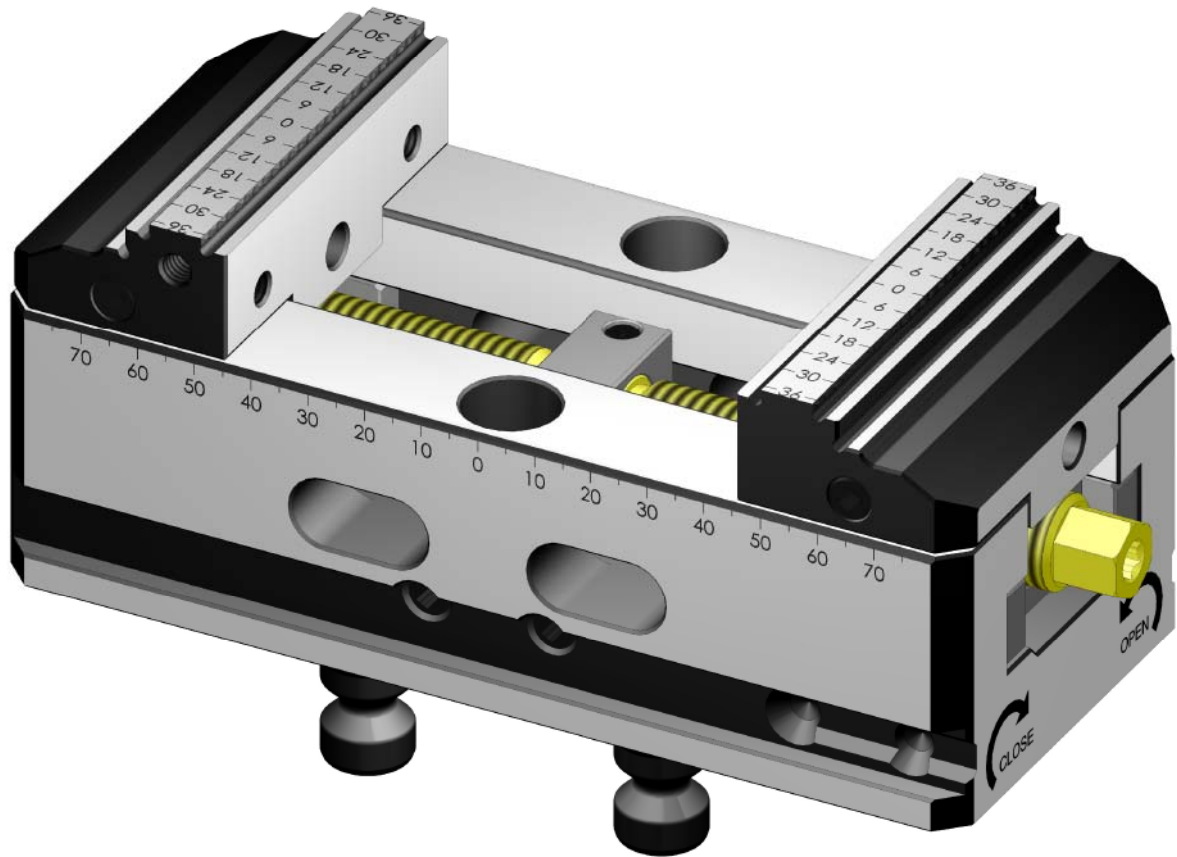

PQV

A01-A20

公司簡介 Introduction

自1988年成立以來，精展精密科技一直致力於提高生產效率和產品質量，以滿足客戶的需求。經過持續創新及改進，無論在產品多樣性或是質量表現上都能讓精展在市場上具有競爭優勢。

精展主要生產磨床、銑床等工具機配件和模具零配件。因客戶的信賴及支持，更因應客戶的工業4.0自動化的需求而推出【模組化並列式虎鉗】、【自定心虎鉗】、【零點快換板】三個系列產品，提供多種加工夾緊解決方案。領先的技術水平，先進的加工設備，優異、穩定的表現深獲客戶贊譽。

[品質、信用、可靠、專業]是精展堅持貫徹的經營理念，我們懷抱貢獻產業的使命，不斷成長茁壯，用前瞻視野洞悉客戶未來需求，期許以多年的專業經驗與突破性的創新動力，提供更高效率、節能的零配件產品，協助客戶開創未來競爭力，精展總是為您想的更多。

GinTech has been striving making improvement on productivity as well as product quality in order to fulfill customer demands. Constantly innovation and improvement to achieve both product variety coverage and quality which gives competitiveness edge in the market.

For industril 4.0 and workholding solutions, Modular Clamping System (MKS), 5-axis Self-centering Vise (PQV) and Zero-Point System (EQS) series are hencedeveloped and introduced. Workholding solutions versatily provide leading edge and steady performance for customers' satisfactory.

Quality, Trust, Reliability, Profession, these are the essence for GinTech management. Embracing the contribution to the industry with constant growth as well as vision for further demand in the market. GinTech always think further ahead in the front.

G.M. /

The logo for GinTech, featuring the word "GinTech" in a stylized, handwritten font with a red underline.

加工設備

- CNC 臥式加工中心機 (300 mm 四方工作盤 x 10座)
- CNC 臥式加工中心機 (400 mm 四方工作盤 x 10座)
- CNC 臥式加工中心機 (400 mm 四方工作盤 x 2座)
- CNC 臥式加工中心機 (400 mm 四方工作盤 x 24座)
- CNC 五面加工中心機 (400 mm 四方工作盤 x 2座)
- CNC 五面加工中心機 (300 mm 四方工作盤 x 10座)
- CNC 五軸同動加工中心機 (150 x 150 mm 盤 x 180座)
- CNC 立式加工中心機 (400 x 800 mm 盤)
- CNC 立式加工中心機 (500 x 1000 mm 盤)
- CNC 四軸車銑複合加工機
- CNC 七軸車銑複合加工機
- CNC 九軸車銑複合加工機
- 立式銑床 (2馬力)
- 立式銑床 (1.5馬力)
- CNC 自動車床
- 手動車床
- 無心磨床
- 外圓磨床
- 桌上型內外圓磨床
- CNC 平面磨床
- 手動平面磨床
- 三軸自動平面磨床
- 自動內孔磨床
- CNC 三軸外圓磨床
- CNC 五軸外圓磨床
- CNC 雙軸內孔磨床

INDEX



PQV 零點定位自定心虎鉗
5-Axis Self-Centering Vise (for EROWA, System-3R)
搭配 EROWA、3R定位使用 A01~A06



PQV 零點定位自定心虎鉗
5-Axis Self-Centering Vise (for Zero-point System)
搭配 96 / 52快換基座使用 A07~A20

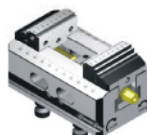

EQS 96 / 52 零點方型快換基座
Zero-Point Plates 96 / 52 B01~B09



EQR 96 / 52 零點圓型快換基座
Zero-Point Plates 96 / 52 B10~B14

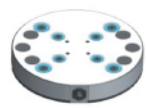

EQP 零點96快換三面基座
Zero-Point Pyramid 96 B15

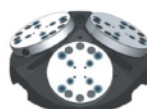

EQT 零點96 / 52雙面轉向快換基座(立管)
Zero-Point Twin Base 96 / 52 B16



EQH 零點96 / 52五軸虎鉗零點加高座
Zero-Point Riser 96 / 52 B17~B18



EQB 零點連接板底座
Zero-Point Adaptor Plate B19



EQE 零點96轉96 / 52快換連接座(加高型)
Zero-Point Riser Adaptor B20



EQA 零點定位校正及其零點配件
Zero-Point Accessories B21~B24



MKS 模組化並列式虎鉗
Modular Clamping System C01~C20

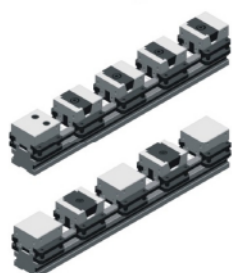

PQV

自定心虎鉗

Self-Centering Vice

PQV100W

M Stainless steel
H HRC50°~52°

特點

- ▶ 鉗口快速更換方向，旋轉180°增大夾持範圍。
- ▶ 根據夾持大小選用兩種鉗口，中間有防塵片防護。
- ▶ 鉗口重複夾持精度0.005mm。
- ▶ 可接並列虎鉗基座，EROWA,SYSTEM-3R系統。

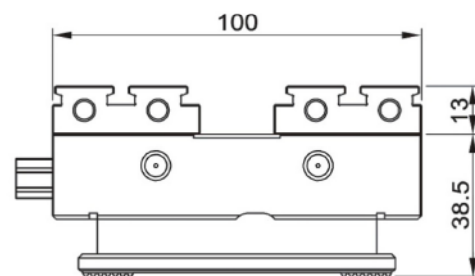
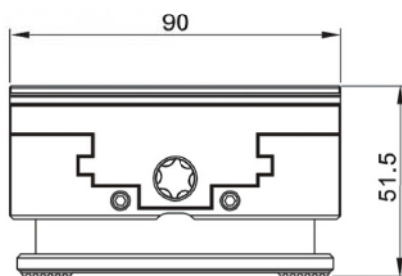
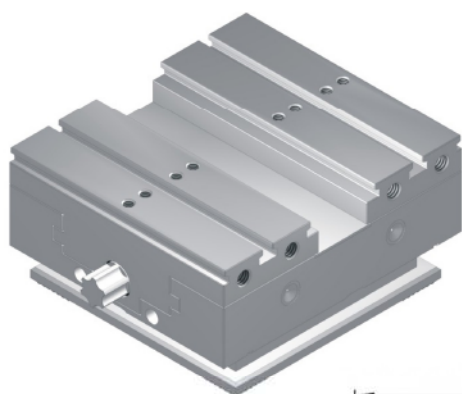
**Features**

- ▶ Quickly change the direction of the jaws and rotate 180° to increase the clamping range.
- ▶ Dust protective cover is included.
- ▶ Clamping repeating accuracy within 0.005mm.
- ▶ Compatible with EROWA & System-3R

可安裝不同鉗口使用(標配大小鉗口各一組)

A02

(Standard large and small jaw sets provided)

大鉗口固定座



小鉗口固定座(使用例1)

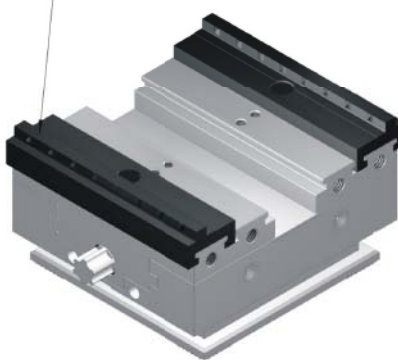

小鉗口固定座(使用例2)

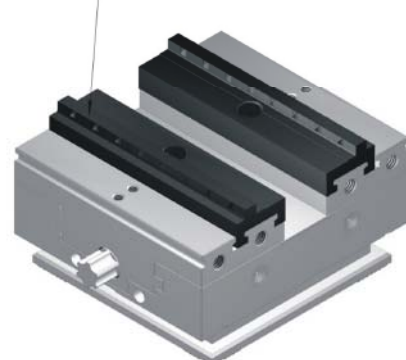

訂購編號 Order No.	型號 Model	描述 Description	重量 N.W.
64850-100W	PQV100W	可接並列虎鉗基座，EROWA,SYSTEM-3R系統。	3.0kg

PQV100W / PQV100WA通用夾爪(鉗口)

Standard Jaw sets

M SKD61 S QPQ HV950°

標配鉗口A
Type A

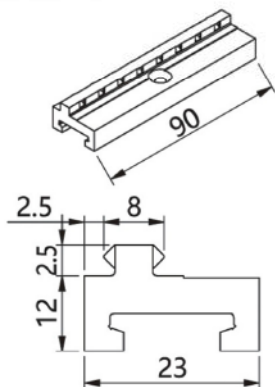

M SKD61 S QPQ HV950°

標配鉗口B
Type B

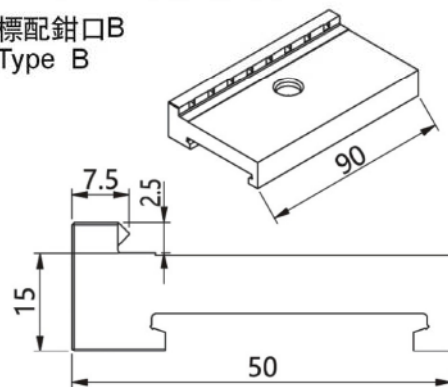

夾持範圍示意Clamping demo

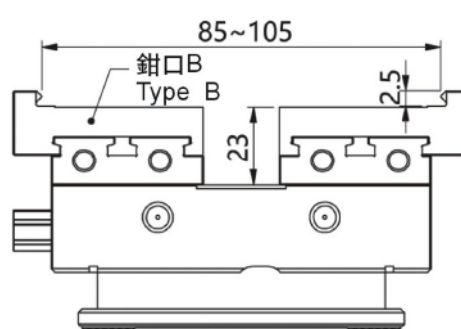
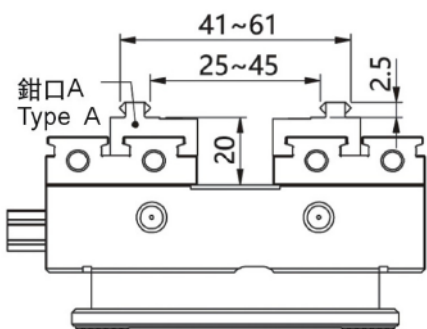
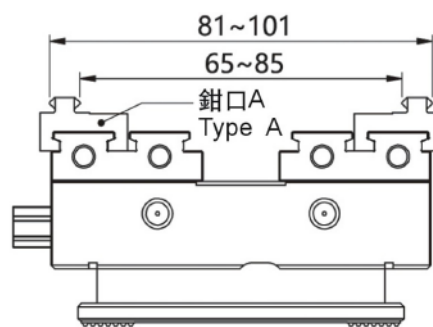
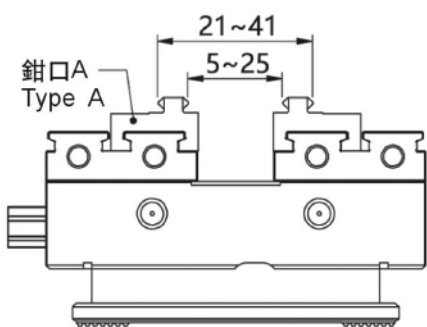
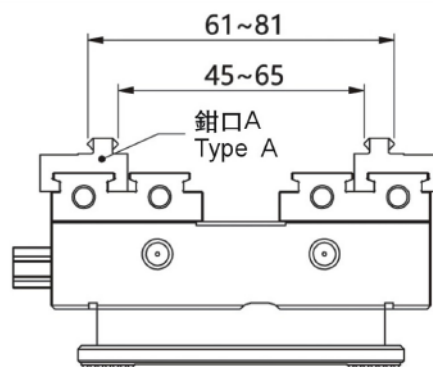
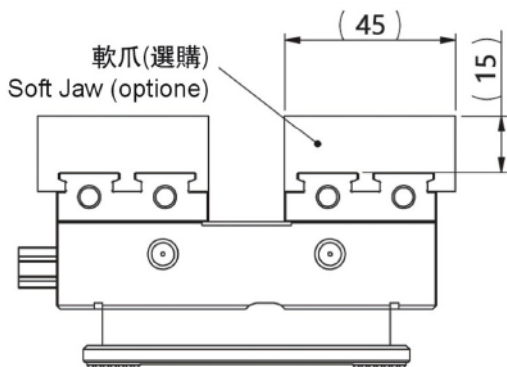

PQV

自定心虎鉗 Self-Centering Vice

PQV100W

多種型式使用 Versatility Application

底部90°雙向齒排結構
可旋轉方向安裝於
並列式虎鉗基座

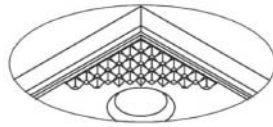

Cross teeth pattern at the bottom
which compatible with MKS system
base on two directions.

400mm基座
橫向夾持可擺放3台
3 vises could be mouted on a 400mm
base.

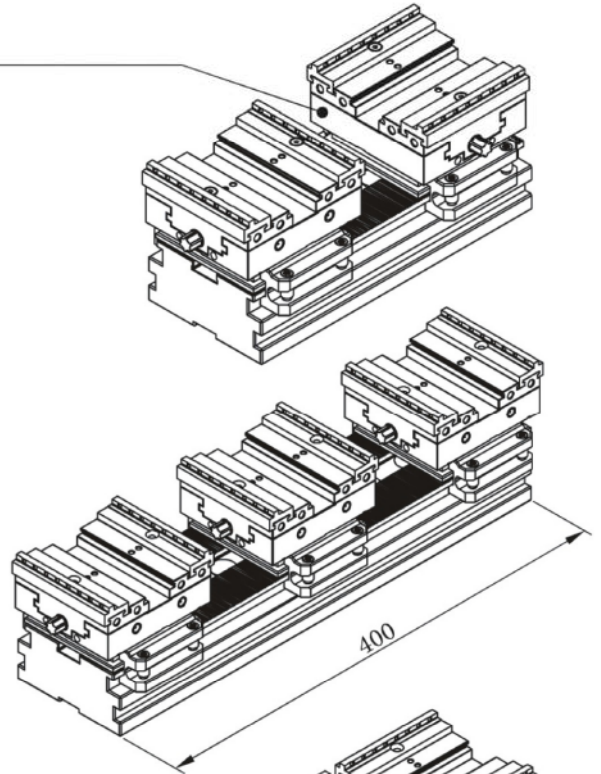

400mm基座
直向夾持可擺放4台
Cross teeth pattern at the bottom
4 vises could be mouted on a 400mm
base.

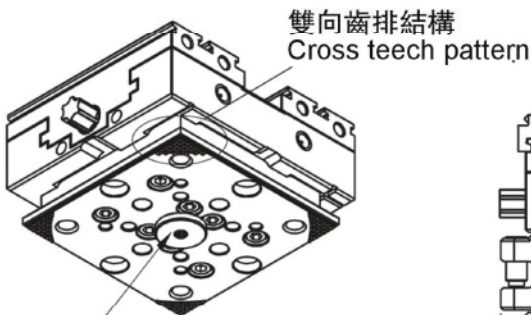
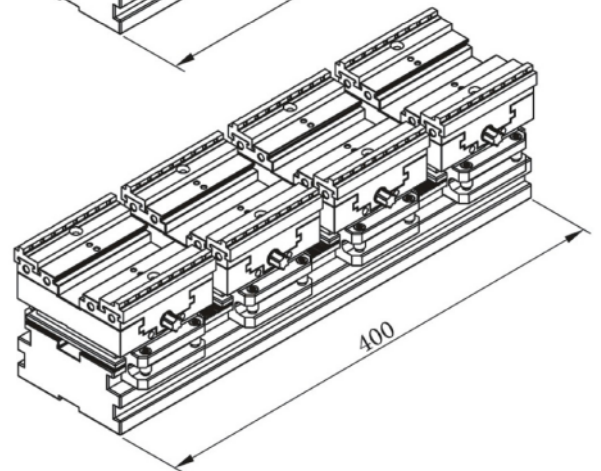

雙向齒排結構
Cross teech pattern

可選購
安裝於並列式虎鉗基座用的定位柱
Optonal centering stub for MKS base

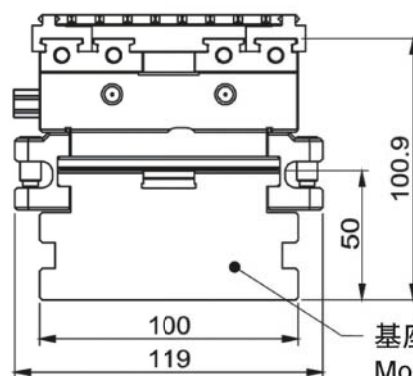

基座長度請參閱 [☞ C13~C15](#)
More info on MKS base length refer to



並搭配K型夾持塊x2件
即可安裝於並列虎鉗基座

PQV

自定心虎鉗 Self-Centering Vice

通用配件 Accessories

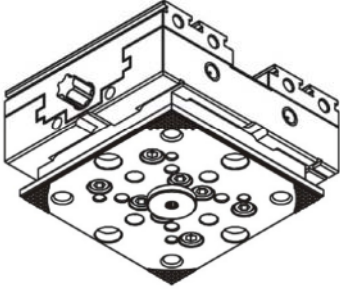

PQQV100W

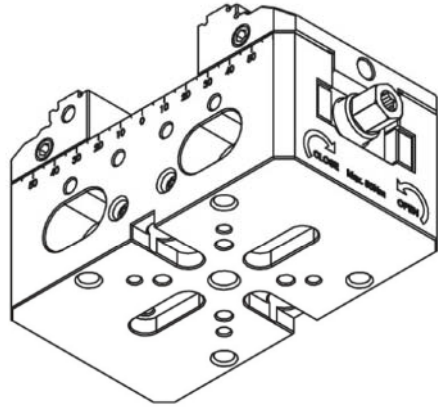

PQQV204V / PQQV305V / PQQV407V

(PQQV204V 無法使用ER-011599-1)

可選購零件Optional accessories:

EROWA: ER-011599或ER-009214定位片Centering plate

SYSTEM-3R: 3R-651.7-P微托盤Macro pallet

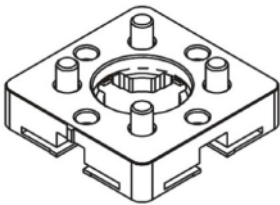

3R-651.7-P

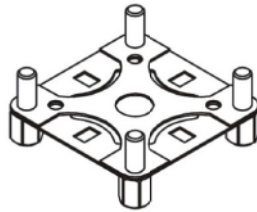

ER-009214-1

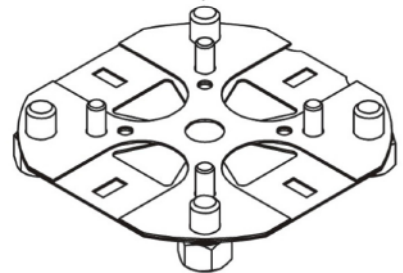

ER-011599-1

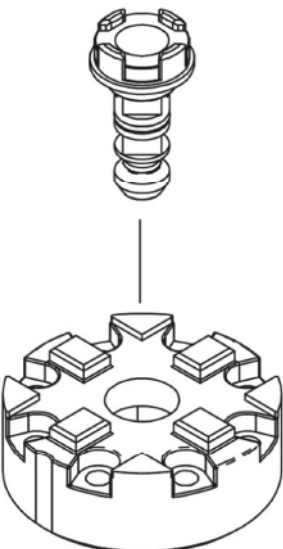

SYSTEM-3R

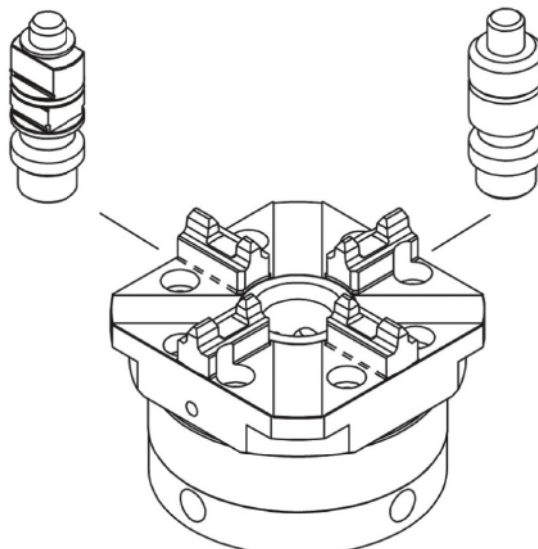

EROWA

PQV

自定心虎鉗

Self-Centering Vise

PQV204VE / 305VE / 407VE

特點

- ▶ 鉗口快速更換方向，旋轉180°增大夾持範圍。
- ▶ 夾爪鉗口和帶動螺母設有角固式結合，能減少夾持上浮量。
- ▶ 鉗口重複夾持精度0.005mm。
- ▶ 單邊夾持端的鉗口，可隨毛胚工件的不平行而擺動，增加毛胚素材夾緊力。
- ▶ 標配EROWA定位板(不含拉桿)。

Features

- ▶ Quickly change the direction of the jaws and rotate 180° to increase the clamping range.
- ▶ Angle lock mechanism between clamping jaws and driven nut reducing lifting while clamping.
- ▶ Clamping repeating accuracy within 0.005mm.
- ▶ Special swing 1.5° design on one side clamping jaw for better gripping when workpiece is non-parallel.
- ▶ Standard with EROWA centering plate. (Spigot not included)

PQV204VE



拉桿 Spigot

PQV305VE



PQV407VE



訂購編號 / Order No.		64850-204VE	64850-305VE	64850-407VE
型號 / Model		PQV204VE	PQV305VE	PQV407VE
本體長度 / Body length	mm	105	130	180
夾持範圍 / Clamping range	mm	0~77	0~102	0~152
鉗口寬度 / Jaw width	mm	54	75	100
鉗口材質 & 硬度 / M & H Jaw		SCM440 HRC53°~55°		
主體材質 & 硬度 / M & H Body		不銹鋼INOX HRC50°~52°	SKS3 HRC50°	SKS3 HRC50°
擰緊力矩 / Tightening torque	Nm	60	70	80
夾緊力 / Clamping force	kN	12	14	16
中心定位精度 / Centring accuracy		0.005		
重量 / Weight	kg	2.3	3.8	6.8

PQV

自定心虎鉗 Self-Centering Vice

PQV204V / 305V / 407V

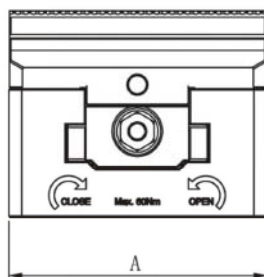
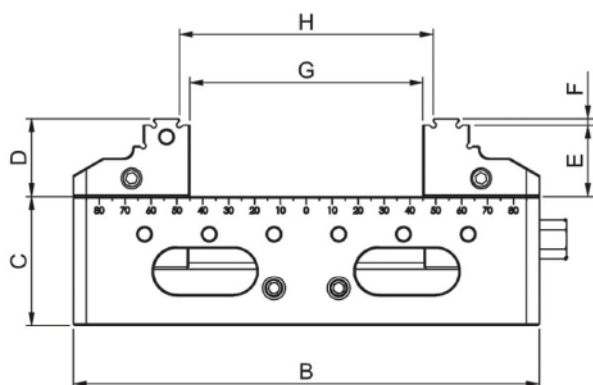
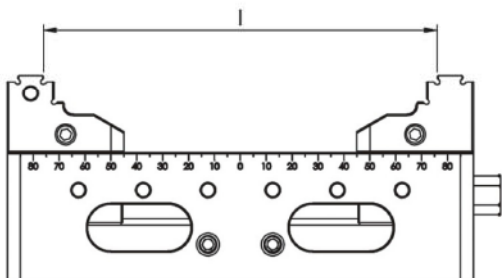
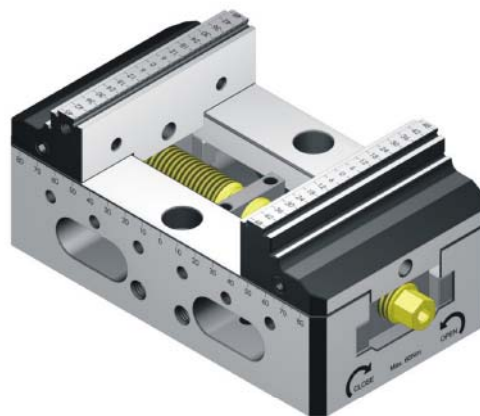

夾持曲線圖
(CLAMPING CURVE)

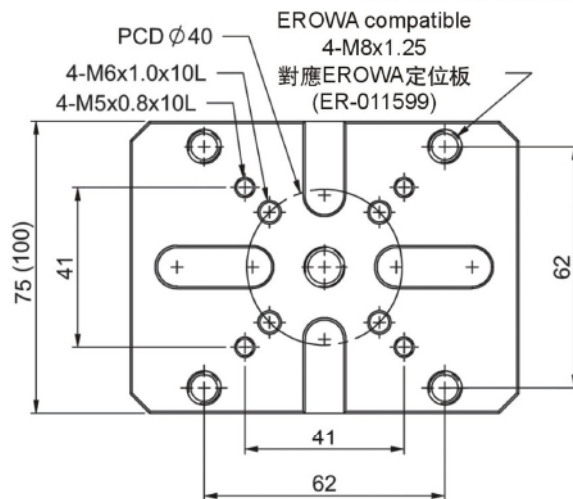
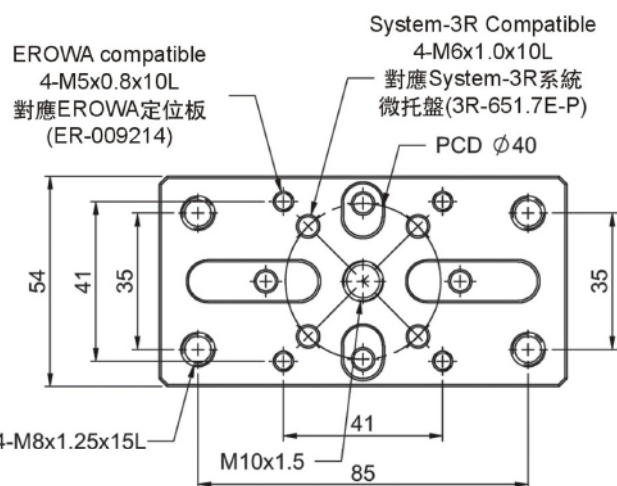
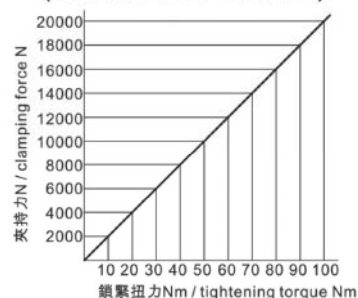

主體Body & 鉗口Jaws **M H** **A05**

Unit:mm

訂購編號 Order No.	型號 Model	A	B	C	D	E	F	G	H	I	重量 N.W.
64850-204V	PQV204V	54	105	50	20	18	2	0~35	8~43	42~77	2.3kg
64850-305V	PQV305V	75	130	50	21.5	19.5	2	0~50	8~58	52~102	3.8kg
64850-407V	PQV407V	100	180	50	30	27.5	2.5	0~90	8~98	62~152	6.8g

1. 適用於四軸、五軸、CNC分度盤、立臥式銑床。夾持工作物使之精密加工。

2. 虎鉗中心定位精度保持0.005mm。

3. 虎鉗本體材質使用合金鋼，可保持高耐磨性。

PQV

自定心虎鉗

Self-Centering Vise

PQV100WA
 Alloy Tool Steel **M** 合金工具鋼
H HRC50°~52°
特點

- ▶ 鉗口快速更換方向，旋轉180°增大夾持範圍。
- ▶ 根據夾持大小選用兩種鉗口，中間有防塵片防護。
- ▶ 鉗口重複夾持精度0.005mm。
- ▶ 可搭配52零點定位快換基座。

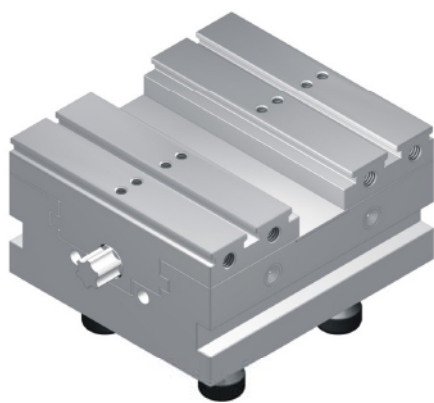
**Features**

- ▶ Quickly change the direction of the jaws and rotate 180° to increase the clamping range.
- ▶ Dust protective cover is included.
- ▶ Clamping repeating accuracy within 0.005mm.
- ▶ Compatible with zero-point 52mm

注：標配如P.A02頁所示大小鉗口各一組

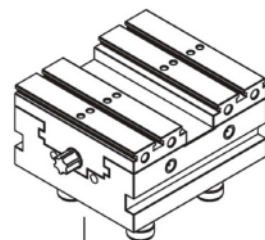
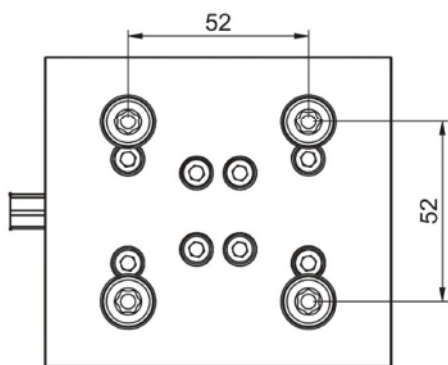
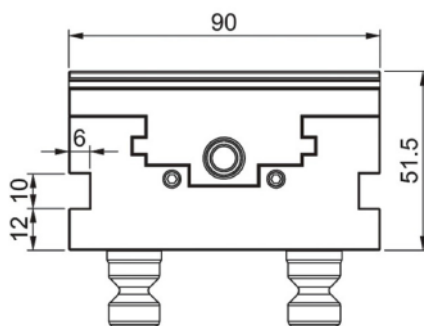
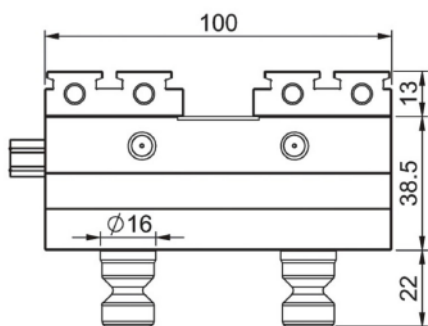
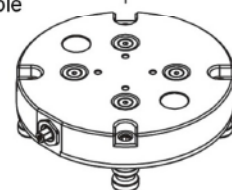
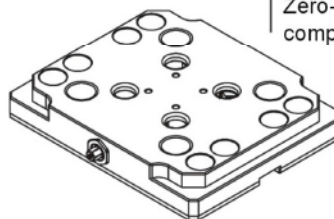
 Note: Standard two jaw sets are included ( **A02**)

 搭配各式快換基座
 Zero-point
 compatible

訂購編號 Order No.	型號 Model	描述 Description	重量 N.W.
64850-100WA	PQV100WA	可接零點定位快換系統 Zero-point point compatible	3.0kg

PQV

自定心虎鉗

Self-Centering Vice

PQV305 / 407

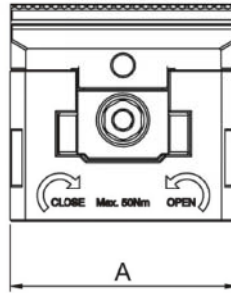
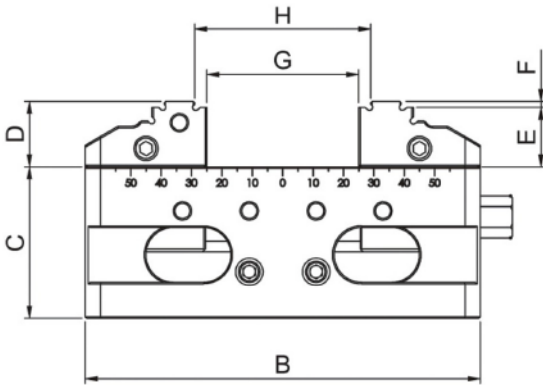
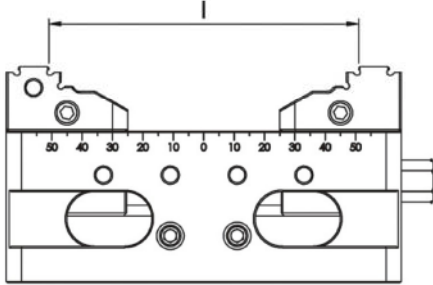

夾持曲線圖
(CLAMPING CURVE)

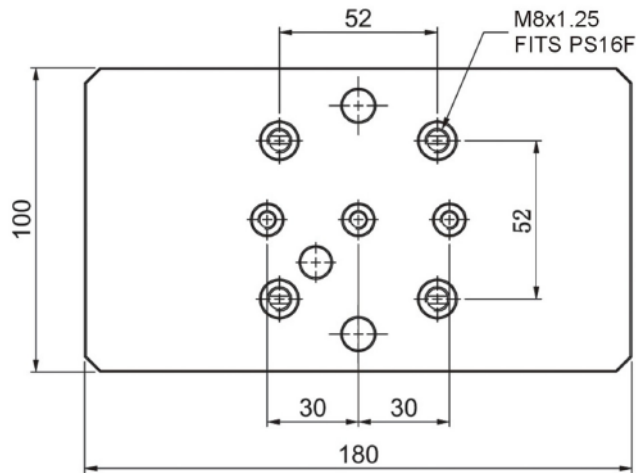
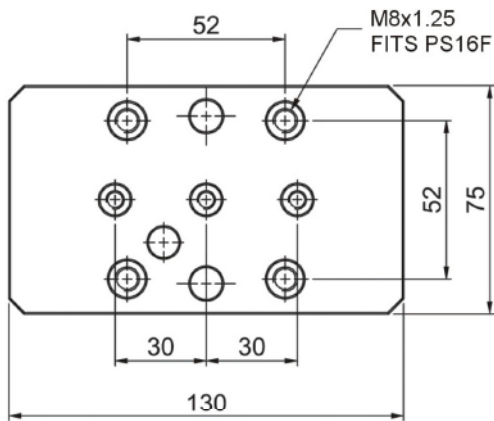
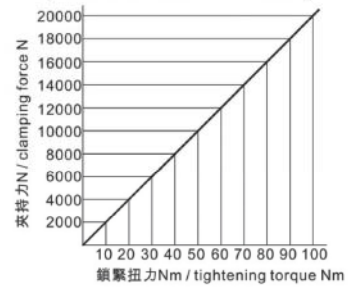

主體 **M** SKS3
Body **H** HRC50°

鉗口 **M** SCM440
Jaws **H** HRC53°~55°

Unit:mm

訂購編號 Order No.	型號 Model	A	B	C	D	E	F	G	H	I	重量 N.W.
64850-305	PQV305	75	130	50	21.5	19.5	2	0~50	8~58	52~102	3.8kg
64850-407	PQV407	100	180	50	30	27.5	2.5	0~90	8~98	62~152	6.8g

1. 適用於四軸、五軸、CNC分度盤、立臥式銑床。夾持工作物使之精密加工。

2. 虎鉗中心定位精度保持0.005mm。

3. 虎鉗本體材質使用合金鋼，可保持高耐磨性。

全系列優化 Optimisation in innovation

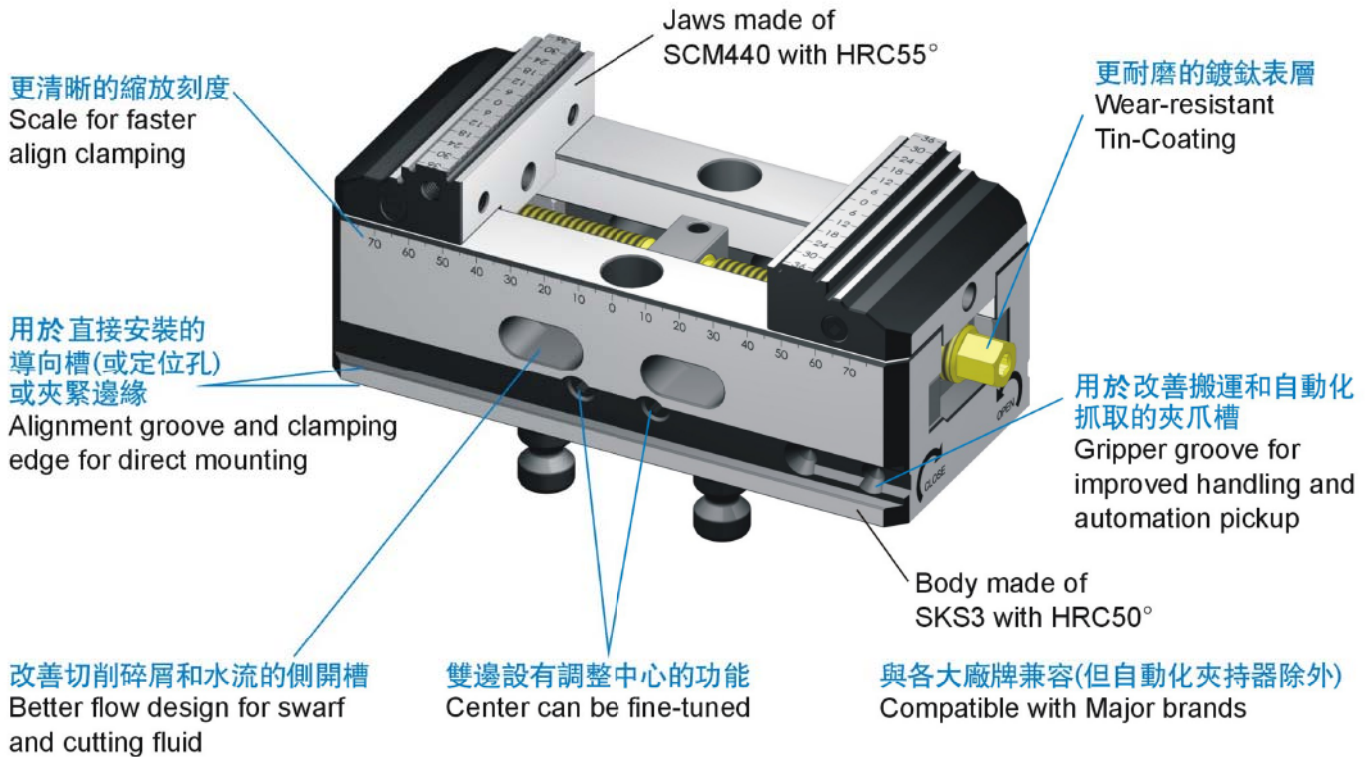

技術簡單，應用靈活

虎鉗的設計實用，可提供廣泛的應用，無論是立式三軸、第四軸或臥式及五軸加工機都有正確的解決方案。

在我們更新設計，優化使用上的方便性，以提供客戶使用上的簡易性。開發中零點定位螺柱採用96和52安裝，保持著和世界各國大廠牌兼容。並增加了四大特點：

1. 無螺絲快換式鉗口可在幾秒內180°反爪裝夾使夾持尺寸變大。
2. 單邊鉗口搖擺1.5°的專利設計，可隨著毛料工件不平行擺動貼合夾持，使夾持更穩定。
3. 提供了專利設計中心微調功能，可快速調整中心的位移。
4. 鉗口與帶動螺母使用角固式結構，可防止被夾持工件的上浮量。

SIMPLICITY AND FLEXIBILITY

PQV 5-axis centering vise is designed to be practical and can be utilised for a wide range of applications; 3-axis Vertical, 4-axis horizontal and 5-axis machining center all have the right solution.

In our updated design, optimization on the ease of use, with simplicity and flexibility.

Compatible with 52 & 96 system on major brands. Features are added below:

1. The screwless clamping jaws can be assembly 180° over in seconds for larger clamping range.
2. Patented swing 1.5° design on one side clamping jaw for better gripping when workpiece is non-parallel.
3. Patented fine-tuning center mechanism, easy to adjustify.
4. Special angle lock mechanism, preventing workpiece lifting when locked.

五軸自定心虎鉗

5-Axis Self-Centering Vice

極簡易的夾持組裝

Simplicity clamping assembly

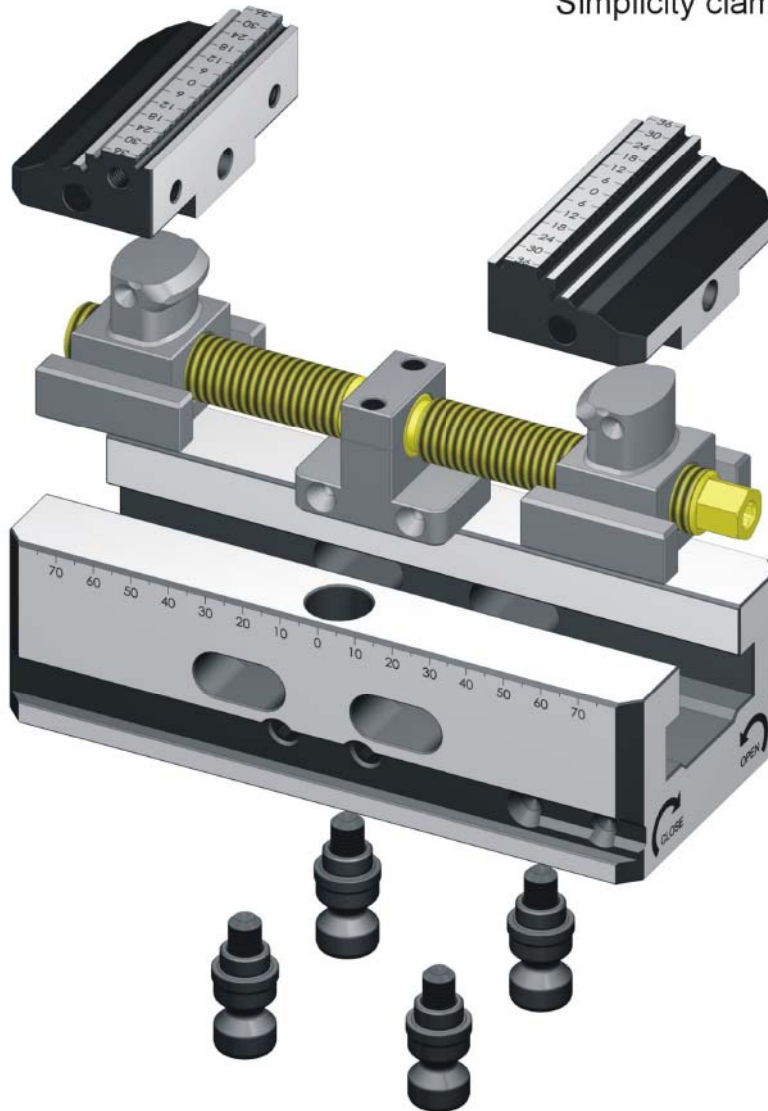

功能特點

簡單而又巧妙。基本上由8個單個零件組成，設計簡化為基本。形狀功能決定，以在實踐中產生最大效益。重點是可適用性，操作和靈活性。

虎鉗可用於各種夾緊任務，除了毛胚夾緊外還可與各種附件選項一起使用。

FUNCTIONAL CHARACTERISTICS

Simple and clever. Basically composed of 8 individual parts, the design is simplified to basic. Shape is determined by function to produce maximum benefit in practice. The emphasis is on serviceability, operation and flexibility.

The vise can be used for a variety of clamping tasks, in addition to blank clamping, and with a variety of accessory options.

PQV

五軸自定心虎鉗

5-Axis Self-Centering Vise

PQV77-54**鉗口寬度54mm****Jaw width 54mm****特點**

- ▶ 鉗口快速更換方向，旋轉180°增大夾持範圍。
- ▶ 夾爪鉗口和帶動螺母設有角固式接合，能減少夾持上浮量。
- ▶ 鉗口重複夾持精度0.005mm。
- ▶ 單邊夾持端的鉗口，可隨毛坯工件的不平行而擺動，增加毛坯素材夾緊力。

Features

- ▶ Quickly change the direction of the jaws and rotate 180° to increase the clamping range.
- ▶ Special angle lock mechanism, preventing workpiece lifting when locked.
- ▶ Clamping repeating accuracy within 0.005mm.
- ▶ Special swing 1.5° design on one side clamping jaw for better gripping when workpiece is non-parallel.

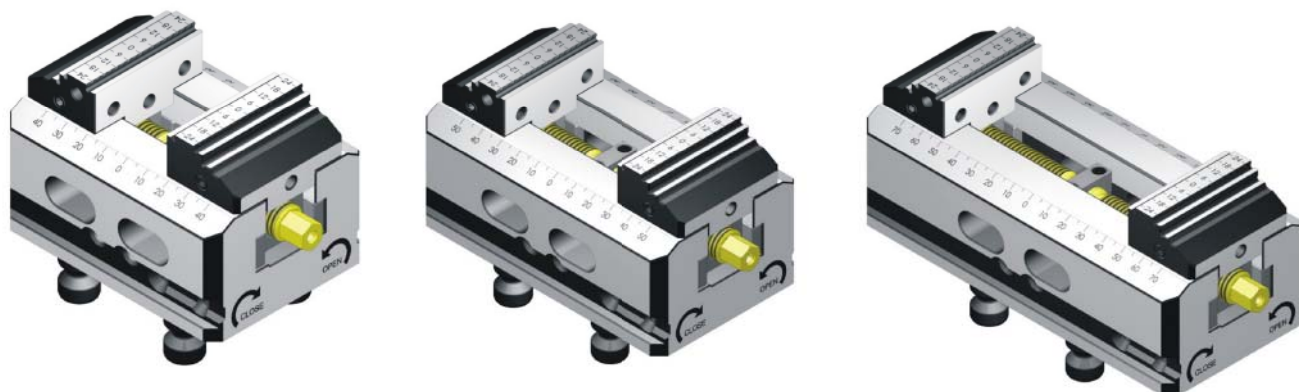

訂購編號 / Order No.	64880-54	64881-54	64882-54
型號 / Model	PQV354105	PQV354130	PQV354170
本體長度 / Body length	mm 105	130	170
夾持範圍 / Clamping range	mm 0~77	0~102	0~142
鉗口寬度 / Jaw width	mm	54	
零點系統 / Zero-point system		52	
零點螺栓 / Zero-point bolt		16	
擰緊力矩 / Tightening torque	Nm	60	
夾緊力 / Clamping force	kN	12	
中心定位精度 / Centring accuracy	mm	0.005	
重量 / Weight	kg 3.0	3.7	4.6

PQV

五軸自定心虎鉗

5-Axis Self-Centering Vice

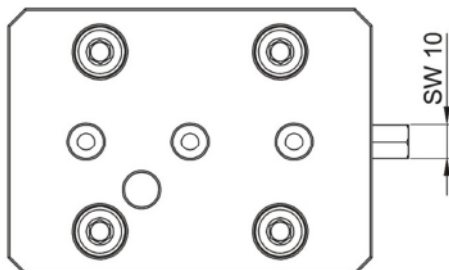
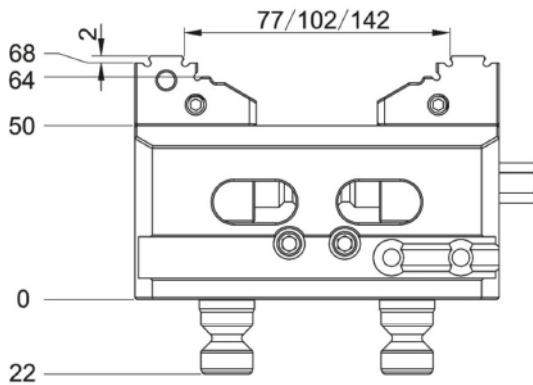
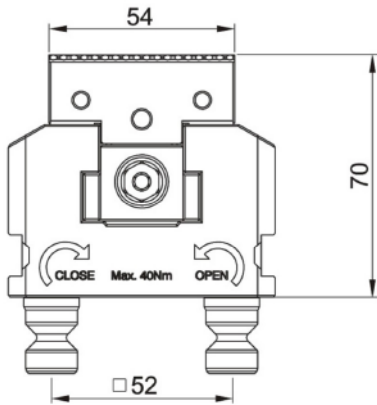
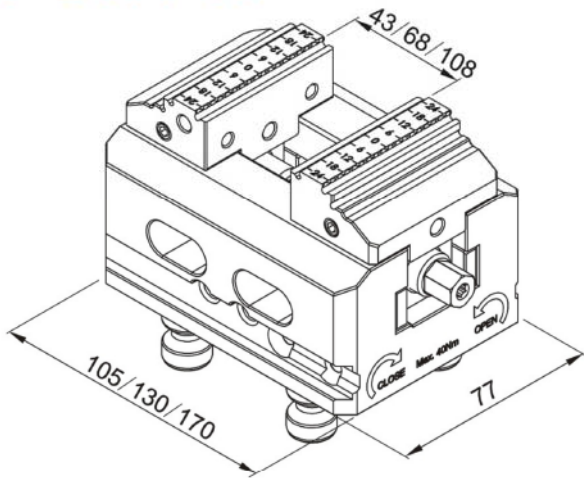
PQV77-54

- 左右鉗口
Jaw set



訂購編號 Order No.	64800-J54
----------------	------------------

鉗口寬度 / Jaw width mm	54
---------------------	----

適用於 / Compatible	PQV354105 / 130 / 170
------------------	-----------------------

- 左右螺母
Nut set

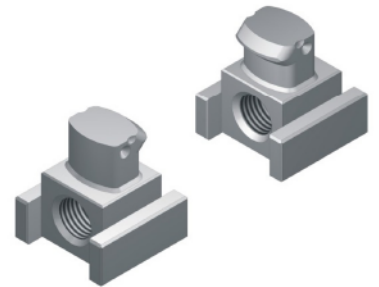

訂購編號 Order No.	64800-N14
----------------	------------------

螺母尺寸 / Screw Nut mm	M14
---------------------	-----

適用於 / Compatible	PQV354105 / 130 / 170
------------------	-----------------------

- 螺桿組件
Screw set

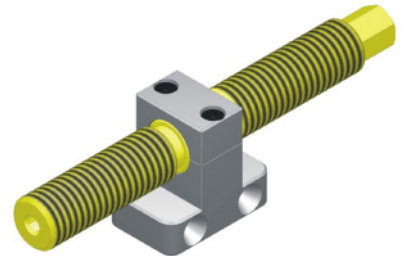

訂購編號 Order No.	64800-S14-105 / 130 170
----------------	--------------------------------

螺桿尺寸 / Screw size mm	M14x115 / 140 / 180
----------------------	---------------------

適用於 / Compatible	PQV354105 / 130 / 170
------------------	-----------------------

- 零點螺栓
Zero-point bolt set



訂購編號 Order No.	64942-16
----------------	-----------------

螺栓尺寸 / Bolt size mm	16
---------------------	----

適用於 / Compatible	PQV354105 / 130 / 170
------------------	-----------------------

PQV

五軸自定心虎鉗

5-Axis Self-Centering Vise

PQV77-75**鉗口寬度75mm****Jaw width 75mm****特點**

- ▶ 鉗口快速更換方向，旋轉180°增大夾持範圍。
- ▶ 夾爪鉗口和帶動螺母設有角固式接合，能減少夾持上浮量。
- ▶ 鉗口重複夾持精度0.005mm。
- ▶ 單邊夾持端的鉗口，可隨毛坯工件的不平行而擺動，增加毛坯素材夾緊力。

Features

- ▶ Quickly change the direction of the jaws and rotate 180° to increase the clamping range.
- ▶ Special angle lock mechanism, preventing workpiece lifting when locked.
- ▶ Clamping repeating accuracy within 0.005mm.
- ▶ Special swing 1.5° design on one side clamping jaw for better gripping when workpiece is non-parallel.

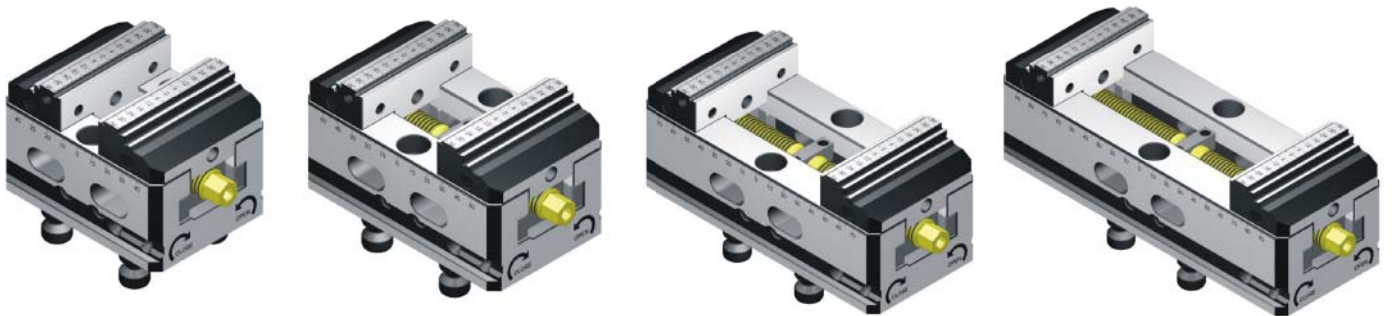

訂購編號 / Order No.		64883-75	64884-75	64885-75	64886-75
型號 / Model		PQV375105	PQV375130	PQV375170	PQV375210
本體長度 / Body length	mm	105	130	170	210
夾持範圍 / Clamping range	mm	0~77	0~102	0~142	0~182
鉗口寬度 / Jaw width	mm	75			
零點系統 / Zero-point system		52			
零點螺栓 / Zero-point bolt		16			
擰緊力矩 / Tightening torque	Nm	70			
夾緊力 / Clamping force	kN	14			
中心定位精度 / Centring accuracy	mm	0.005			
重量 / Weight	kg	3.3	3.9	4.8	5.7

PQV

五軸自定心虎鉗

5-Axis Self-Centering Vice

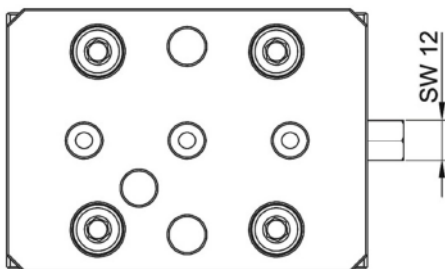
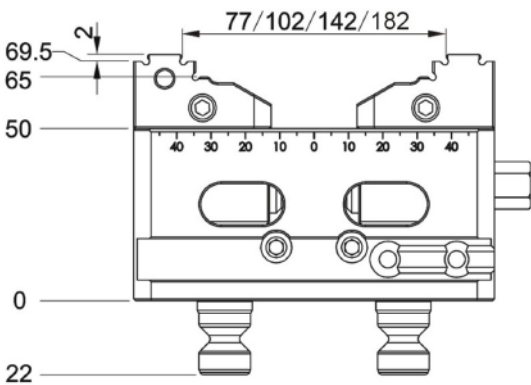
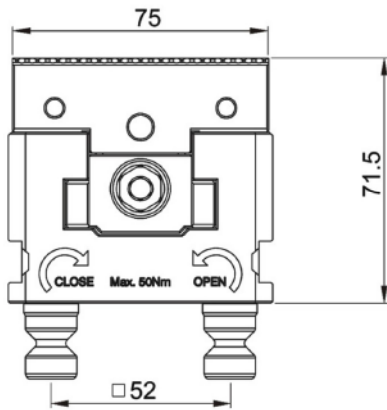
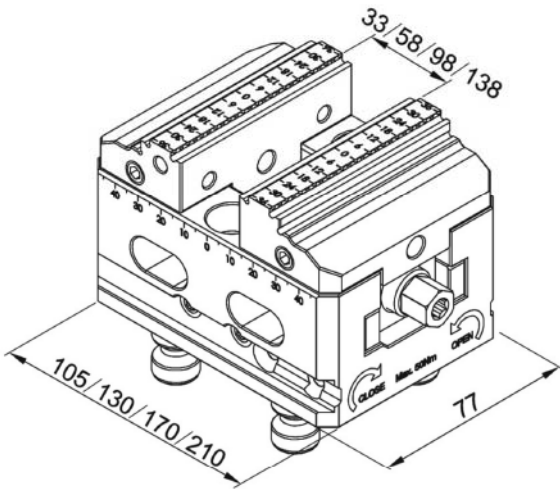
PQV77-75

- 左右鉗口
Jaw set



訂購編號 Order No.	64800-J75
----------------	------------------

鉗口寬度 / Jaw width	mm	75
適用於 / Compatible		PQV375105 / 130 / 170 / 210

- 左右螺母
Nut set

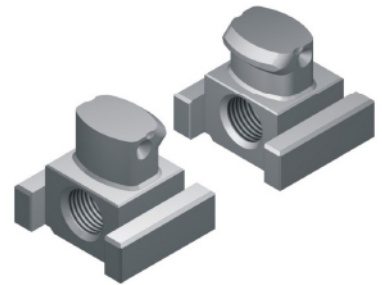

訂購編號 Order No.	64800-N16
----------------	------------------

螺母尺寸 / Screw Nut	mm	M16
適用於 / Compatible		PQV375105 / 130 / 170 / 210

- 螺桿組件
Screw set

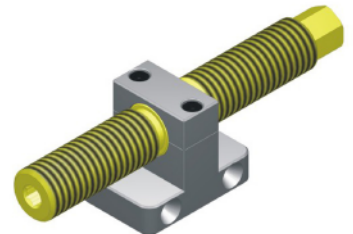

訂購編號 Order No.	64800-S16-105/130/170/210
----------------	----------------------------------

螺桿尺寸 / Screw size	mm	M16x115 / 140 / 180 / 220
適用於 / Compatible		PQV375105 / 130 / 170 / 210

- 零點螺栓
Zero-point bolt set



訂購編號 Order No.	64942-16
----------------	-----------------

螺栓尺寸 / Bolt size	mm	16
適用於 / Compatible		PQV375105 / 130 / 170 / 210

PQV125-75

鉗口寬度75mm

Jaw width 75mm

特點

- ▶ 鉗口快速更換方向，旋轉180°增大夾持範圍。
- ▶ 夾爪鉗口和帶動螺母設有角固式接合，能減少夾持上浮量。
- ▶ 鉗口重複夾持精度0.005mm。
- ▶ 單邊夾持端的鉗口，可隨毛胚工件的不平行而擺動，增加毛胚素材夾緊力。

Features

- ▶ Quickly change the direction of the jaws and rotate 180° to increase the clamping range.
- ▶ Special angle lock mechanism, preventing workpiece lifting when locked.
- ▶ Clamping repeating accuracy within 0.005mm.
- ▶ Special swing 1.5° design on one side clamping jaw for better gripping when workpiece is non-parallel.

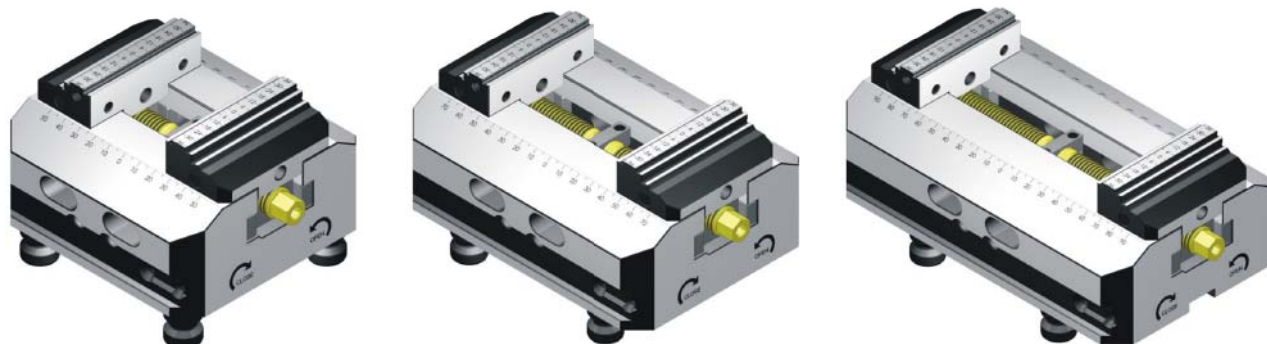

訂購編號 / Order No.	64887-75	64888-75	64889-75
型號 / Model	PQV575130	PQV575170	PQV575210
本體長度 / Body length	mm 130	170	210
夾持範圍 / Clamping range	mm 0~102	0~142	0~182
鉗口寬度 / Jaw width	mm	75	
零點系統 / Zero-point system		96	
零點螺栓 / Zero-point bolt		20	
擰緊力矩 / Tightening torque	Nm	70	
夾緊力 / Clamping force	kN	14	
中心定位精度 / Centring accuracy	mm	0.005	
重量 / Weight	kg 6.7	8.6	10.4

PQV

五軸自定心虎鉗

5-Axis Self-Centering Vice

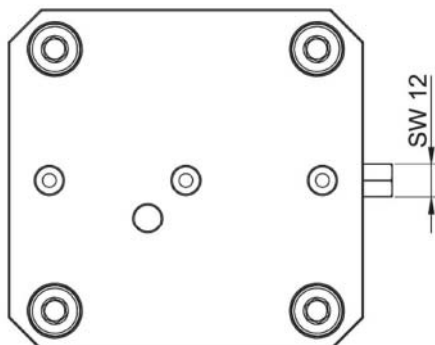
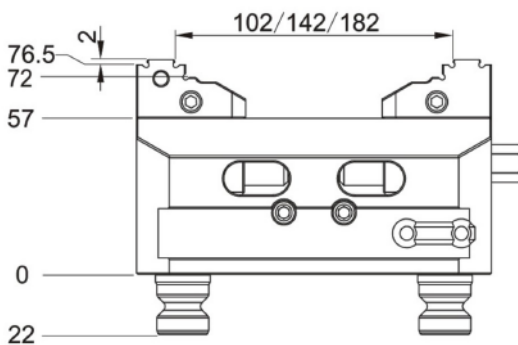
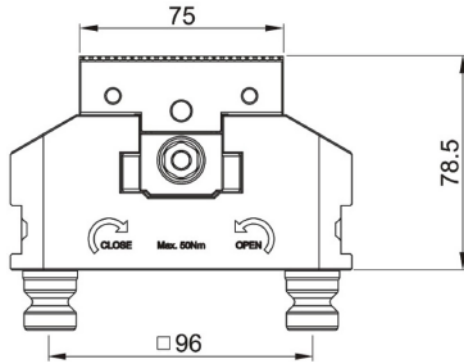
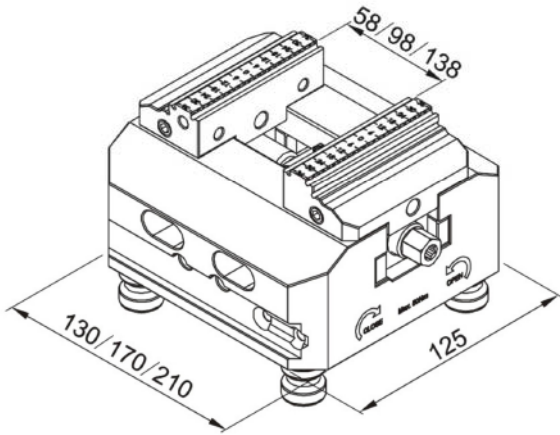
PQV125-75

- 左右鉗口
Jaw set



訂購編號 Order No.	64800-J75
鉗口寬度 / Jaw width mm	75
適用於 / Compatible	PQV575130 / 170 / 210

- 左右螺母
Nut set

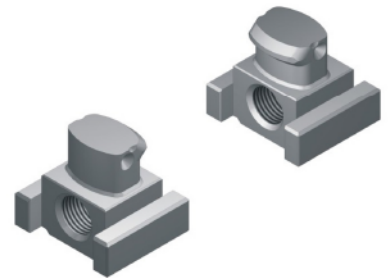

訂購編號 Order No.	64800-N16
螺母尺寸 / Screw Nut mm	M16
適用於 / Compatible	PQV575130 / 170 / 210

- 螺桿組件
Screw set

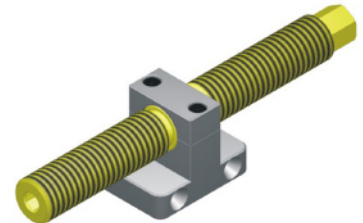

訂購編號 Order No.	64800-S16-130/170/210
螺桿尺寸 / Screw size mm	M16x140 / 180 / 220
適用於 / Compatible	PQV575130 / 170 / 210

- 零點螺栓
Zero-point bolt set



訂購編號 Order No.	64942-20
螺栓尺寸 / Bolt size mm	20
適用於 / Compatible	PQV575130 / 170 / 210

PQV

五軸自定心虎鉗

5-Axis Self-Centering Vise

PQV125-125

鉗口寬度125mm

Jaw width 125mm

特點

- ▶ 鉗口快速更換方向，旋轉180°增大夾持範圍。
- ▶ 夾爪鉗口和帶動螺母設有角固式接合，能減少夾持上浮量。
- ▶ 鉗口重複夾持精度0.005mm。
- ▶ 單邊夾持端的鉗口，可隨毛胚工件的不平行而擺動，增加毛胚素材夾緊力。

Features

- ▶ Quickly change the direction of the jaws and rotate 180° to increase the clamping range.
- ▶ Special angle lock mechanism, preventing workpiece lifting when locked.
- ▶ Clamping repeating accuracy within 0.005mm.
- ▶ Special swing 1.5° design on one side clamping jaw for better gripping when workpiece is non-parallel.

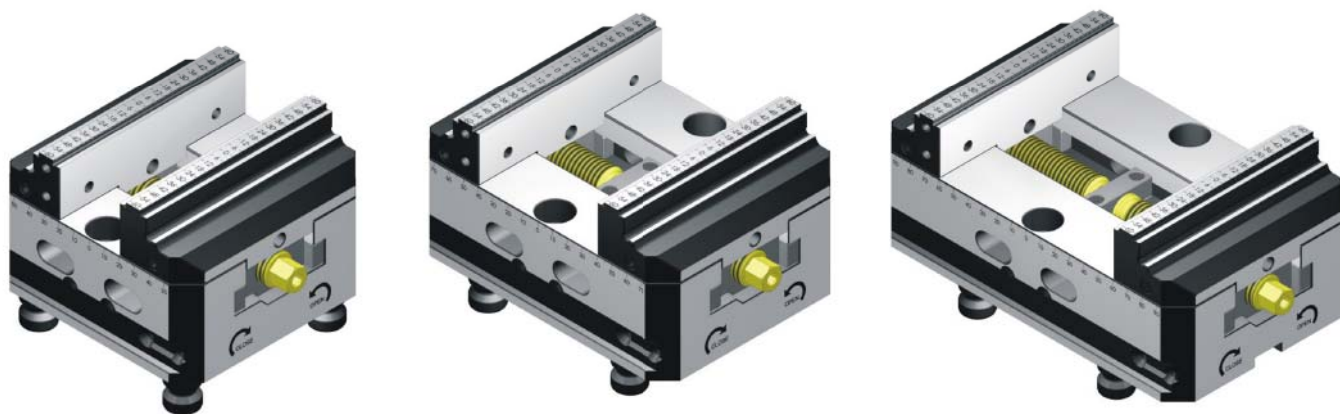

訂購編號 / Order No.		64890-125	64891-125	64892-125
型號 / Model		PQV125130	PQV125170	PQV125210
本體長度 / Body length	mm	130	170	210
夾持範圍 / Clamping range	mm	0~102	0~142	0~182
鉗口寬度 / Jaw width	mm	125		
零點系統 / Zero-point system		96		
零點螺栓 / Zero-point bolt		20		
擰緊力矩 / Tightening torque	Nm	100		
夾緊力 / Clamping force	kN	16		
中心定位精度 / Centring accuracy	mm	0.005		
重量 / Weight	kg	8.0	9.8	11.5

PQV

五軸自定心虎鉗

5-Axis Self-Centering Vice

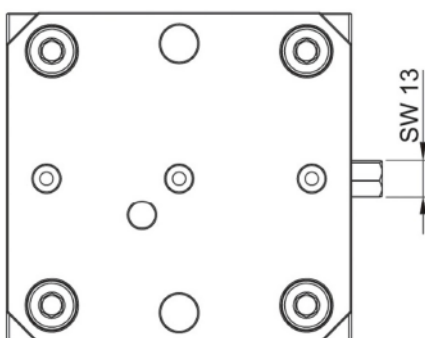
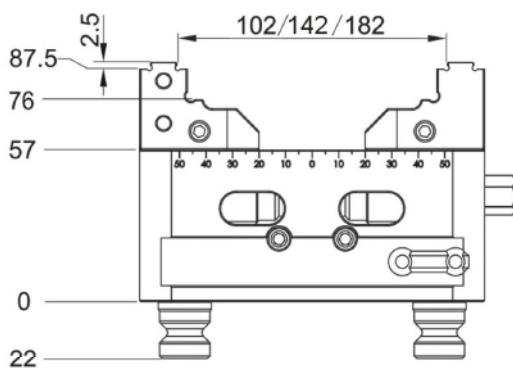
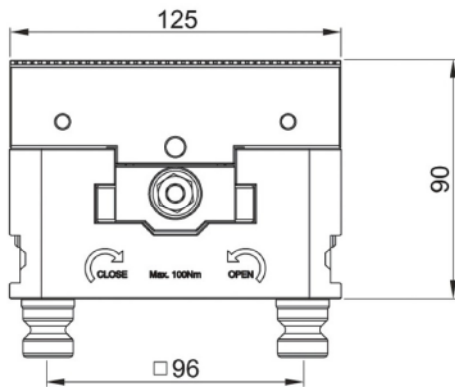
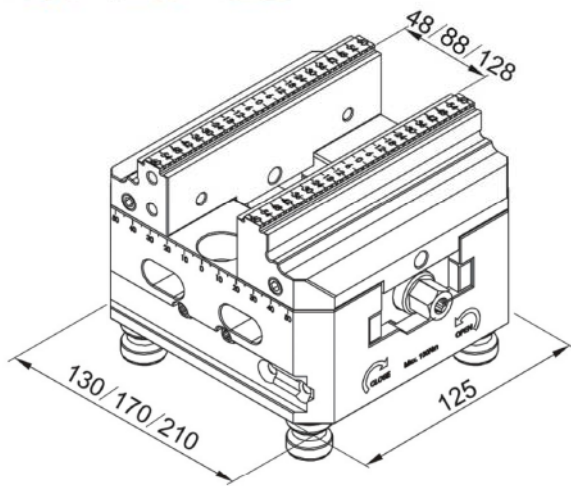
PQV125-125

- 左右鉗口
Jaw set



訂購編號 Order No.	64800-J125
----------------	-------------------

鉗口寬度 / Jaw width mm	125
適用於 / Compatible	PQV125130 / 170 / 210

- 左右螺母
Nut set

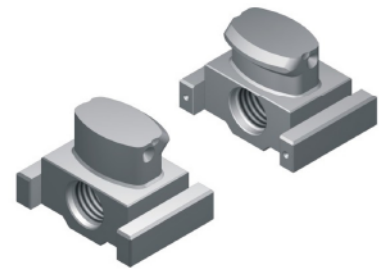

訂購編號 Order No.	64800-N19
----------------	------------------

螺母尺寸 / Screw Nut mm	M19
適用於 / Compatible	PQV125130 / 170 / 210

- 螺桿組件
Screw set

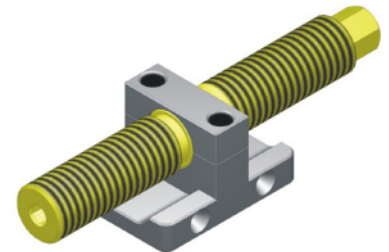

訂購編號 Order No.	64800-S19-130/170/210
----------------	------------------------------

螺桿尺寸 / Screw size mm	M19x140 / 181 / 221
適用於 / Compatible	PQV125130 / 170 / 210

- 零點螺栓
Zero-point bolt set



訂購編號 Order No.	64942-20
----------------	-----------------

螺栓尺寸 / Bolt size mm	20
適用於 / Compatible	PQV125130 / 170 / 210

PQV125-125

鉗口寬度125mm

Jaw width 125mm

特點

- ▶ 鉗口快速更換方向，旋轉180°增大夾持範圍。
- ▶ 夾爪鉗口和帶動螺母設有角固式接合，能減少夾持上浮量。
- ▶ 鉗口重複夾持精度0.005mm。
- ▶ 單邊夾持端的鉗口，可隨毛坯工件的不平行而擺動，增加毛坯素材夾緊力。

Features

- ▶ Quickly change the direction of the jaws and rotate 180° to increase the clamping range.
- ▶ Special angle lock mechanism, preventing workpiece lifting when locked.
- ▶ Clamping repeating accuracy within 0.005mm.
- ▶ Special swing 1.5° design on one side clamping jaw for better gripping when workpiece is non-parallel.



訂購編號 / Order No.		64893-125	64894-125	64895-125
型號 / Model		PQV125260	PQV125310	PQV125360
本體長度 / Body length	mm	260	310	360
夾持範圍 / Clamping range	mm	0~232	0~282	0~332
鉗口寬度 / Jaw width	mm	125		
零點系統 / Zero-point system		96		
零點螺栓 / Zero-point bolt		20		
擰緊力矩 / Tightening torque	Nm	100		
夾緊力 / Clamping force	kN	16		
中心定位精度 / Centring accuracy	mm	0.005		
重量 / Weight	kg	13.8	16.1	18.4

PQV

五軸自定心虎鉗

5-Axis Self-Centering Vice

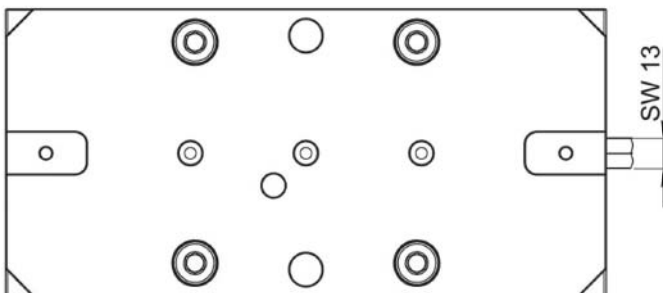
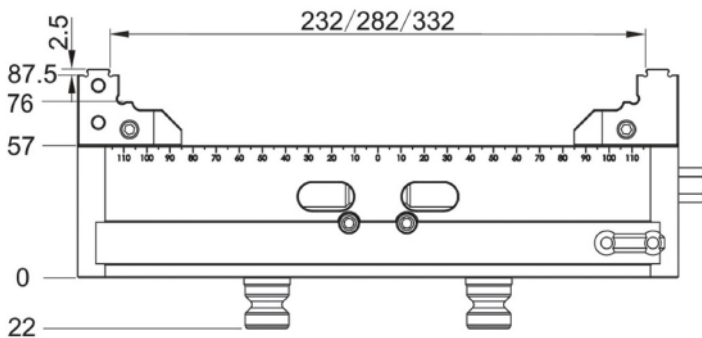
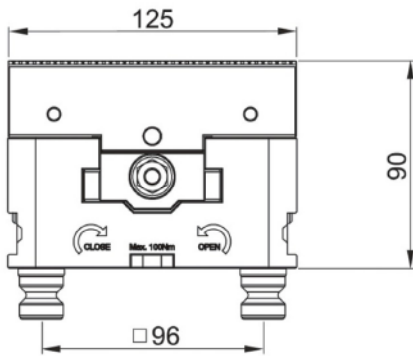
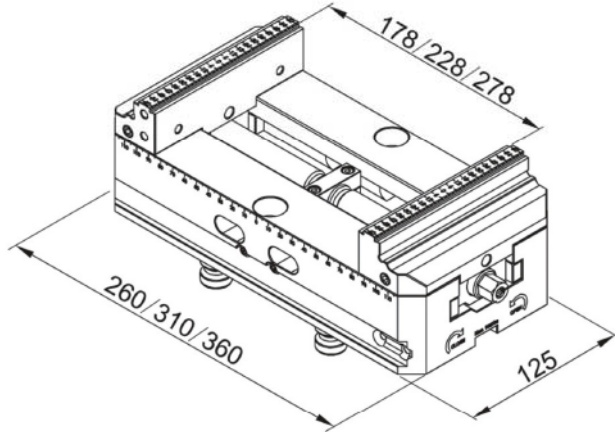
PQV125-125

- 左右鉗口
Jaw set



訂購編號 Order No.	64800-J125
----------------	-------------------

鉗口寬度 / Jaw width mm	125
適用於 / Compatible	PQV125260 / 310 / 360

- 左右螺母
Nut set

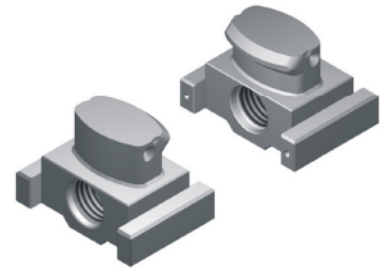

訂購編號 Order No.	64800-N19
----------------	------------------

螺母尺寸 / Screw Nut mm	M19
適用於 / Compatible	PQV125260 / 310 / 360

- 螺桿組件
Screw set

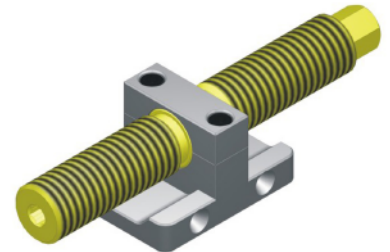

訂購編號 Order No.	64800-S19-260/310/360
----------------	------------------------------

螺桿尺寸 / Screw size mm	M19x271 / 321 / 371
適用於 / Compatible	PQV125260 / 310 / 360

- 零點螺栓
Zero-point bolt set



訂購編號 Order No.	64942-20
----------------	-----------------

螺栓尺寸 / Bolt size mm	20
適用於 / Compatible	PQV125260 / 310 / 360

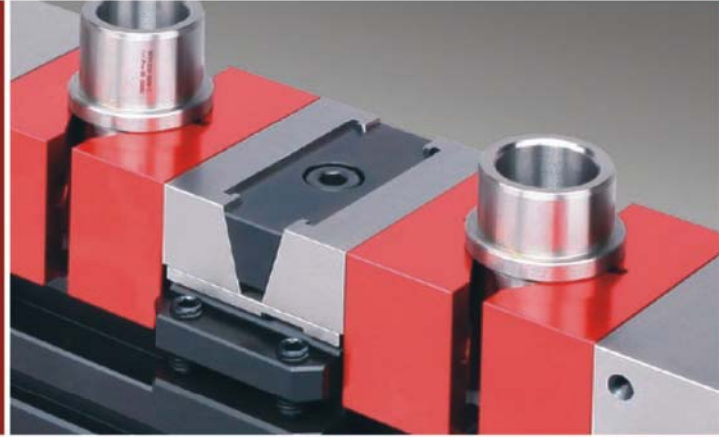

Gin Tech reserves the right to change the specification without prior notice

**精展精密科技股份有限公司(總公司)
GIN TECH PRECISION CO., LTD.**

238001台灣新北市樹林區保安街一段341巷7號
Address: No 7, Lane 341, Sec. 1, Bau An Street, Shu lin Dist.,
New Taipei City, 238001, Taiwan

TEL: 886-2-2681-8596 (Rep.)
FAX: 886-2-2681-8516

Email: Sales@ginchan.com.tw
Web: www.gin-chan.com

**東莞美商精展機械五金有限公司
東莞市精展機械五金有限公司
GIN CHAN MACHINERY & HARDWARE CO., LTD.(DONGGUAN)**

廣東省東莞市大朗鎮石廈村金沙崗二路27號
Address: No 27, Jinshagang 2nd Road, Shixia Village,
Dalang Town, Dongguan, Guandong, P.R. China

TEL : 86-769-8318-5858 (Rep.)
FAX: 86-769-8318-5838/8313-5003

Email: Sales@ginchan.com.cn
Web: www.ginchan.com.cn



YouTube



微信扫一扫